

DTC	P0130/21	Oxygen Sensor Circuit Malfunction (Bank 1 Sensor 1)
------------	-----------------	--

DTC	P0150/58	Oxygen Sensor Circuit Malfunction (Bank 2 Sensor 1)
------------	-----------------	--

CIRCUIT DESCRIPTION

To obtain a high purification rate for the CO, HC and NOx components of the exhaust gas, a three-way catalytic converter is used, but for the most efficient use of the three-way catalytic converter, the air-fuel ratio must be precisely controlled so that it is always close to the stoichiometric air-fuel ratio.

The oxygen sensor has the characteristic whereby its output voltage changes suddenly in the vicinity of the stoichiometric air-fuel ratio. This characteristic is used to detect the oxygen concentration in the exhaust gas and provide feedback to the computer for control of the air-fuel ratio.

When the air-fuel ratio becomes LEAN, the oxygen concentration in the exhaust increases and the oxygen sensor informs the engine ECU of the LEAN condition (small electromotive force: 0 V).

When the air-fuel ratio is RICHER than the stoichiometric air-fuel ratio the oxygen concentration in the exhaust gas is reduced and the oxygen sensor informs the engine ECU of the RICH condition (large electromotive force: 1 V). The engine ECU judges by the electromotive force from the oxygen sensor whether the air-fuel ratio is RICH or LEAN and controls the injection time accordingly. However, if malfunction of the oxygen sensor causes output of abnormal electromotive force, the engine ECU is unable to perform accurate air-fuel ratio control.

The oxygen sensors include a heater which heats the Zirconia element. The heater is controlled by the engine ECU. When the intake air volume is low (the temperature of the exhaust gas is low) current flows to the heater to heat the sensor for accurate oxygen concentration detection.

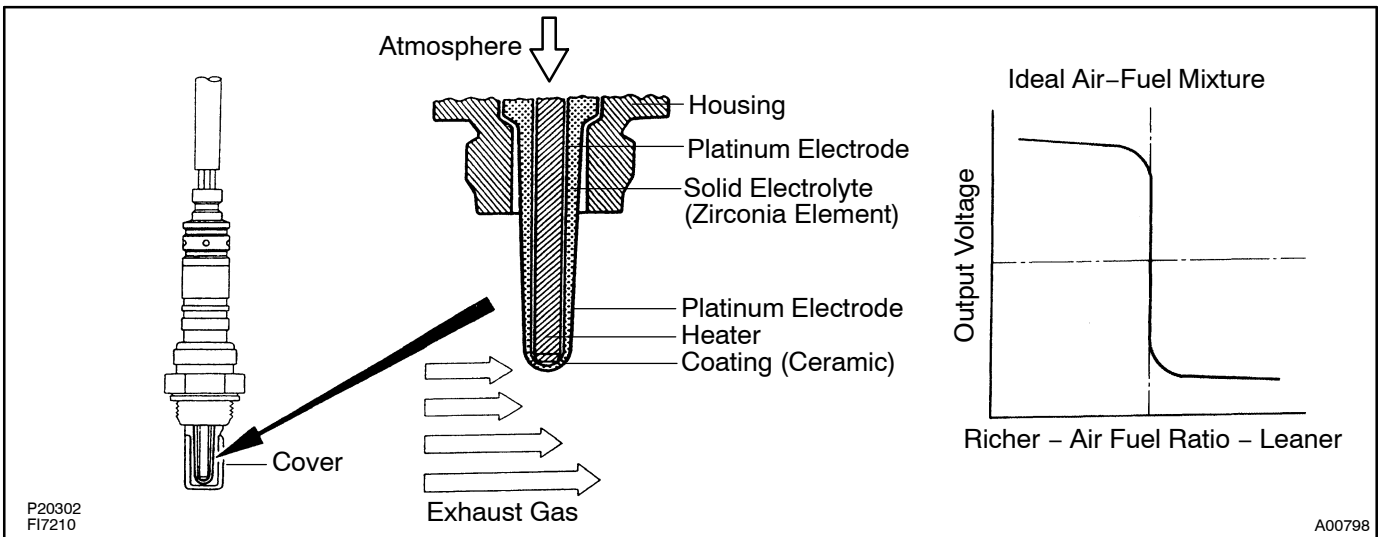

P20302
F17210

A00798

DTC No.	DTC Detecting Condition	Trouble Area
P0130/21 P0150/28	Voltage output of heated oxygen sensor remains at 0.4 V or more, or 0.55 V or less, at three times during idling after engine is warmed up (2 trip detection logic)	<ul style="list-style-type: none"> • Oxygen sensor • Fuel trim malfunction

HINT:

Bank 1 refers to bank that includes cylinder No.1.

Bank 2 refers to bank that does not include cylinder No.1.

Sensor 1 refers to the sensor closer to the engine body.

The oxygen sensor's output voltage and the short-term fuel trim value can be read using the hand-held tester.

WIRING DIAGRAM

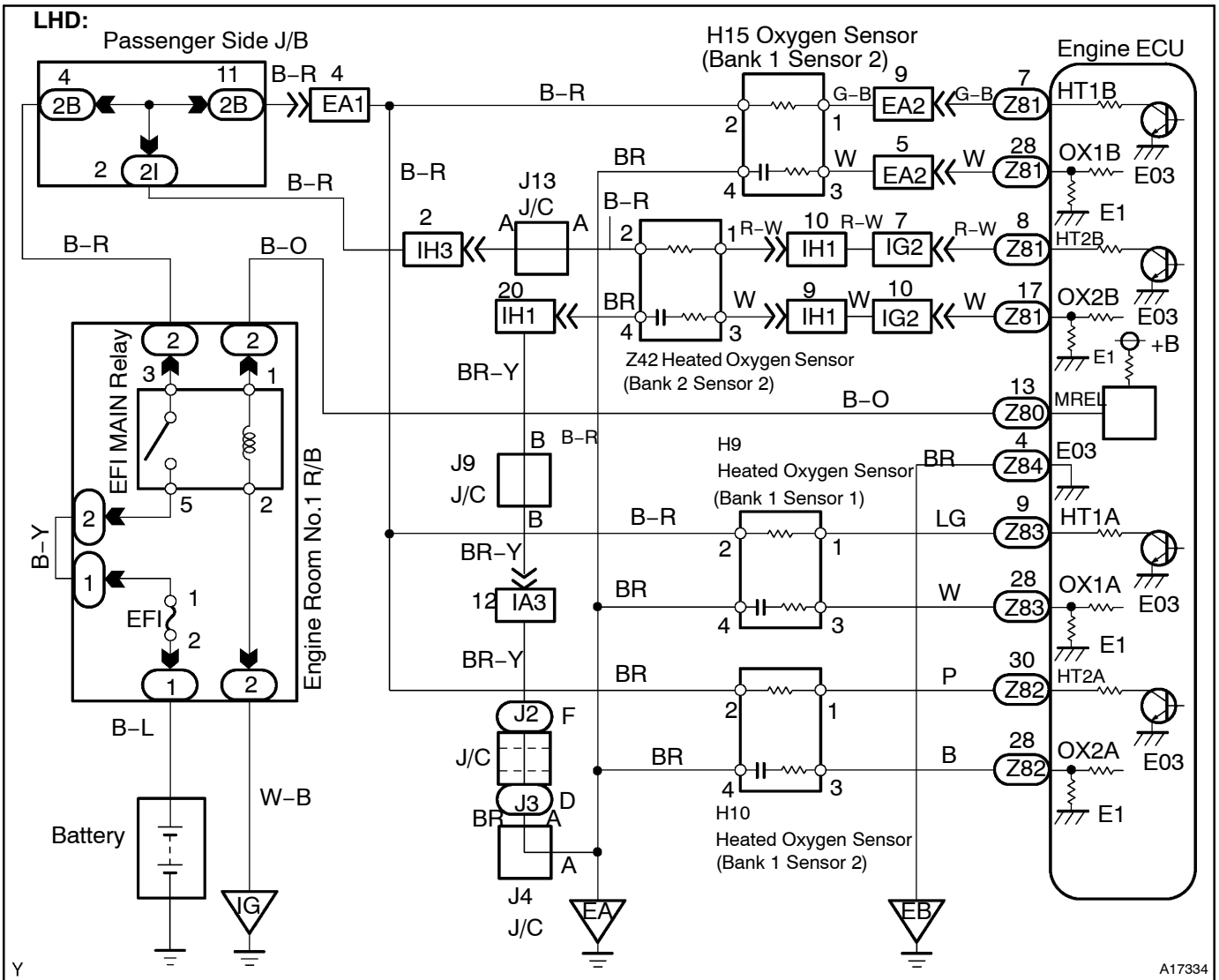

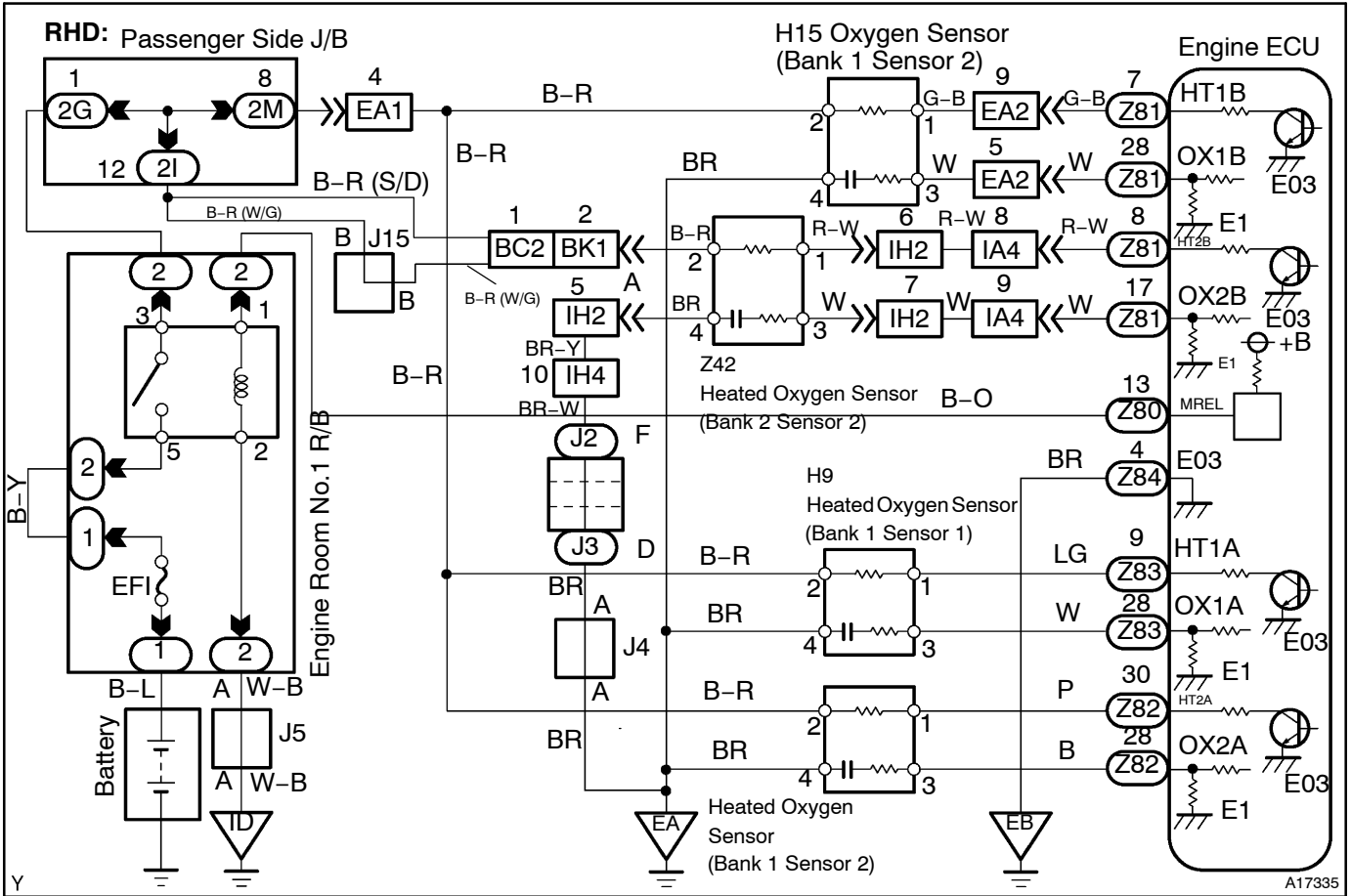

CONFIRMATION DRIVING PATTERN

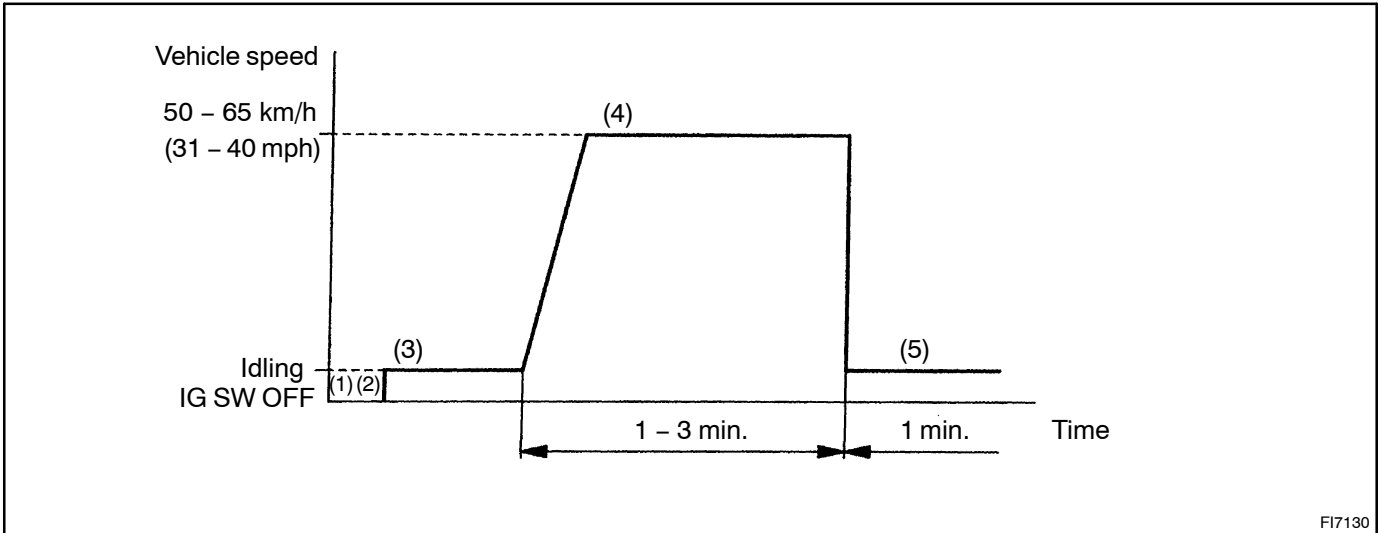

- (1) Connect the hand-held tester to the DLC3.
- (2) Switch the hand-held tester from normal mode to check (test) mode (See page DI-4)
- (3) Start the engine and warm it up with all accessory switches OFF.
- (4) Drive the vehicle at 50 - 65 km/h (31 - 40 mph) for 1 - 3 min. to warm up the heated oxygen sensor.
- (5) Let the engine idle for 1 min.
- (6) Perform steps (3) to (5) three times.

HINT:

If a malfunction exists, the CHECK ENG will be indicated on the multi information display during step (6).

NOTICE:

If the conditions in this test are not strictly followed, detection of the malfunction will not be possible. If you do not have a hand-held tester, turn the ignition switch OFF after performing steps (3) to (6), then perform steps (3) to (6) again.

INSPECTION PROCEDURE**When using hand-held tester****HINT:**

Read freeze frame data using hand-held tester. Because freeze frame records the engine conditions when the malfunction is detected, when troubleshooting it is useful for determining whether the vehicle was running or stopped, the engine warmed up or not, the air-fuel ratio lean or rich, etc. at the time of the malfunction.

- | | |
|----------|---|
| 1 | Check for open and short in harness and connector between engine ECU and oxygen sensor (See page IN-34). |
|----------|---|

NG

Repair or replace harness or connector.

OK

- | | |
|----------|--------------------------------------|
| 2 | Check for oxygen sensor data. |
|----------|--------------------------------------|

PREPARATION:

- (a) Connect the hand-held tester to the DLC3.
- (b) Warm up the engine to normal operating temp.

CHECK:

Read the oxygen sensor output voltage and short-term fuel trim.

RESULT:

Pattern	Heated oxygen sensor output voltage	Short-term fuel trim
1	Lean condition (Changes at 0.55 V or less)	Changes at about +20 %
2	Rich condition (Changes at 0.4 V or more)	Changes at about -20 %
3	Except 1 and 2	

1, 2

Check fuel trim system (See page DI-71).

3

3 Check output voltage of oxygen sensor during idling.

PREPARATION:

Warm up the oxygen sensor with the engine at 2,500 rpm for approx. 90 sec.

CHECK:

Use the hand-held tester read the output voltage of the oxygen sensor during idling.

OK:

Oxygen sensor output voltage:

Alternates repeatedly between less than 0.4 V and more than 0.55 V (See the following table).

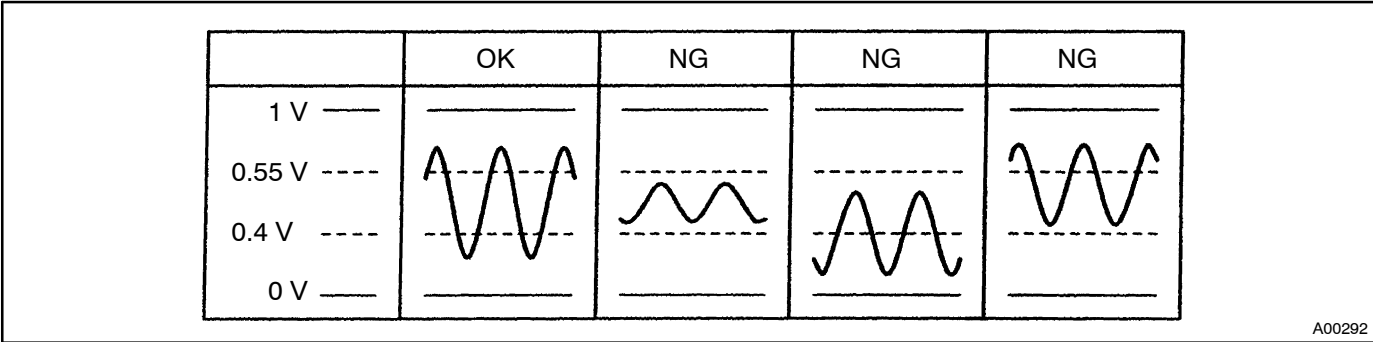

OK
Perform confirmation driving pattern.

NG

Replace oxygen sensor.

When not using hand-held tester

1 Are there any other codes (besides code 21 and 28) being output?

YES

Go to relevant diagnostic trouble code chart
(See [page DI-17](#)).

NO

Replace heated oxygen sensor.

Ox signal wave form

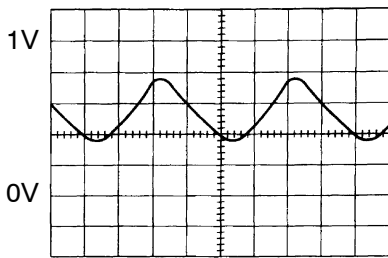
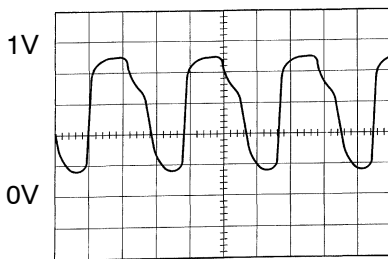

FI6514
FI6515

A00539

Reference: INSPECTION USING OSCILLOSCOPE

With the engine racing (4,000 rpm) measure waveform between terminals OXL1 and E1 of engine ECU.

HINT:

- The correct waveform is as shown oscillating between approx. 0.1 V and 0.9 V.
- If the oxygen sensor has deteriorated, the amplitude of the voltage will be reduced as shown on the left.