

<b>DTC</b>	<b>P1125/89*</b>	<b>Throttle Control Motor Circuit Malfunction</b>
------------	------------------	---

\*: ETCS trouble code No. is 21.

## CIRCUIT DESCRIPTION

Throttle motor is operated by the engine ECU and it opens and closes the throttle valve.

The opening angle of the throttle valve is detected by the throttle position sensor which is mounted on the throttle body and it provides feedback to the engine ECU to control the throttle motor in order to the throttle valve opening angle properly in response to driving condition.

If this DTC is stored, the engine ECU shuts down the power for the throttle motor and the magnetic clutch, and the throttle valve is fully closed by the return spring.

However, the opening angle of the throttle valve can be controlled by the accelerator pedal through the throttle cable.

DTC No.	DTC Detecting Condition	Trouble Area
P1125/89*	Condition (a) and (b) continues for 0.5 seconds: (a) Throttle control motor output duty $\geq 80\%$ (b) Throttle control motor current $< 0.5\text{ A}$	<ul style="list-style-type: none"> <li>• Open or short in throttle control motor circuit</li> <li>• Throttle control motor</li> <li>• Engine ECU</li> </ul>
	Throttle control motor current $\geq 16\text{ A}$	
	Under condition continue for 0.6 seconds: Throttle control motor current $\geq 7\text{ A}$	

## WIRING DIAGRAM

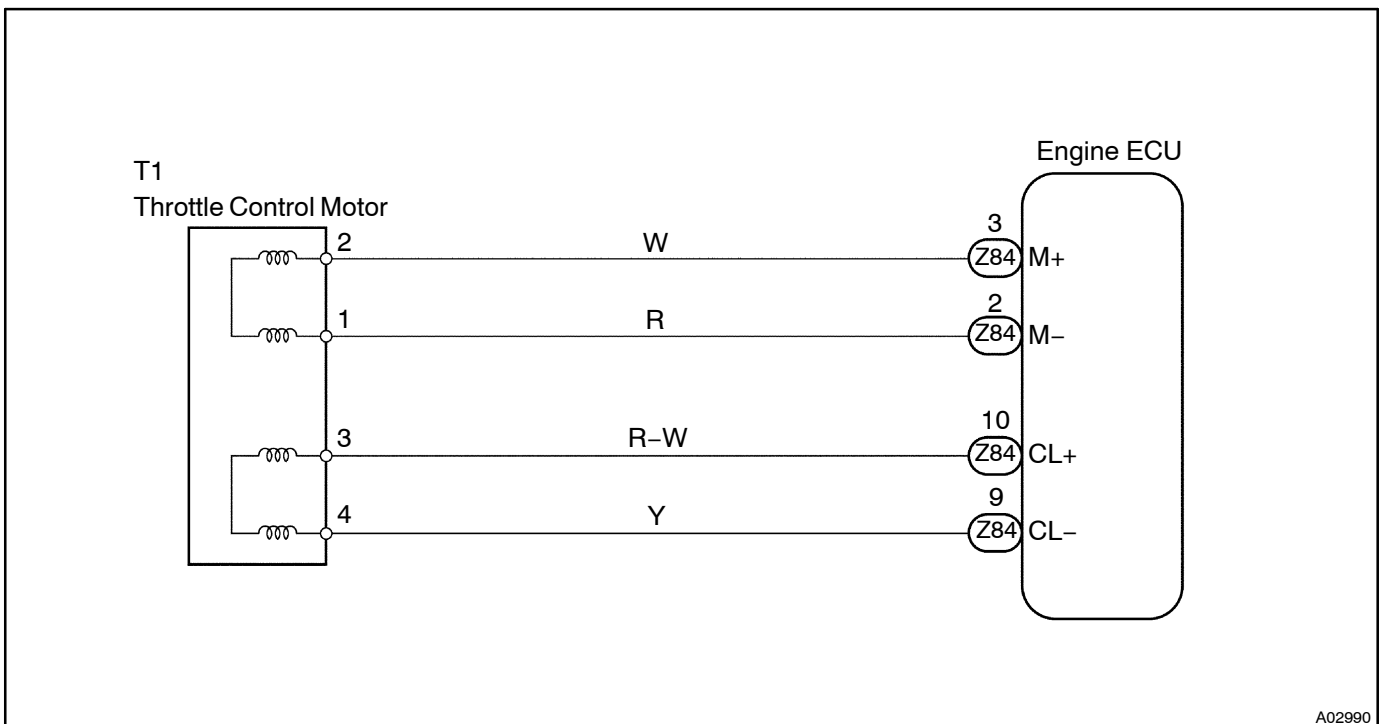

A02990

## INSPECTION PROCEDURE

### HINT:

Read freeze frame data using hand-held tester. Because freeze frame records the engine conditions when the malfunction is detected, when troubleshooting it is useful for determining whether the vehicle was running or stopped, the engine warmed up or not, the air-fuel ratio lean or rich, etc. at the time of the malfunction.

### 1 Check throttle control motor circuit.

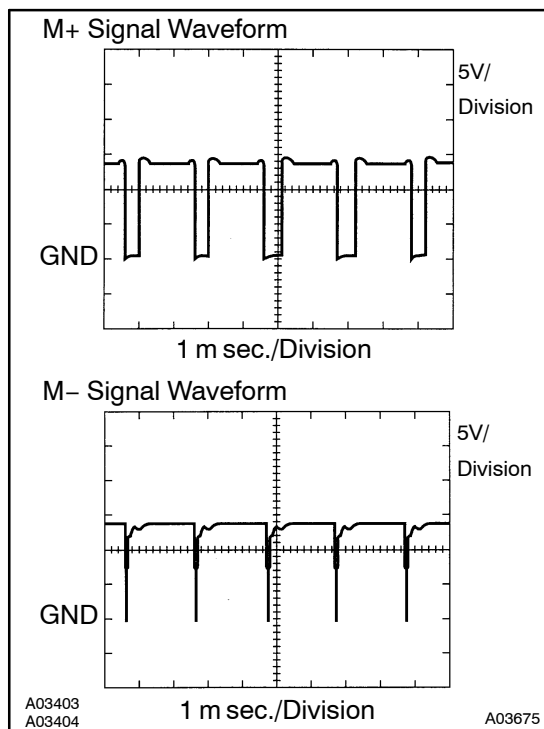

### PREPARATION:

- Connect the oscilloscope between terminals M+ or M- and E1 of the engine ECU.
- Start the engine.

### CHECK:

Check the waveform between terminals M+ or M- and E1 of the engine ECU when engine is idling.

### OK:

**The correct waveforms are as shown.**

### HINT:

The waveform frequency varies depending on the throttle opening.

OK

Check and replace engine ECU (See page IN-34).

NG

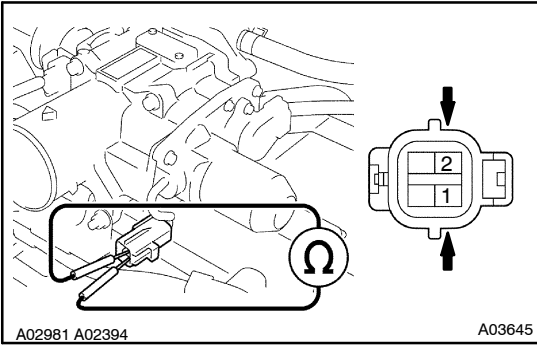
**2 Check throttle control motor.****PREPARATION:**

Disconnect the throttle control motor and magnetic clutch connector.

**CHECK:**

Measure resistance between terminals 1 and 2 of the throttle control motor and magnetic clutch.

**OK:**

Resistance: 0.3 - 100 Ω at 20 °C (68 °F)

**NG**

Replace throttle control motor (See page FI-37).

**OK****3 Check for open and short in harness and connector between throttle control motor and engine ECU (See page IN-34).****NG**

Repair or replace.

**OK**

Check and replace engine ECU (See page IN-34).