

DTC	P1520	Stop Light Switch Signal Malfunction
------------	--------------	---

CIRCUIT DESCRIPTION

This signal is used to detect when the brakes have been applied. The STP signal voltage is the same as the voltage supplied to the stop lights.

The STP signal is used mainly to control the fuel cut-off engine speed (The fuel cut-off engine speed is reduced slightly when the vehicle is braking.).

DTC No.	DTC Detecting Condition	Trouble Area
P1520	The stop light switch does not turn off even once the vehicle is driven (2 trip detection logic)	<ul style="list-style-type: none"> • Short in stop light switch signal circuit • Stop light switch • Engine ECU

WIRING DIAGRAM

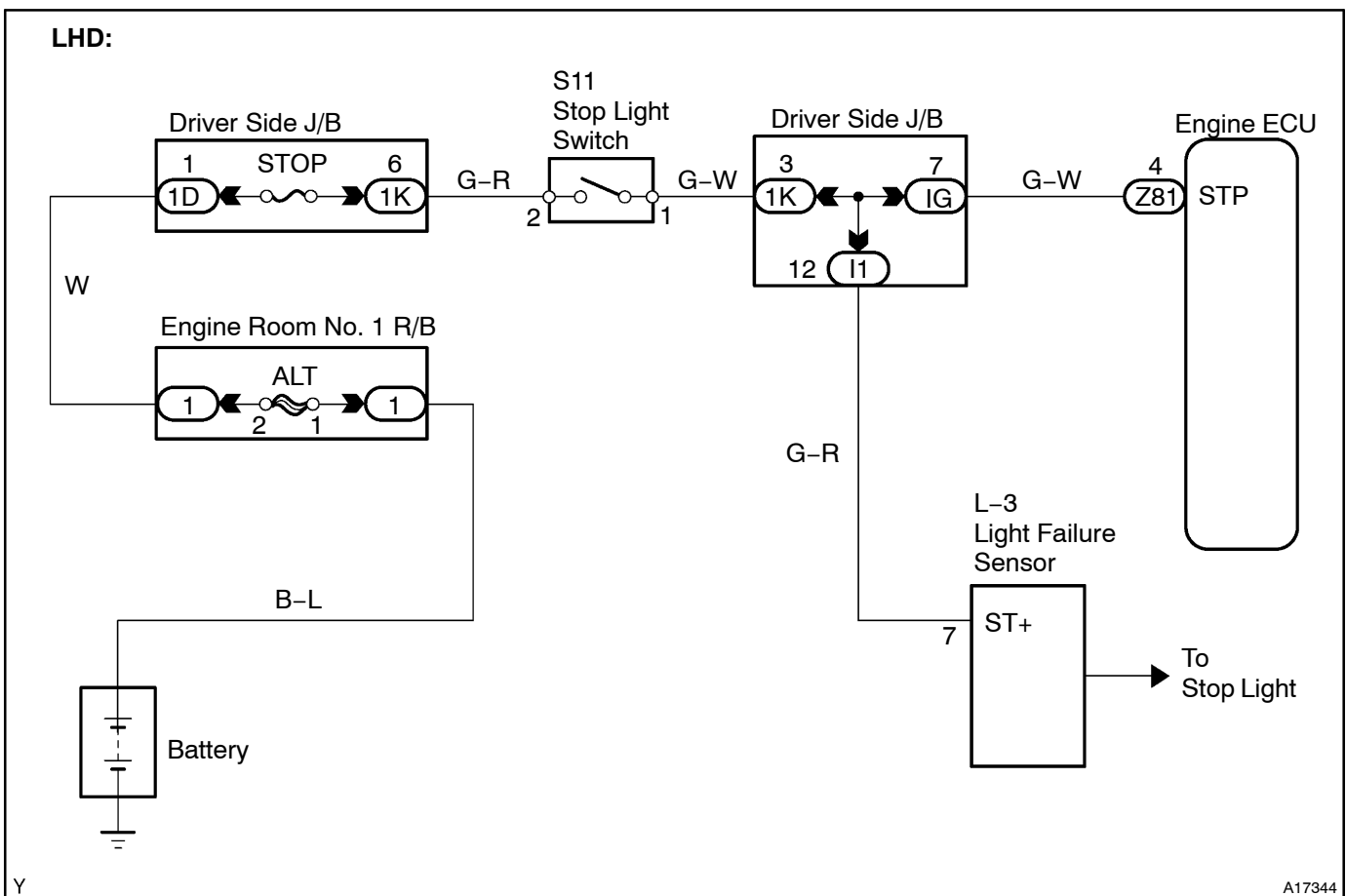

Y

A17344

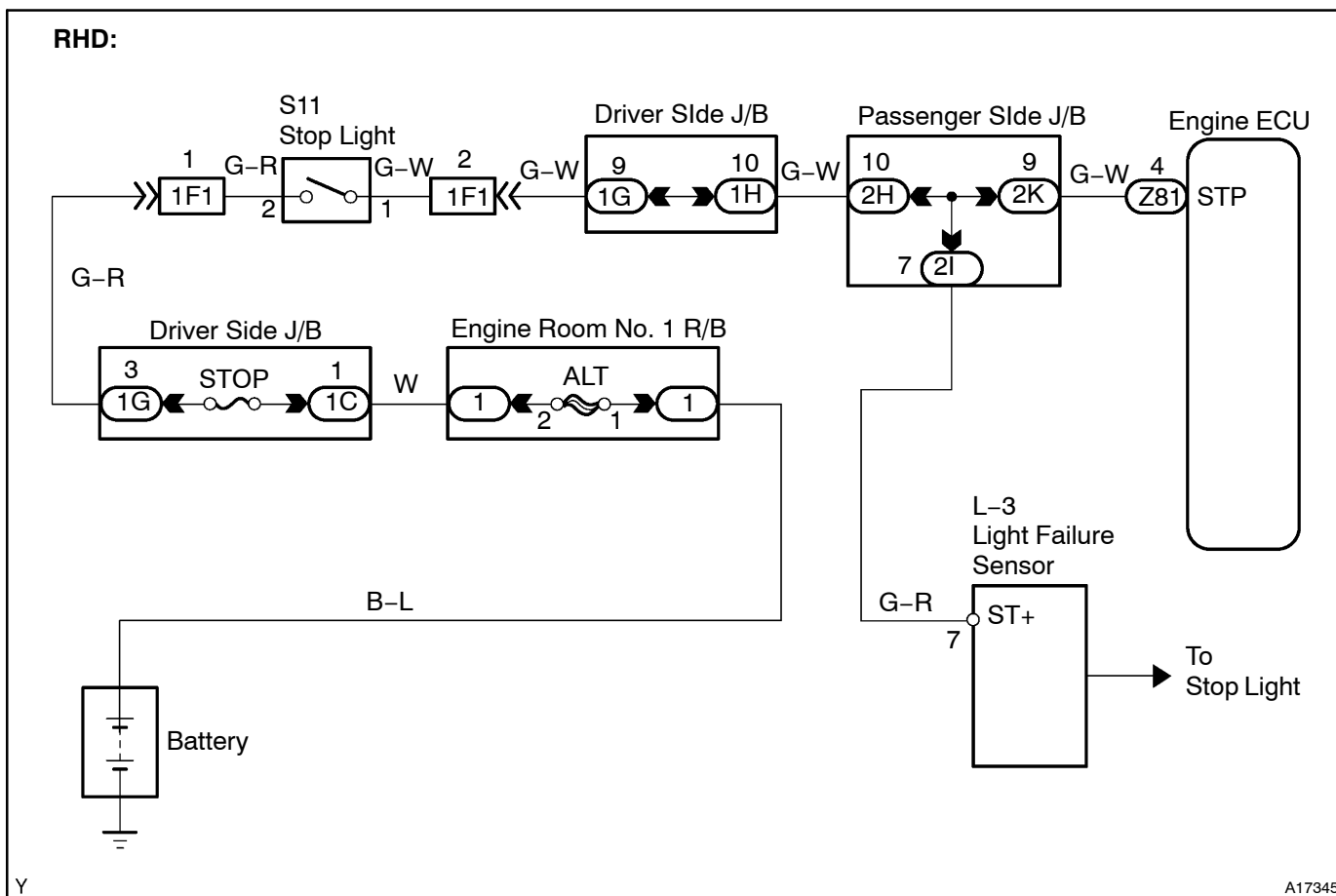

INSPECTION PROCEDURE

HINT:

Read freeze frame data using hand-held tester. Because freeze frame records the engine conditions when the malfunction is detected, when troubleshooting it is useful for determining whether the vehicle was running or stopped, the engine was warmed up or not, the air-fuel ratio was lean or rich, etc. at the time of the malfunction.

- | | |
|----------|---------------------------------------|
| 1 | Check operation of stop light. |
|----------|---------------------------------------|

CHECK:

Check if the stop lights go on and off normally when the brake pedal is operated and released.

NG

Check and repair stop light circuit.

OK

2 Check STP signal.

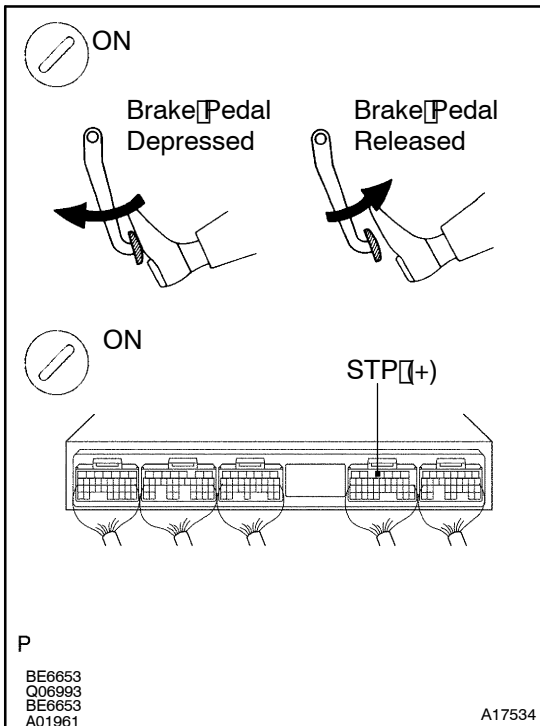

When using hand-held tester:

PREPARATION:

- Connect the hand-held tester to the DLC3.
- Turn the ignition switch ON and hand-held tester main switch ON.

CHECK:

Read the STP signal on the hand-held tester.

OK:

Brake pedal is depressed: STP...ON

Brake pedal is released: STP...OFF

When not using TOYOTA hand-held tester:

PREPARATION:

Turn the ignition switch ON.

CHECK:

Check voltage between terminal STP of the engine ECU and body ground.

OK:

Brake pedal	Voltage
Depressed	7.5 - 14V
Released	Below 0.5V

OK

Check for intermittent problems (See page DI-4).

NG

3 Check harness and connector between engine ECU and stop light switch (See page IN-34).

NG

Repair or replace harness or connector.

OK

Check and replace engine ECU (See page IN-34).