

CIRCUIT INSPECTION

DTC	C0200 / 31 - C1239 / 39	Speed Sensor Circuit
------------	--------------------------------	-----------------------------

CIRCUIT DESCRIPTION

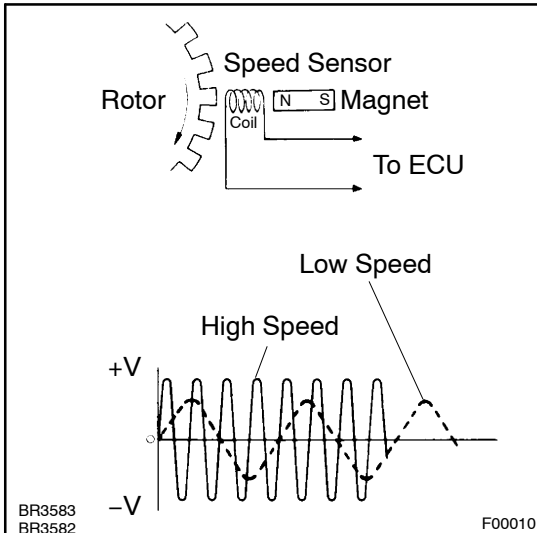

The speed sensor measures wheel speed and sends the corresponding signals to the ECU. These signals are used for control of both the ABS & TRC control system. Both the front and rear rotors have 48 serrations.

When the rotors rotate, the magnetic field emitted by the permanent magnet in the speed sensor generates an AC voltage. Since the frequency of this AC voltage changes in direct proportion to the speed of the rotor, the frequency is used by the ECU to measure the speed of each wheel.

DTC No.	DTC Detecting Condition	Trouble Area
C0200 / 31 C0205 / 32 C0210 / 33 C0215 / 34	Detection of any of conditions 1. through 3.: 1. At vehicle speed of 10 km/h (6 mph) or more, open or short circuit of the speed sensor signal circuit continues for 15 sec. 2. Momentary interruption of the speed sensor signal occurs 7 times or more. 3. Open circuit of the speed sensor signal circuit continues for 0.5 sec. or more.	<ul style="list-style-type: none"> • Right front, left front, right rear, left rear speed sensor • Each speed sensor circuit • Sensor rotor
C1235 / 35 C1236 / 36 C1238 / 38 C1239 / 39	Nose have been counted 75 times in 5 sec.	<ul style="list-style-type: none"> • Right front, left front, right rear, left rear speed sensor • Sensor rotor

HINT:

- DTC No. C0200 / 31 and C1235 / 35 are for the right front speed sensor.
- DTC No. C0205 / 32 and C1236 / 36 are for the left front speed sensor.
- DTC No. C0210 / 33 and C1238 / 38 are for the right rear speed sensor.
- DTC No. C0215 / 34 and C1239 / 39 are for the left rear speed sensor.

WIRING DIAGRAM

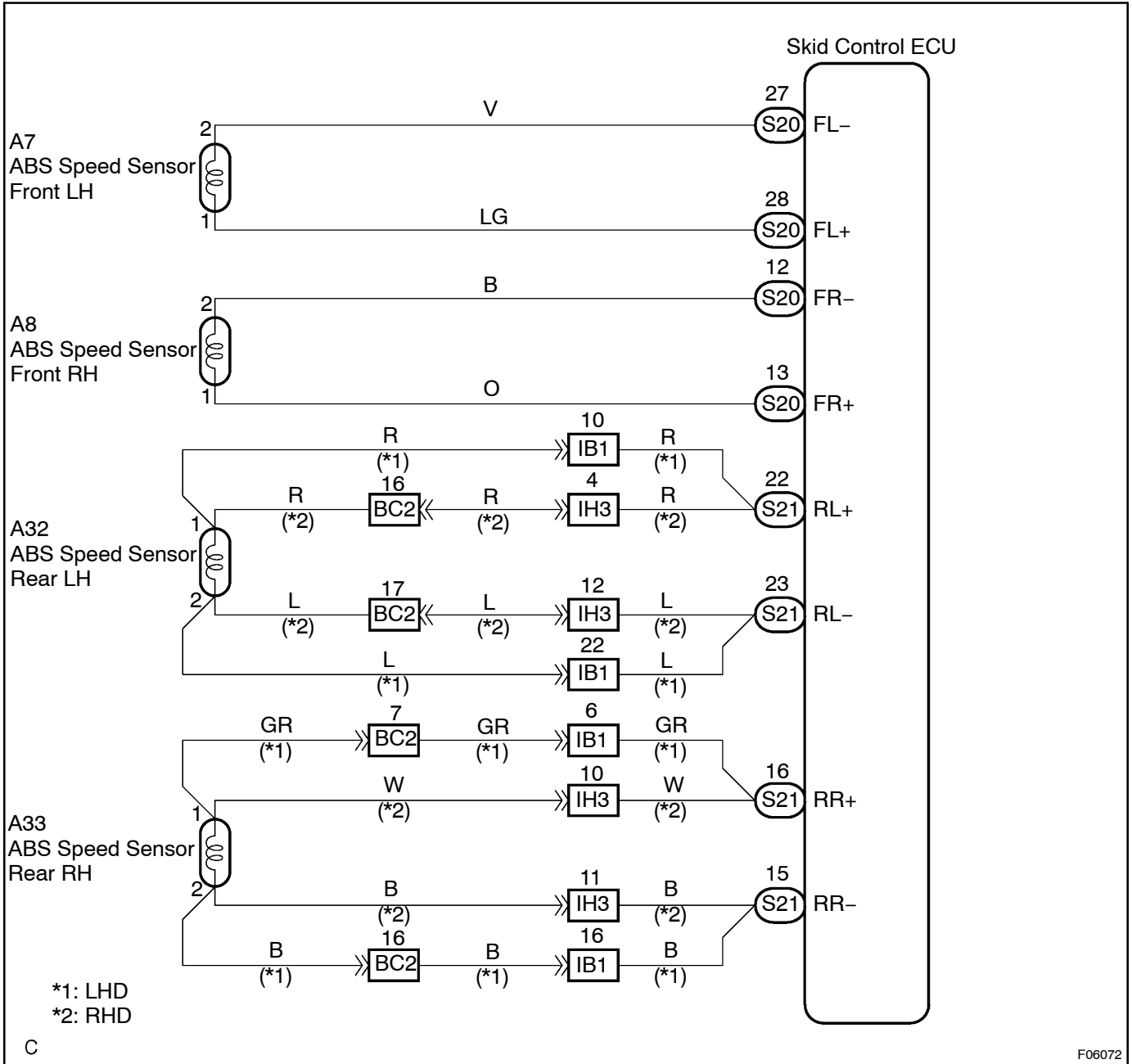

INSPECTION PROCEDURE

HINT:

Start the inspection from step 1 in case of using the hand-held tester and start from step 2 in case of not using the hand-held tester.

1	Check output value of speed sensor.
----------	--

PREPARATION:

- (a) Connect the hand-held tester to the DLC3.
- (b) Turn the ignition switch ON and turn the hand-held tester main switch ON.
- (c) Select the DATALIST mode on the hand-held tester.

CHECK:

Check that there is no difference between the speed value output from the speed sensor observed in the hand-held tester and the speed value displayed by the speedometer when the vehicle is in motion.

OK:

There is almost no difference in the displayed speed values.

HINT:

There is tolerance of $\pm 10\%$ in the speedometer indication.

OK

Go to step 4.

NG

2	Check speed sensor.
----------	----------------------------

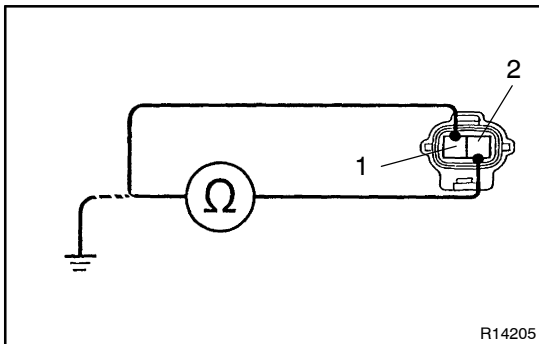

Front:

PREPARATION:

- (a) Make sure that the speed sensor connector and the wire harness side connector are securely connected.
- (b) Disconnect the speed sensor connector.

CHECK:

Measure resistance between terminals 1 and 2 of the speed sensor connector.

OK:

Resistance: 1.4 – 1.8 kΩ at 20°C

CHECK:

Measure resistance between terminals 1 and 2 of the speed sensor connector and body ground.

OK:

Resistance: 1 MΩ or higher

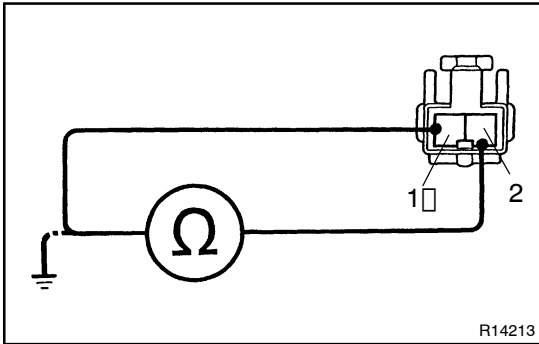
**Rear:****PREPARATION:**

- (a) Remove the rear seat cushion and the seatback.
- (b) Make sure that the speed sensor connector and the wire harness side connector are securely connected.
- (c) Disconnect the speed sensor connector.

CHECK:

Measure resistance between terminals 1 and 2 of the speed sensor connector.

OK:

Resistance: 0.9 – 1.3 kΩ at 25 ± 5° C

CHECK:

Measure resistance between terminals 1 and 2 of the speed sensor connector and body ground.

OK:

Resistance: 1 MΩ or higher



Replace speed sensor.

NOTICE:

Check the speed sensor signal last (See page DI-251).

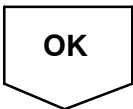

OK

3 Check for open and short circuit in harness and connector between each speed sensor and skid control ECU (See page IN-34).



Repair or replace harness or connector.

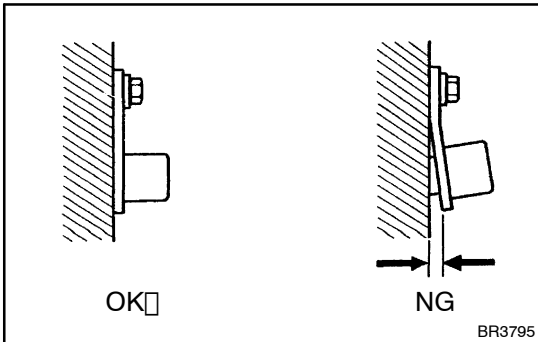

OK

4 Check sensor installation.**CHECK:**

Check the speed sensor installation.

OK:

The installation bolt is tightened properly and there is no clearance between the sensor and front steering knuckle or rear axle carrier.

NG

Replace speed sensor.

NOTICE:

Check the speed sensor signal last (See page DI-251).

OK

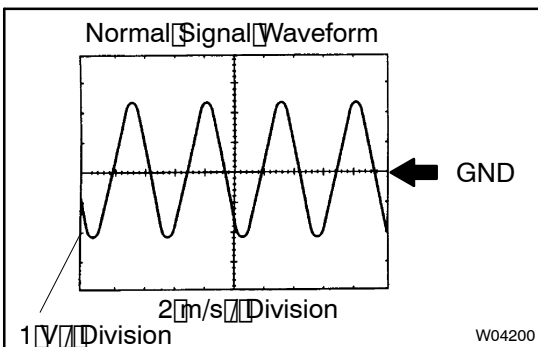
5 Check speed sensor and sensor rotor serrations.**(REFERENCE) INSPECTION USING OSCILLOSCOPE****PREPARATION:**

- Remove the skid control ECU with the connector still connected.
- Connect the oscilloscope to the terminals FR+ – FR–, FL+ – FL–, RR+ – RR– and RL+ – RL– of the skid control ECU.

CHECK:

Drive the vehicle at the speed of about 20 km/h (12 mph), and check the signal waveform.

HINT:

- As the vehicle speed (rpm of the wheels) increases, a cycle of the waveform becomes shorter and the fluctuation in the output voltage becomes greater.
- When noise is identified in the waveform on the oscilloscope, error signals are generated due to the speed sensor rotor's scratches, looseness or foreign matter deposited on it.

OK

Check and replace skid control ECU.

NG

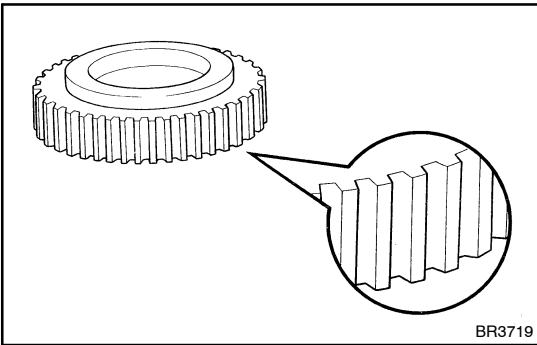
6 Check sensor rotor and sensor tip.**Front:****PREPARATION:**

Remove the front axle hub and the speed sensor.

CHECK:

Check the sensor rotor serrations.

OK:

No scratches, missing teeth or foreign objects on the sensor rotor.

CHECK:

Check the sensor tip.

OK:

No scratches or foreign objects on the sensor tip.

HINT:

If foreign matter (including that on the sensor rotor side) is identified, remove it and after reassembling, check the output waveform.

Rear:**PREPARATION:**

Remove the drive shaft.

CHECK:

Check the sensor rotor serrations.

OK:

No scratches, missing teeth or foreign objects.

PREPARATION:

Remove the rear speed sensor.

CHECK:

Check the sensor tip.

OK:

No scratches or foreign objects on the sensor tip.

HINT:

If foreign matter (including that on the sensor rotor side) is identified, remove it and after reassembling, check the output waveform.

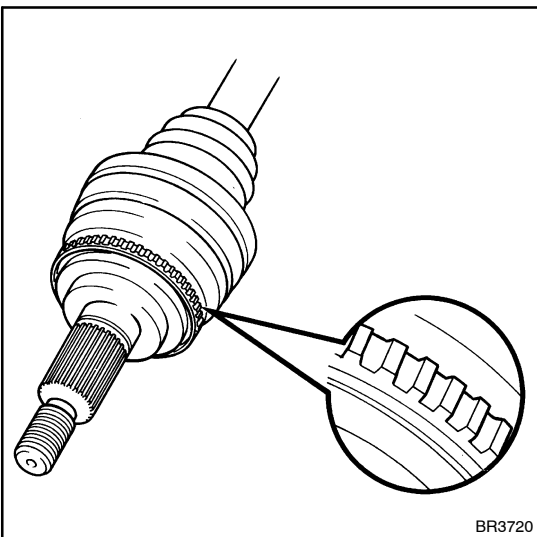
**NG****Replace speed sensor or rotor.****NOTICE:**

Check the speed sensor signal last ([See page DI-251](#)).

OK**Check and replace skid control ECU.**