

DTC	C0273 / 13, C0274 / 14	ABS Motor Relay Circuit
------------	-------------------------------	--------------------------------

CIRCUIT DESCRIPTION

The ABS motor relay supplies power to the ABS pump motor. While the ABS & TRC are activated, the ECU switches the motor relay ON and operates the ABS pump motor.

DTC No.	DTC Detecting Condition	Trouble Area
C0273 / 13	Conditions 1. and 2. continued for 0.12 sec. or more: 1. ECU terminal IG1 voltage is 9.5 V to 17.2 V in the initial check or ABS, TRC are in operation, and when the motor relay is ON, however, the contact point of the motor relay is OFF. 2. ECU terminal IG1 is 9.5 V or less, and when the motor relay is ON, but the contact point of the motor relay does not become ON.	<ul style="list-style-type: none"> • ABS motor relay • ABS motor relay circuit • Skid control ECU
C0274 / 14	When the motor relay is OFF, the condition that the contact point of motor relay is ON continues for 4 sec. or more.	

WIRING DIAGRAM

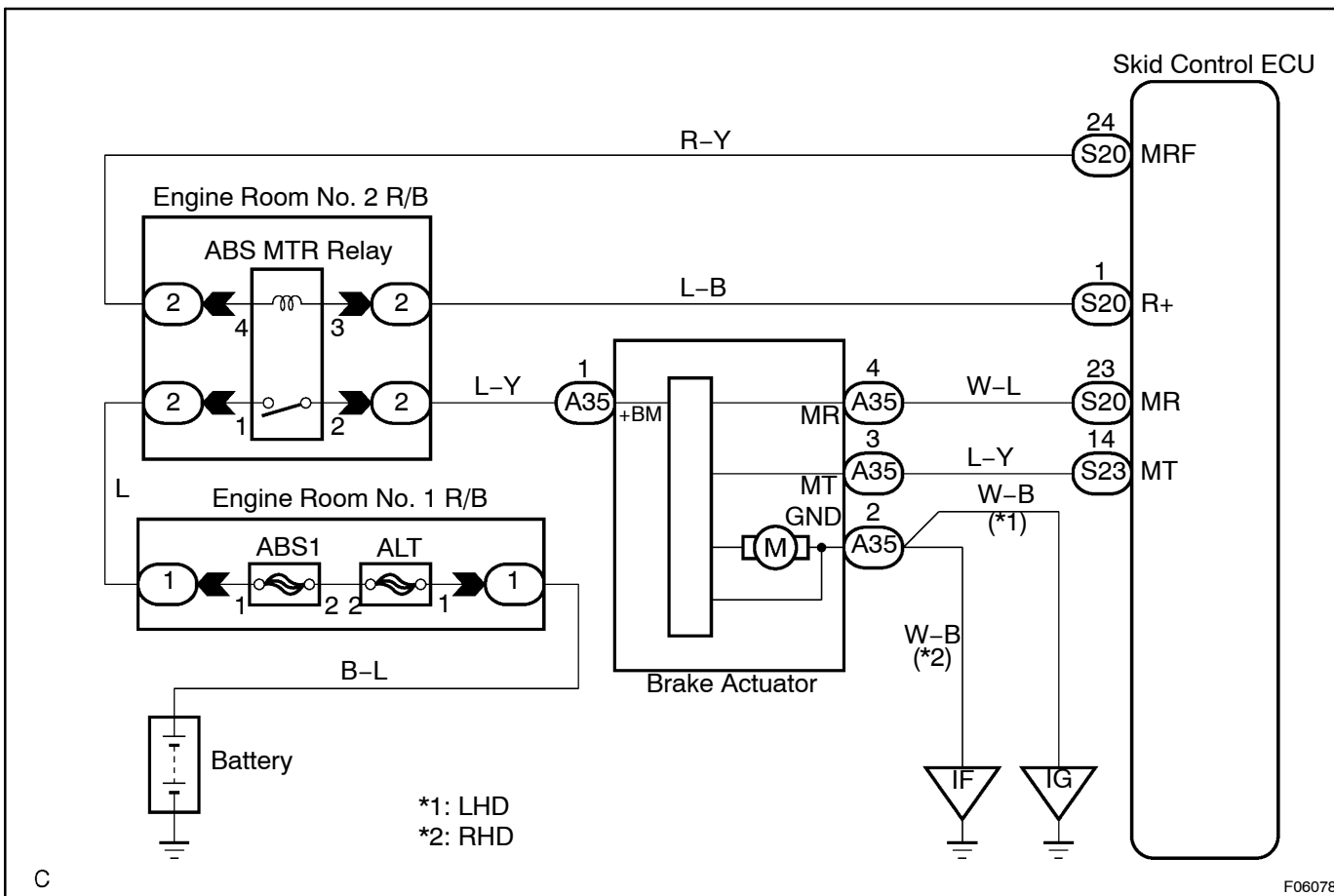

INSPECTION PROCEDURE

HINT:

Start the inspection from step 1 in case of using the hand-held tester and start from step 2 in case of not using hand-held tester.

1 Check ABS motor relay operation.

PREPARATION:

- (a) Connect the hand-held tester to the DLC3.
- (b) Turn the ignition switch ON and push the hand-held tester main switch ON.
- (c) Select the ACTIVE TEST mode on the hand-held tester.

CHECK:

Check the operation sound of the ABS motor relay when operating it with the hand-held tester.

OK:

The operation sound of the ABS motor relay should be heard.

OK

Go to step 4.

NG

2 Check voltage between terminal 1 of engine room No. 2 R/B (for ABS motor relay) and body ground.

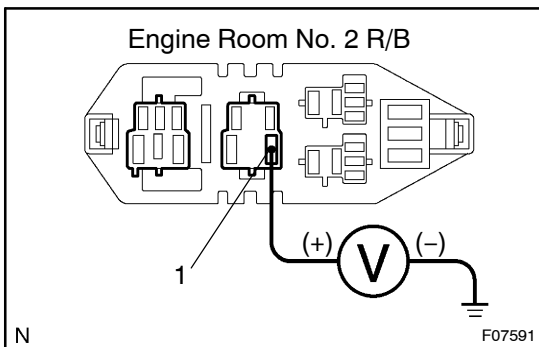

PREPARATION:

Remove the ABS motor relay from the engine room No. 2 R/B.

CHECK:

Measure voltage between terminal 1 of engine room No. 2 R/B (for ABS motor relay) and body ground.

OK:

Voltage: 10 - 14 V

NG

Check and repair harness or connector.

OK

3 Check ABS motor relay.

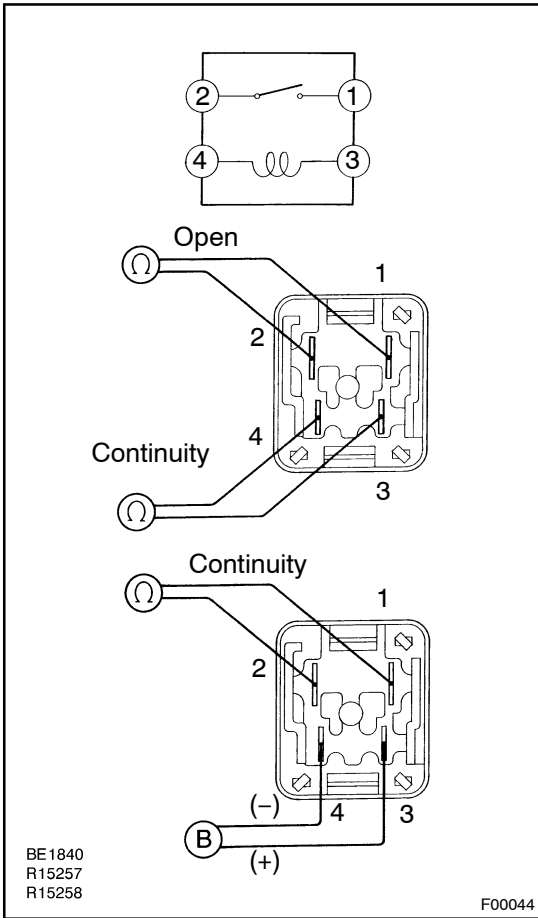

CHECK:

Check continuity between each pair of terminal of motor relay.

OK:

Terminals 3 and 4	Continuity (Reference value 62 Ω)
Terminals 1 and 2	Open

CHECK:

- (a) Apply battery voltage between terminals 3 and 4.
- (b) Check continuity between terminals.

OK:

Terminals 1 and 2	Continuity
-------------------	------------

NG Replace ABS motor relay.

OK

4 Check continuity between terminals 2 of engine room No. 2 R/B (for ABS motor relay) and terminal MT of skid control ECU.

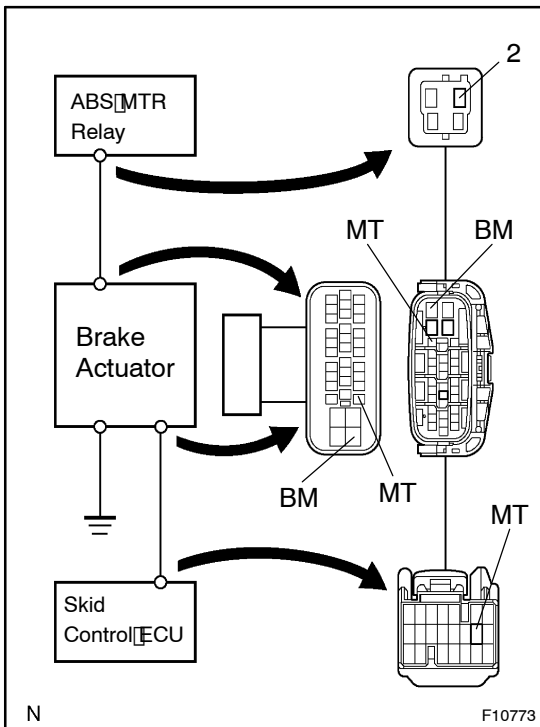

PREPARATION:

- Remove the ABS motor relay from the engine room No. 2 R/B.
- Disconnect the connector from the skid control ECU.

CHECK:

Check continuity between terminals 2 of engine room No. 2 R/B (for ABS motor relay) and terminal MT of skid control ECU harness side connector.

OK:

Continuity

HINT:

There is no continuity between terminals BM and MT of brake actuator.

NG

Repair or replace harness or brake actuator.

OK

5 Check for open and short circuit in harness and connector between ABS motor relay and skid control ECU (See page IN-34).

NG

Repair or replace harness or connector.

OK

If the same code is still output after the DTC is deleted, check the contact condition of each connection. If the connections are normal, the ECU may be defective.