

DTC	C0226 / 21 - C0256 / 24	ABS-Related Solenoid Circuits
------------	--------------------------------	--------------------------------------

CIRCUIT DESCRIPTION

ABS-related solenoids operate when signals are received from the ECU, and control the pressure acting on the wheel cylinders thus controlling the braking force.

DTC No.	DTC Detecting Condition	Trouble Area
C0226 / 21	Open or short circuit for SFRH or SFRR circuit continues for 0.05 sec. or more.	<ul style="list-style-type: none"> • Brake actuator • SFRH or SFRR circuit
C0236 / 22	Open or short circuit for SFLH or SFLR circuit continues for 0.05 sec. or more.	<ul style="list-style-type: none"> • Brake actuator • SFLH or SFLR circuit
C0246 / 23	Open or short circuit for SRRH or SRRR circuit continues for 0.05 sec. or more.	<ul style="list-style-type: none"> • Brake actuator • SRRH or SRRR circuit
C0256 / 24	Open or short circuit for SRLH or SRLR circuit continues for 0.05 sec. or more.	<ul style="list-style-type: none"> • Brake actuator • SRLH or SRLR circuit

WIRING DIAGRAM

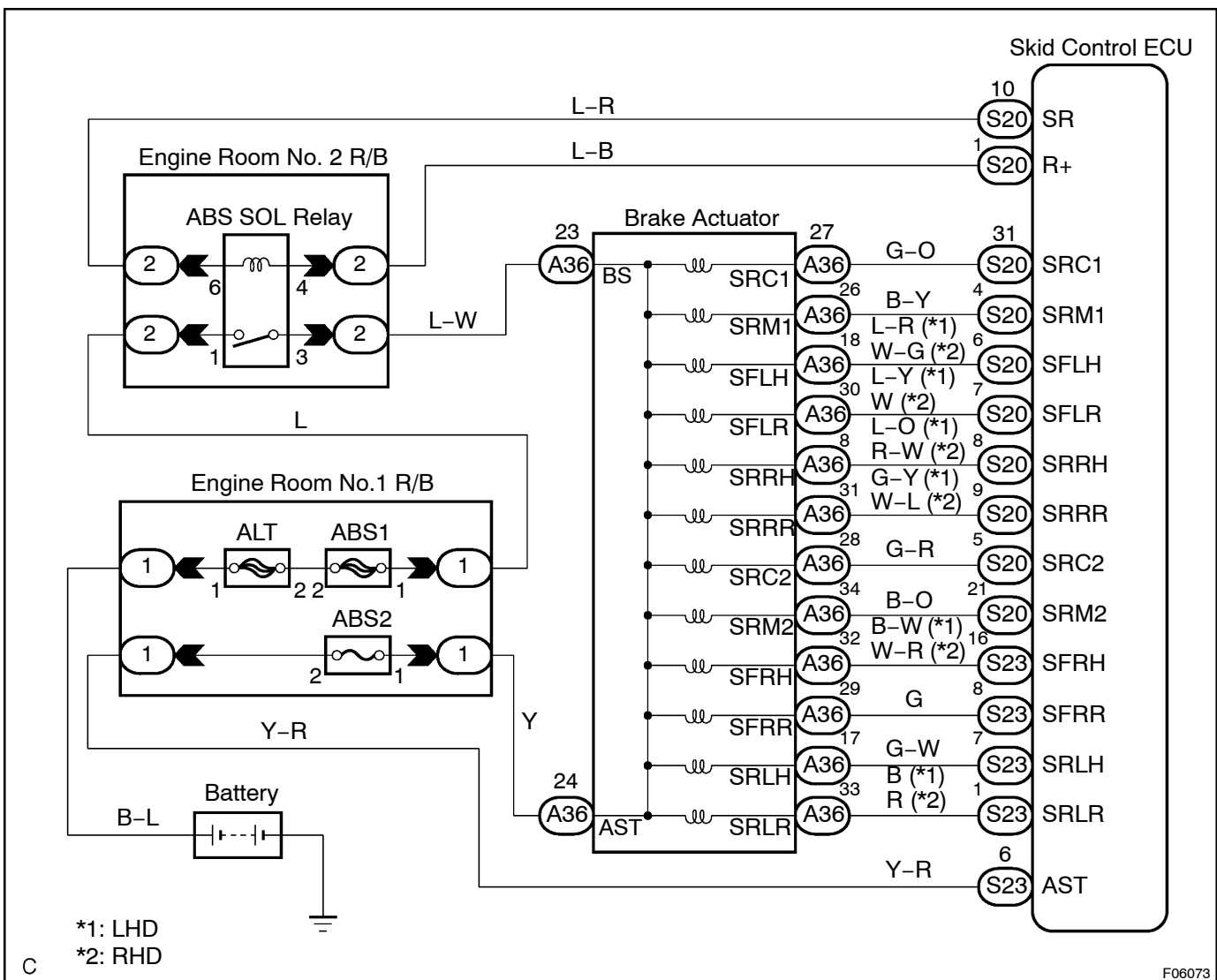

INSPECTION PROCEDURE

1 Check brake actuator solenoid.

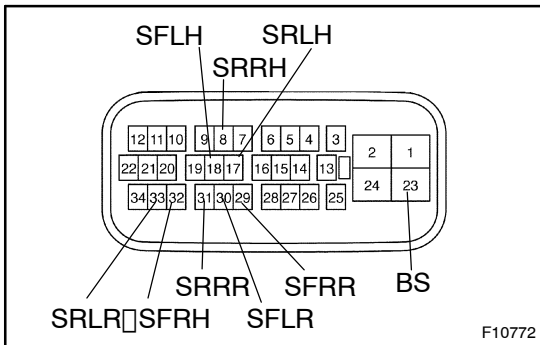
**PREPARATION:**

- (a) Turn the ignition switch OFF.
- (b) Disconnect the brake actuator connector.

CHECK:

Check continuity between terminal BS and terminals SFRH, SFLH, SRRH, SRLH, SFRR, SFLR, SRRR and SRLR of brake actuator.

OK:**Continuity****HINT:**

Resistance of each solenoid at 25°C

SFRH, SFLH, SRRH, SRLH: 8.1 - 9.1 Ω

SFRR, SFLR, SRRR, SRLR: 4.0 - 4.6 Ω

NG

Replace brake actuator.

OK

2 Check for open and short circuit in harness and connector between skid control ECU and brake actuator (See page IN-34).

NG

Repair or replace harness or connector.

OK

If the same code is still output after the DTC is deleted, check the contact condition of each connection. If the connections are normal, the ECU may be defective.