

DTC	C1251 / 51	ABS Pump Motor Lock
------------	-------------------	----------------------------

CIRCUIT DESCRIPTION

DTC No.	DTC Detecting Condition	Trouble Area
C1251 / 51	Either of the following 1. or 2. is detected: 1. Actuator drive motor is not operating normally. 2. Open circuit condition of actuator drive motor continues for 2 sec. or more.	<ul style="list-style-type: none"> • Brake Actuator • Brake Actuator Circuit

WIRING DIAGRAM

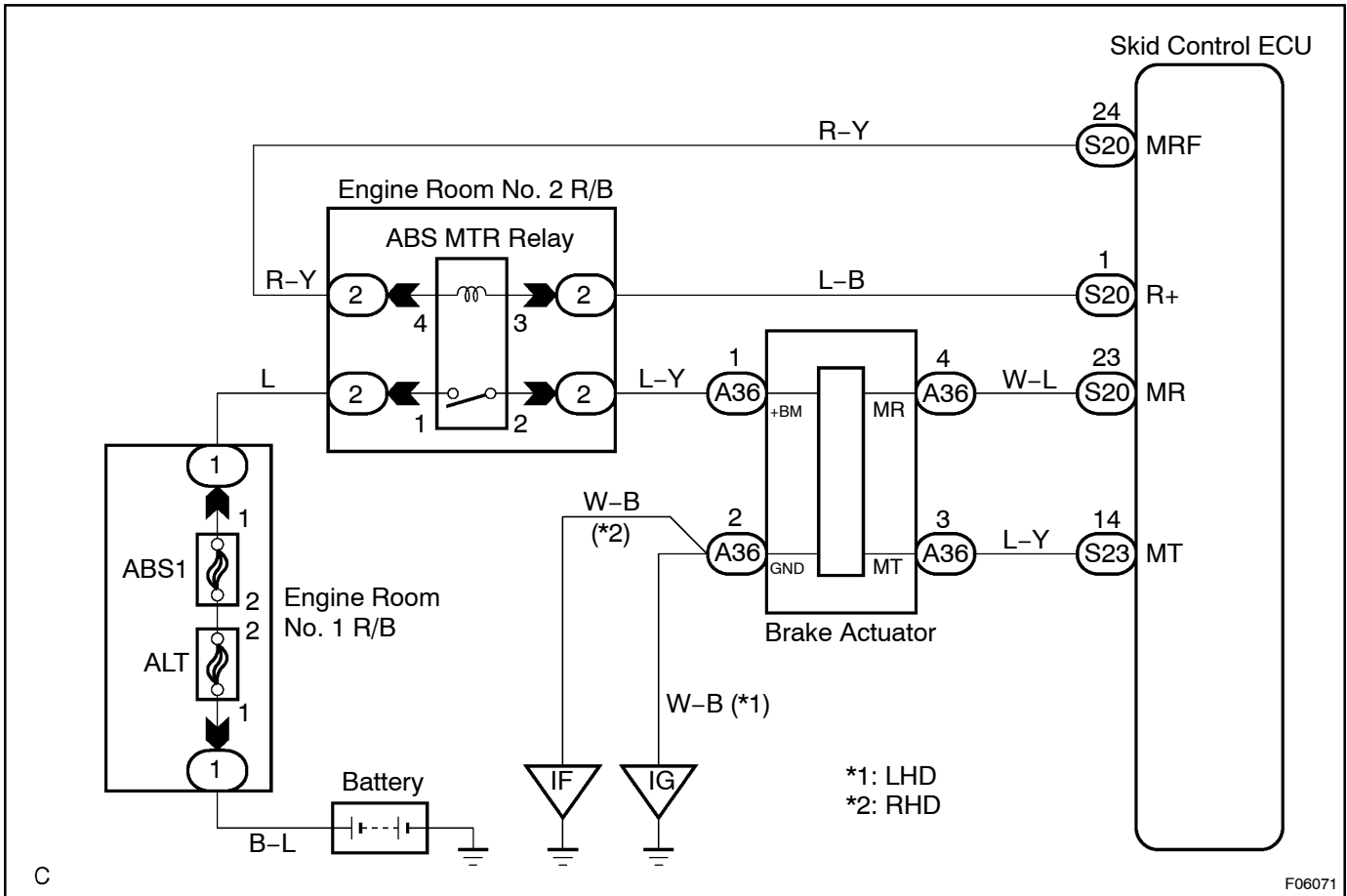

INSPECTION PROCEDURE**HINT:**

Start the inspection from step 1 in case of using the hand-held tester and start from step 2 in case of not using hand-held tester.

1 Check ABS motor operation.

PREPARATION:

- (a) Connect the hand-held tester to the DLC3.
- (b) Turn the ignition switch ON and push the hand-held tester main switch ON.
- (c) Select the ACTIVE TEST mode on the hand-held tester.

CHECK:

Check the operation sound of the ABS motor when operating it with the hand-held tester.

OK:

The operation sound of the ABS motor should be heard.

NG

Replace brake actuator.

OK

2 Is there DTC C1251/51 being output again?

YES

Check and replace skid control ECU
(See page N-30).

NO

No problem.