

DTC	B2797/99	Communication Malfunction No.1
------------	-----------------	---------------------------------------

CIRCUIT DESCRIPTION

This code is detected when although the communication has been performed normally, an error occurs. (Example. Some noise is included in communication line.)

DTC No.	DTC Detecting Condition	Trouble Area
B2797/99	Communication error	<ul style="list-style-type: none"> • Wire Harness • Transponder Key Amplifier • Engine and ECT ECU

WIRING DIAGRAM

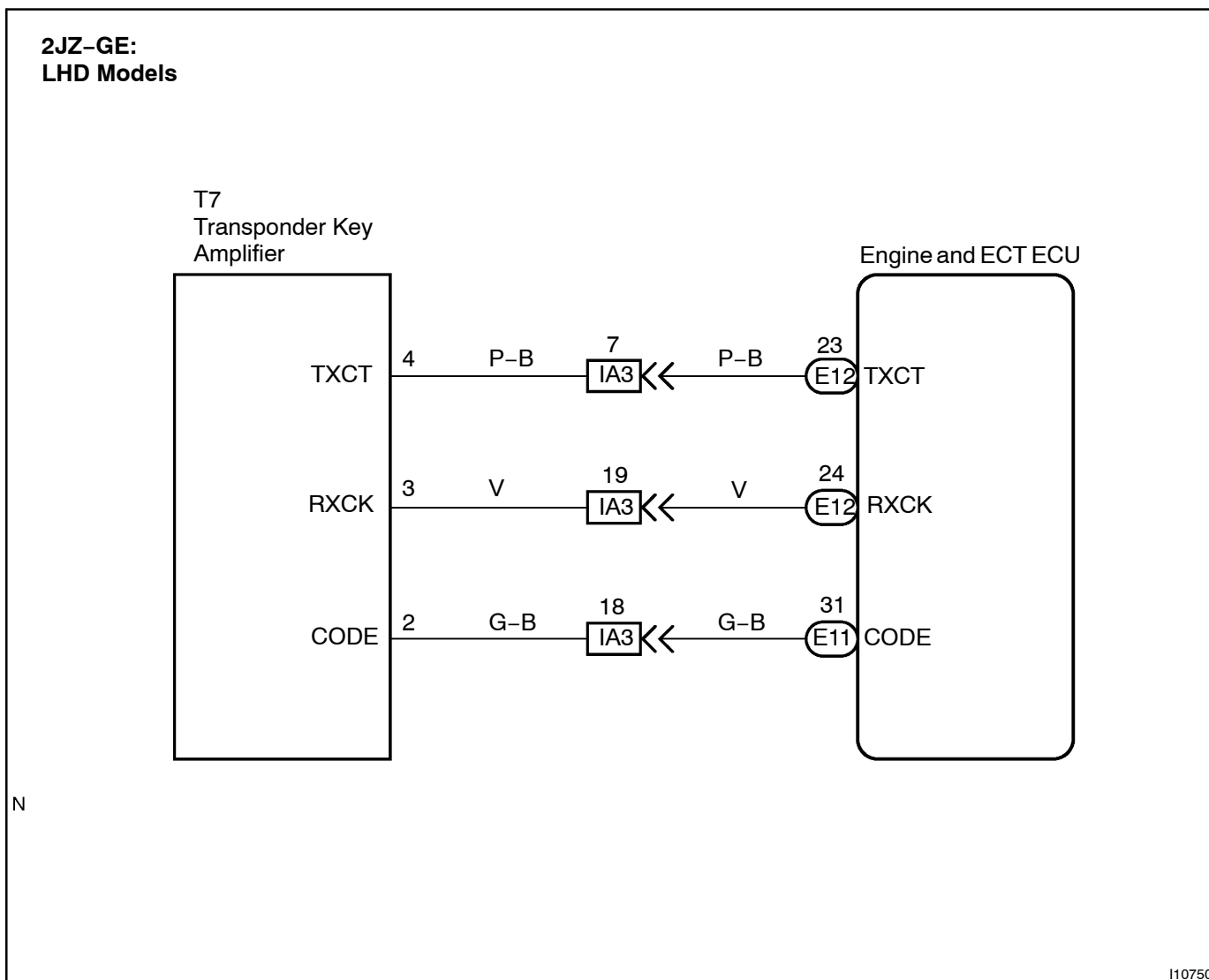

2JZ-GE:
RHD Models

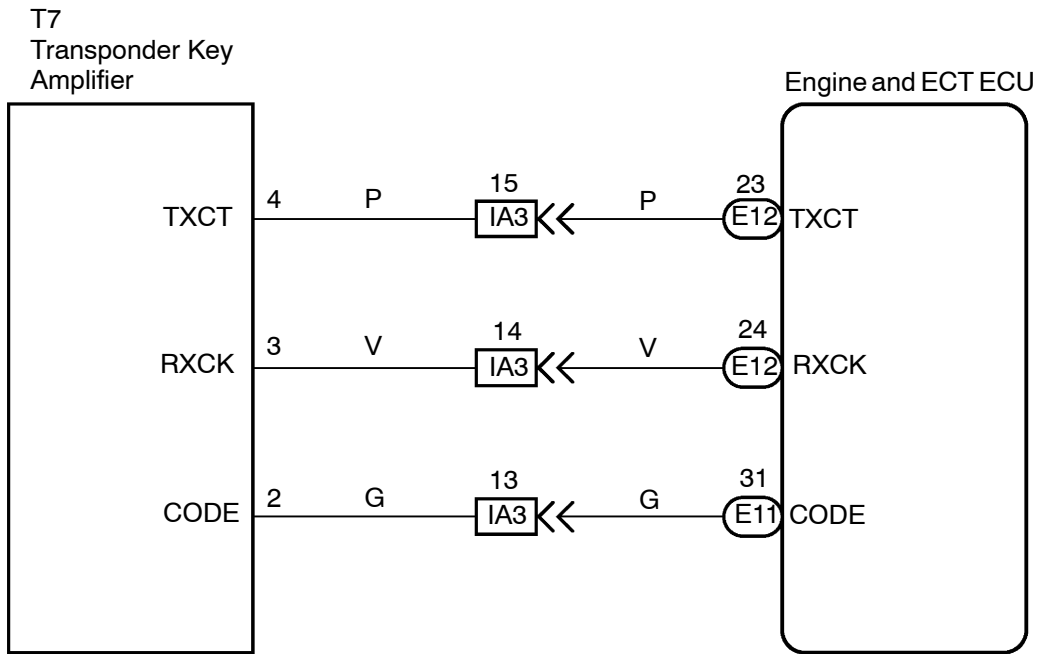

N

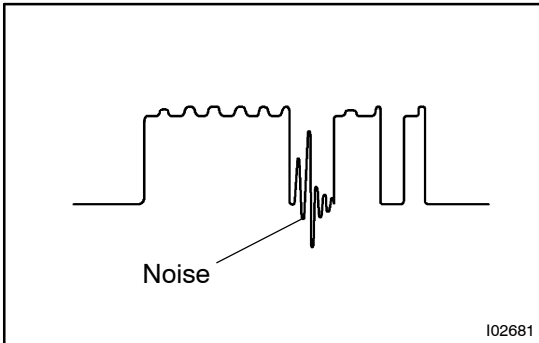
INSPECTION PROCEDURE**1 Noise check****PREPARATION:**

Insert the already registered master key in the key cylinder.

CHECK:

Using an oscilloscope or hand-held tester, check that noise is included in the signals sent to the CODE terminal of Engine and ECT ECU.

OK:

No noise is detected.

NG

Try to find the cause of the noise and remove it.

OK**2 Does the system operate normally after replacement of transponder key amplifier?****Yes**

Replace transponder key amplifier.

No

Replace Engine and ECT ECU.