

CIRCUIT INSPECTION

Wireless door lock tuner circuit

CIRCUIT DESCRIPTION

The signal from the transmitter will be input to the body ECU through RDA line. RDA line is diagnosed by the Body ECU, so check DTC also in case of the failure of the wireless function.

WIRING DIAGRAM

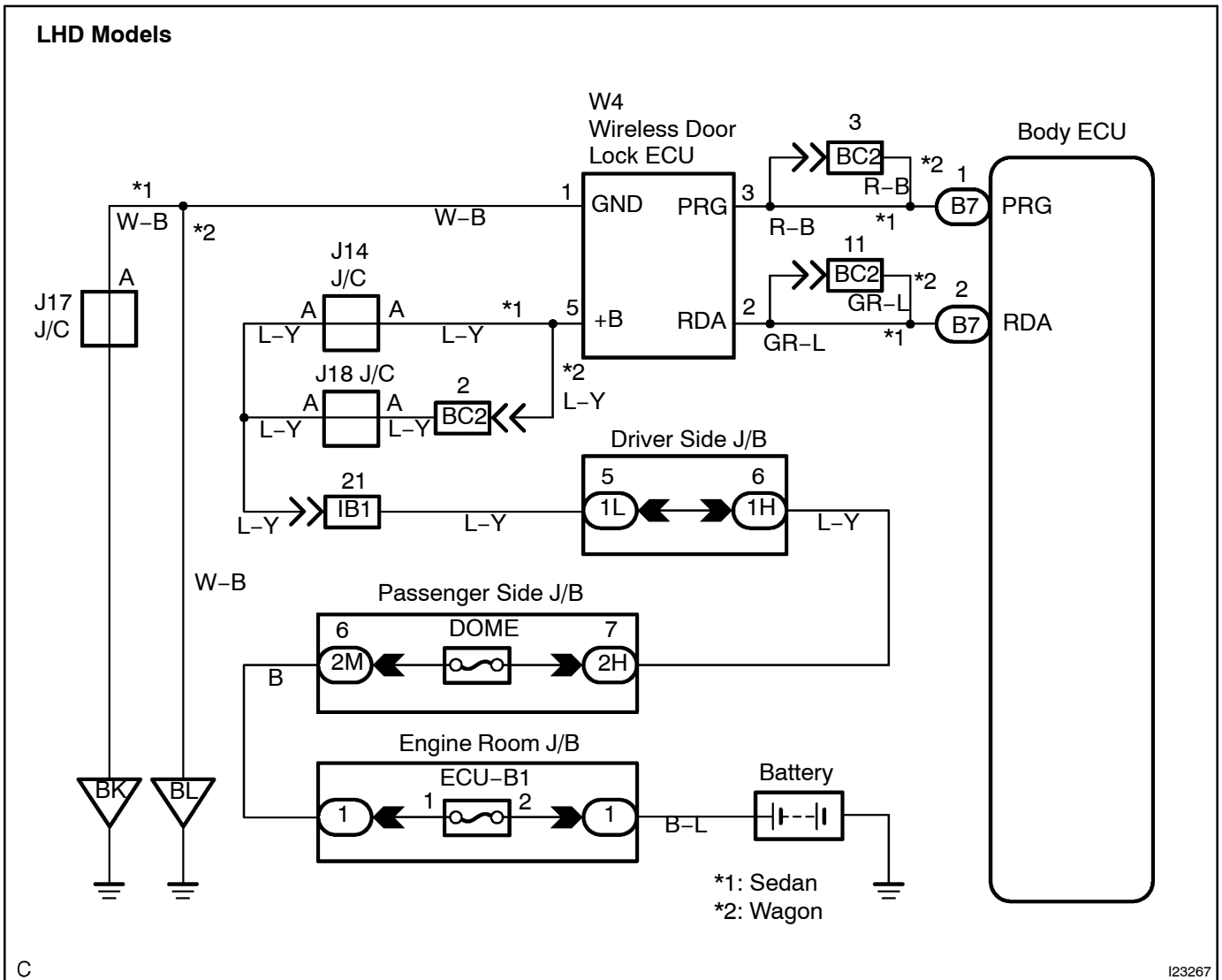

RHD Models

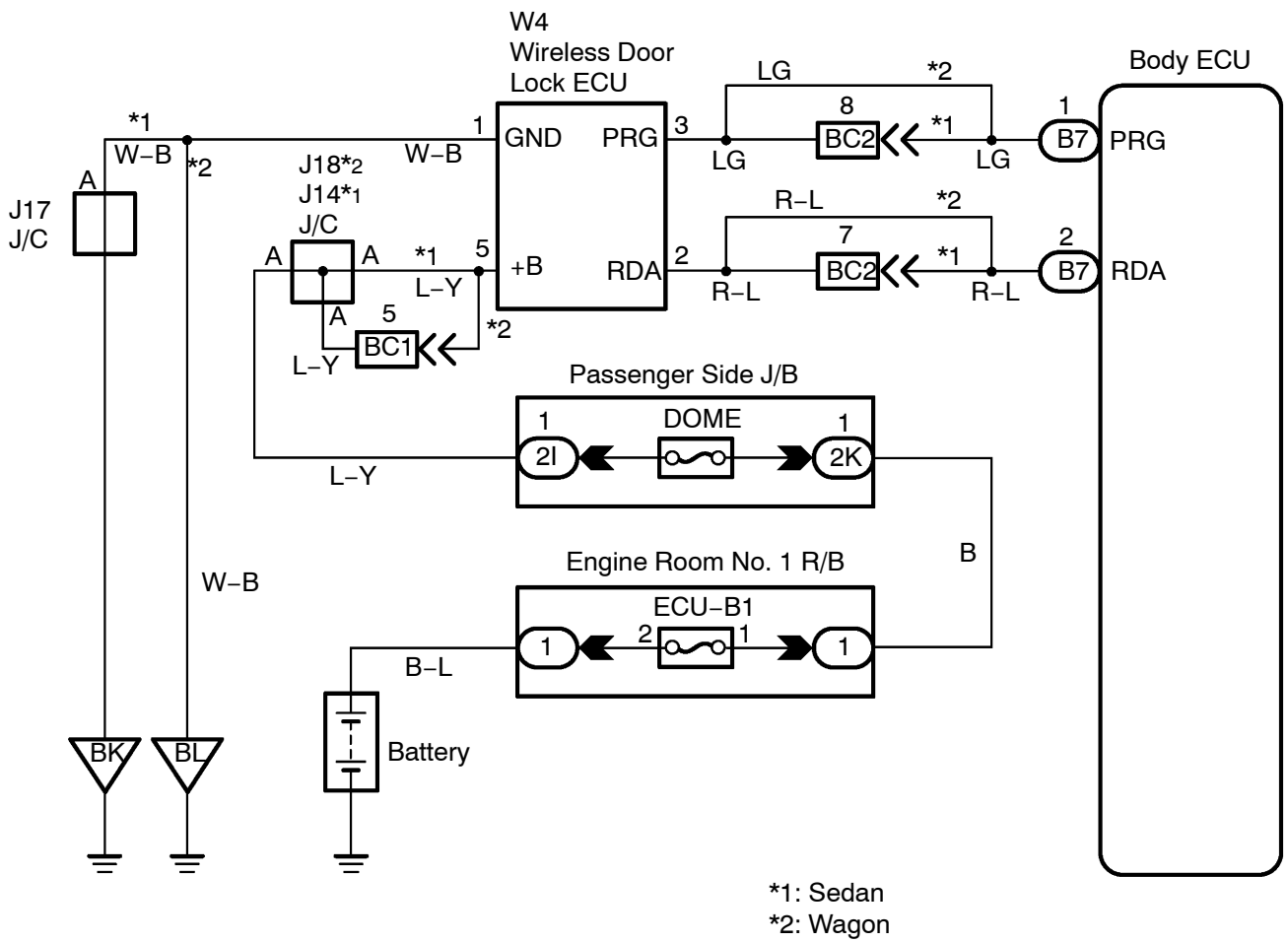

C

123268

INSPECTION PROCEDURE

1 Check that DTC 42 is not output

NG

Check the RDA line.

OK

2 Check wire harness

PREPARATION:

Disconnect connectors of wireless door lock tuner and Body ECU.

CHECK:

Check continuity between terminals PRG of wireless door lock tuner and PRG of Body ECU.

OK:

Continuity

NG

Repair or replace wire harness

OK

3 Check the wireless door lock tuner

CHECK:

Replace the wireless door lock tuner and check if it recovers normally.

OK:

Must be recovered normally.

NG

Proceed to next circuit inspection shown on problem symptoms table. (See page DI-555)

OK

Failure of the original wireless door lock tuner.