

CIRCUIT INSPECTION

AVC-LAN (Communication bus) Circuit

CIRCUIT DESCRIPTION

Each unit of LEXUS navigation system connected with AVC-LAN (communication bus) transfers the signal of each switch by communication.

When +B short and GND short occur in this AVC-LAN, LEXUS navigation system will not function normally as the communication is discontinued.

In this AVC-LAN, Navigation ECU becomes the master of the communication, and the audio head unit has a resistance necessary for transmitting the communication.

Multi Display is connected between Navigation ECU and Audio head unit, LEXUS navigation system has the structure that makes communication impossible without Navigation ECU, Multi Display or Audio head unit.

AVC-LAN

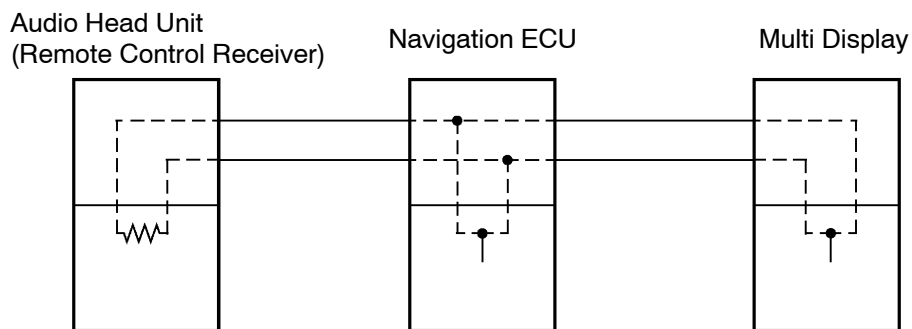

N

I11572

WIRING DIAGRAM

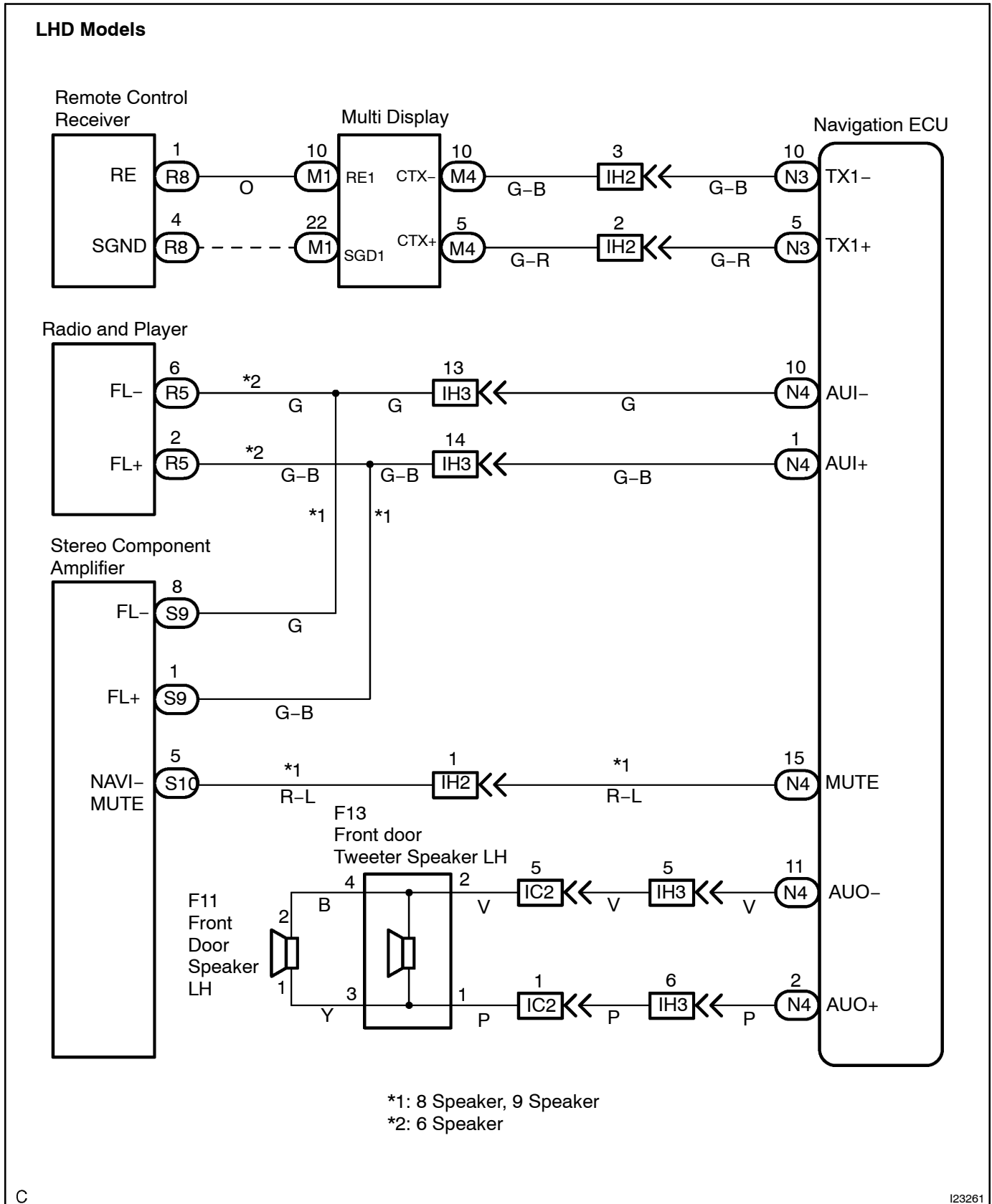

C

I23261

RHD Models

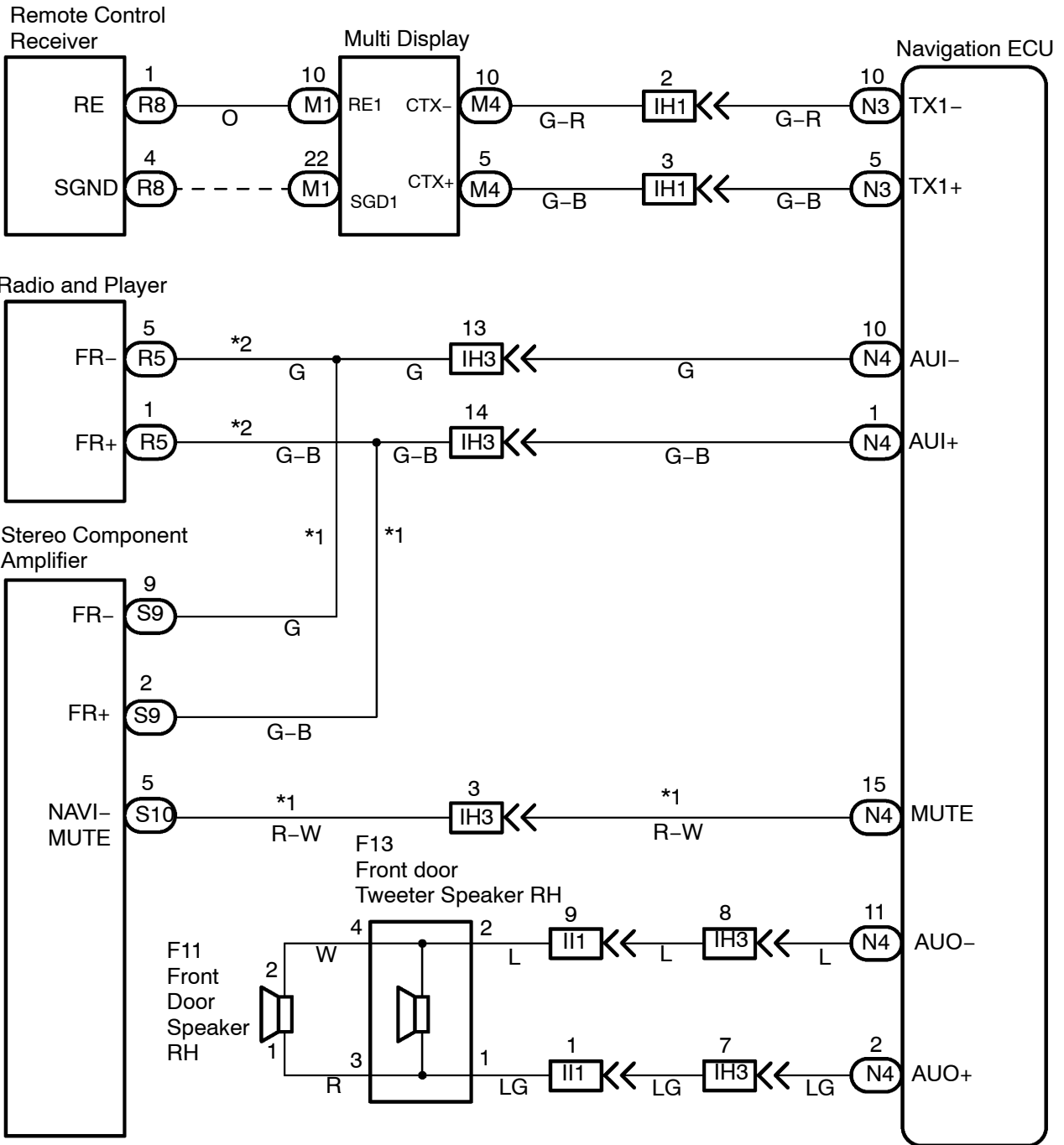

*1: 8 Speaker, 9 Speaker
 *2: 6 Speaker

INSPECTION PROCEDURE

- 1 Disconnect the connector "S8" of power amplifier and check if AVC-LAN will be recovered normally.

CHECK:

Check that the display will change by pressing either of the Panel switch or Touch switch on the display.

HINT:

It can be judged that AVC-LAN is recovered if the display is changed.

OK

Replace the power amplifier

NG

- 2 Check wire harness and connector between radio and player and Navigation ECU. (See page N-34)

NG

Repair or replace wire harness or connector between radio and player and Navigation ECU.

OK

- 3 Check wire harness and connector between Multi Display and Navigation ECU. (See page N-34)

NG

Repair or replace wire harness or connector between Multi Display and Navigation ECU.

OK

4 Skip Display ECU and check AVC-LAN.

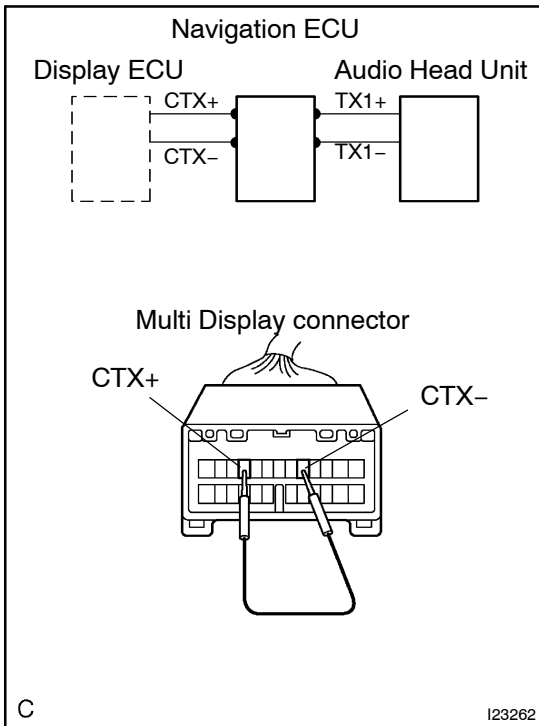

PREPARATION:

- (a) Connect all the connectors except "M1" of the Multi Display.
- (b) Using 2 SSTs (Diagnosis check wire P/N 09893-12040), connect the terminal CTX+ of connector "M1" and CTX+ of connector "M1" of Multi Display.

CHECK:

Operate radio and player (CD, Cassette tape, etc.) and check that the sound comes out from the speaker.

(Check that AVC-LAN is recovered.)

OK

Replace the Multi Display.

NG

5 Skip radio and player and check AVC-LAN.

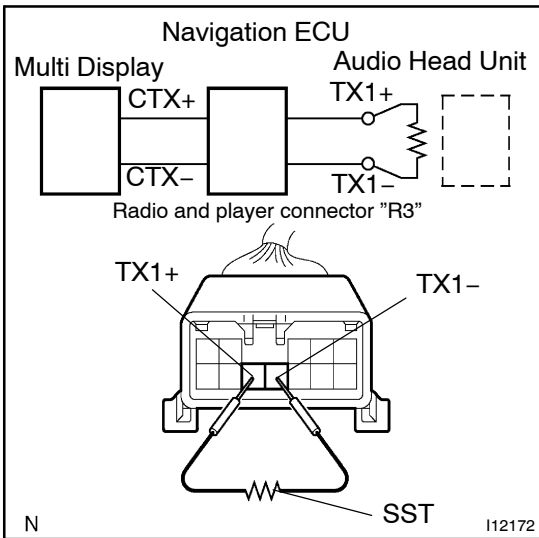

PREPARATION:

- Connect Multi Display connector.
- Disconnect radio and player "F" connector.
- Using SST (Navigation Check Wire P/N 09843-18050), connect the terminal TX1+ to terminal TX1- of "F" connector of radio and player.

CHECK:

Operate the panel switch and the touch switch of the display and check that the navigation functions.

(Check that AVC-LAN is recovered.)

OK

Replace the radio and player.

NG

Replace the Navigation ECU.