

DTC	B1431	Air Mix Damper Position Sensor Circuit
------------	--------------	---

CIRCUIT DESCRIPTION

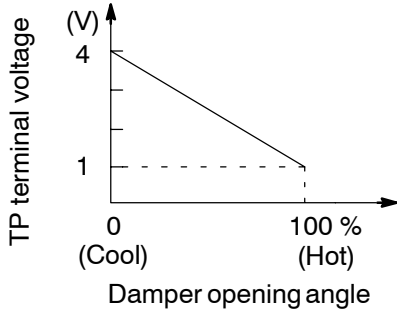

This sensor detects the position of the air mix damper and sends the appropriate signals to the A/C amplifier. The position sensor is built into the air mix damper control servomotor assembly.

DTC No.	Detection Item	Trouble Area
B1431	Short to ground or power source circuit in air mix damper position sensor circuit.	<ul style="list-style-type: none"> • Air mix damper position sensor. • Harness or connector between air mix damper control servomotor assembly and A/C amplifier. • A/C amplifier.

WIRING DIAGRAM

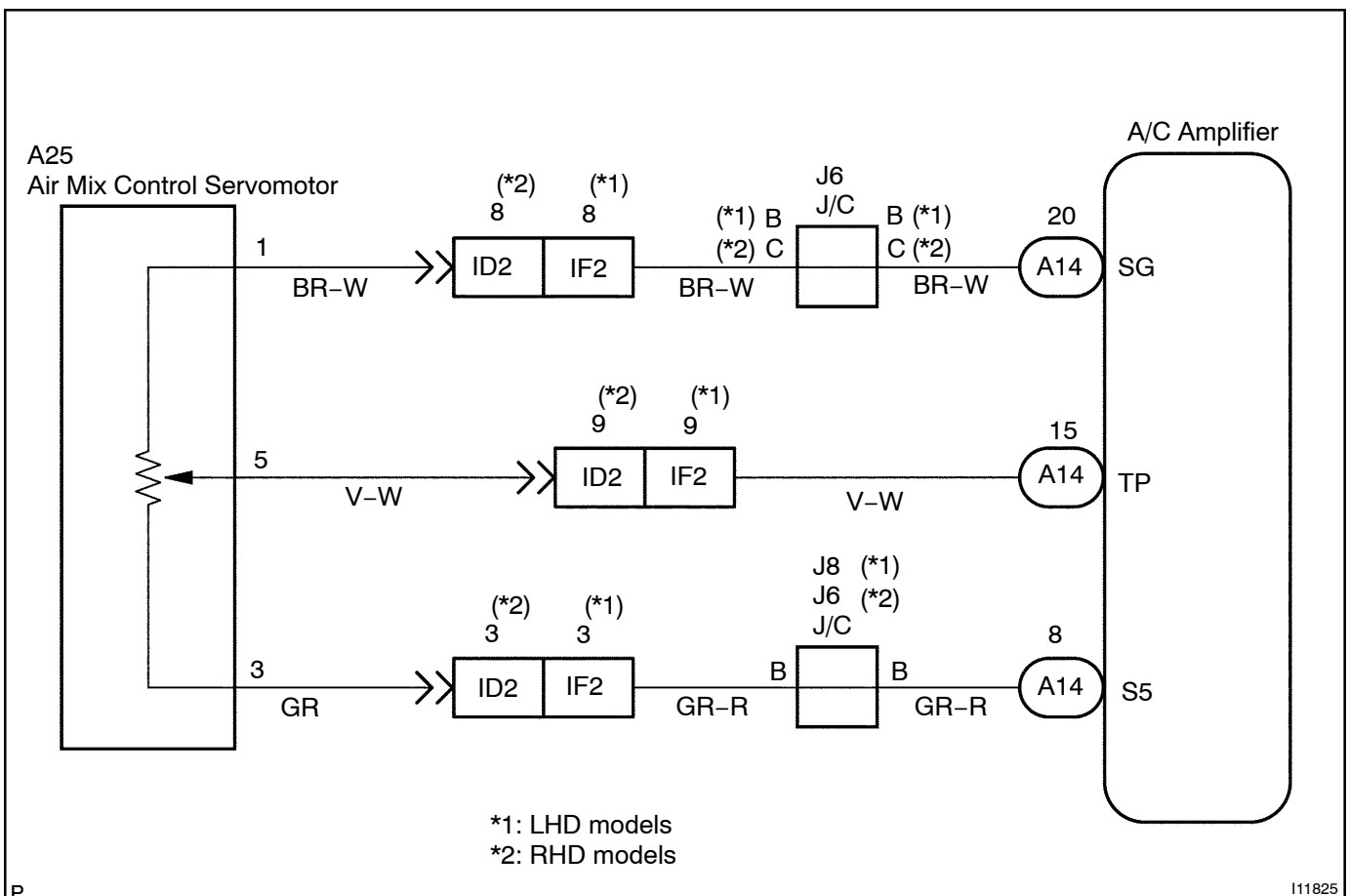

P

I11825

INSPECTION PROCEDURE

HINT:

In case of using the hand-held tester, start the inspection from step 1 and in case of not using the hand-held tester, start from step 2.

1 Check air mix damper position using hand-held tester.

PREPARATION:

Connect the hand-held tester to the DLC3.

CHECK:

Check the current position of air mix damper and the target position of air mix damper.

OK:

The current position and target position are almost similar.

OK Check and replace A/C amplifier.

NG

2 Check voltage between terminals TP and SG of A/C amplifier connector.

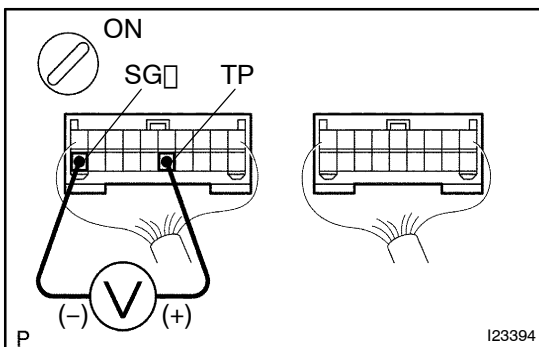

PREPARATION:

Remove A/C amplifier with connectors still connected.

CHECK:

- Turn ignition switch to ON.
- Change the set temperature to activate the air mix damper control servomotor, and measure the voltage between terminals TP and SG of A/C amplifier connector each time when the set temperature is changed.

OK:

Set Temperature	Voltage
Max. [cool]	3.5 - 4.5V
Max. [warm]	0.5 - 1.5V

HINT:

As the set temperature increases, the voltage decreases.

NG Go to step 3.

Ok

Proceed to next circuit inspection shown on problem symptoms table (See page DI-612). However, if DTC B1431 displayed, check and replace A/C amplifier.

3 Check air mix damper position sensor.

LHD Models:

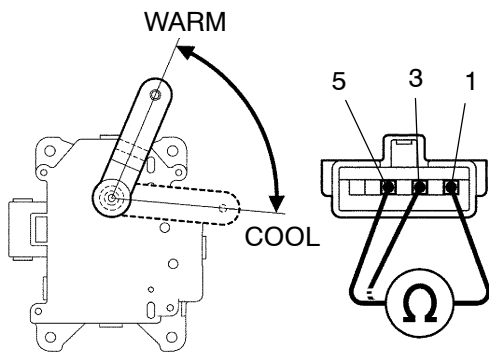

P

I23381

PREPARATION:

Remove the air mix damper control servomotor.

CHECK:

Measure resistance between terminals 1 and 3 of air mix damper control servomotor assembly connector.

OK:

Resistance: 4.2 - 7.8 kΩ

CHECK:

While operating air mix damper control servomotor, following the procedure on page DI-641, measure resistance between terminals 1 and 5 of air mix damper control servomotor assembly connector.

OK:

Position	Resistance
Max. Cool	3.6 - 6.8 kΩ
Max. Warm	0.5 - 1.1 kΩ

HINT:

As the air mix damper control servomotor moves from cool side to hot side, the resistance decreases.

RHD Models:

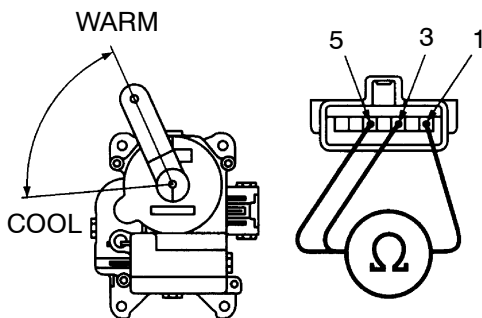

I05267

NG

Replace air mix damper control servomotor assembly.

OK

4 Check harness and connector between A/C amplifier and air mix damper control servomotor assembly (See page IN-34).

NG

Repair or replace harness or connector.

OK

Check and replace A/C amplifier.