

<b>DTC</b>	<b>B1443</b>	<b>Air Outlet Damper Control Servomotor Circuit</b>
------------	--------------	---

## CIRCUIT DESCRIPTION

This circuit turns the servomotor and changes each mode damper position by the signals from the A/C amplifier. When the AUTO switch is on, the A/C amplifier changes the mode automatically between (FACE), (BI-LEVEL) and (FOOT) according to the temperature setting.

DTC No.	Detection Item	Trouble Area
B1443	Air outlet damper position sensor value does not change even if A/C amplifier operated air outlet damper control servomotor.	<ul style="list-style-type: none"> <li>• Air outlet damper control servomotor.</li> <li>• Air outlet damper position sensor.</li> <li>• Harness or connector between A/C amplifier air outlet damper control servomotor, air outlet damper position sensor.</li> <li>• A/C amplifier.</li> </ul>

## WIRING DIAGRAM

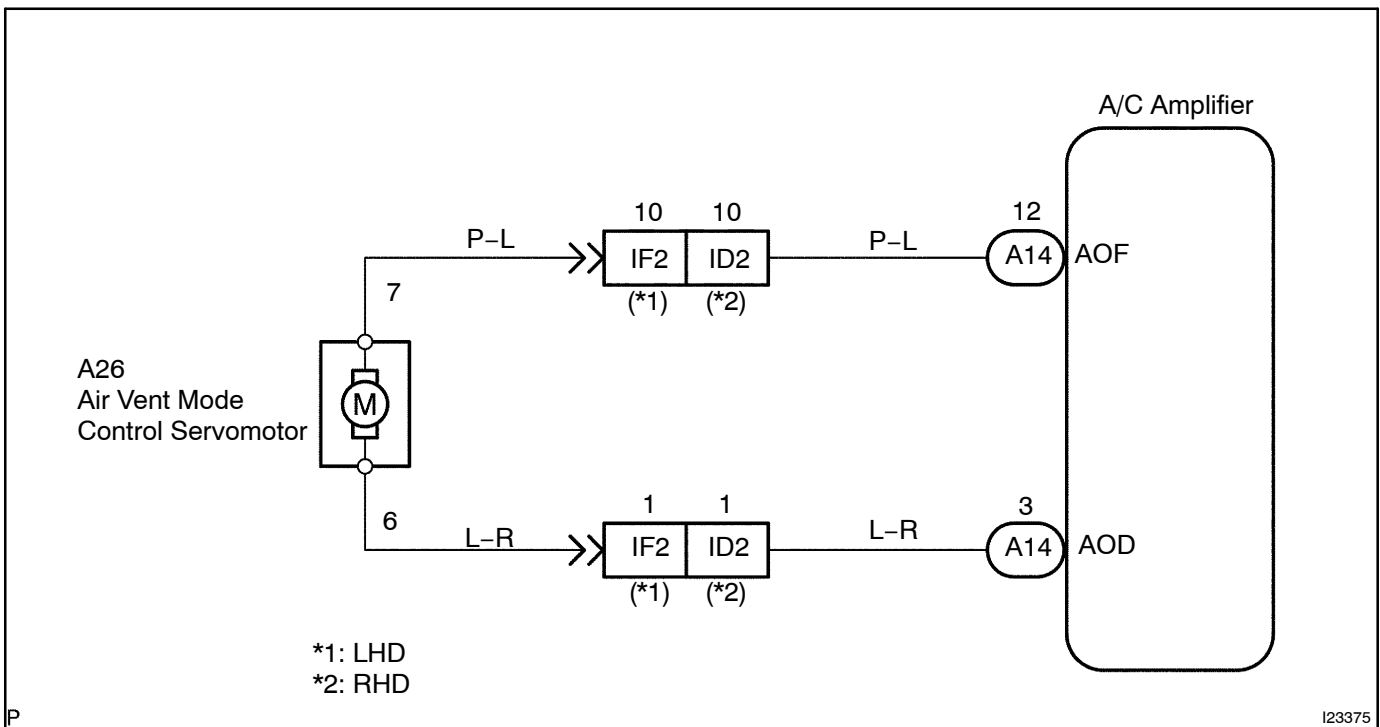

**INSPECTION PROCEDURE****1 Actuator check.****PREPARATION:**

Set to the actuator check mode (See page DI-606).

**CHECK:**

Check the condition of air flow.

**OK:**

Display Code	Air Flow
0 - 4	FACE
5	BI-LEVEL
6, 7	FOOT
8	FOOT DEF
9	DEF

**OK**

Proceed to next circuit inspection shown on problem symptoms table (See page DI-612).

**NG**

## 2 Check air outlet damper control servomotor.

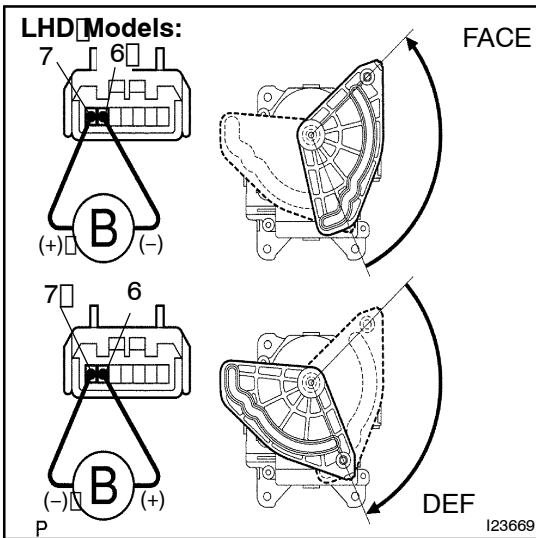

### PREPARATION:

Remove the air outlet damper control servomotor.

### CHECK:

Connect positive (+) lead to terminal 7 and negative (-) lead to terminal 6.

### OK:

The lever moves smoothly to FACE position.

### CHECK:

Connect positive (+) lead to terminal 6 and negative (-) lead to terminal 7.

### OK:

The lever moves smoothly to DEF position.

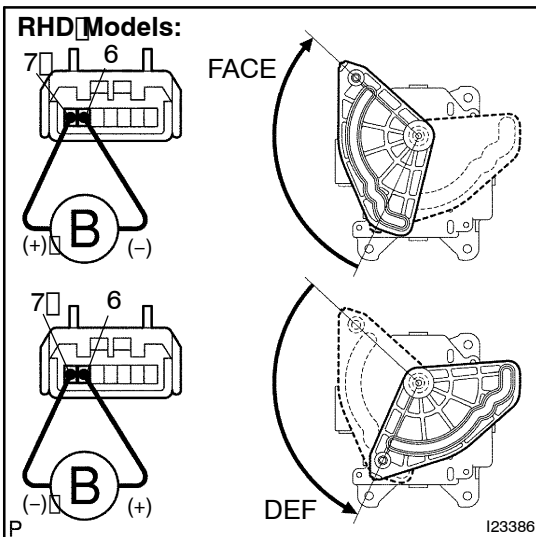

NG

Replace air outlet servomotor.

OK

## 3 Check harness and connector between A/C amplifier and air outlet damper control servomotor (See page IN-34).

NG

Repair or replace harness or connector.

OK

Check and replace A/C amplifier.