

# EVAPORATIVE EMISSION (EVAP) CONTROL SYSTEM INSPECTION

ECOKU-01

## 1. INSPECT LINES AND CONNECTORS

Visually check for loose connections, sharp bends or damage.

## 2. INSPECT FUEL TANK

Visually check for deformation, cracks or fuel leakage.

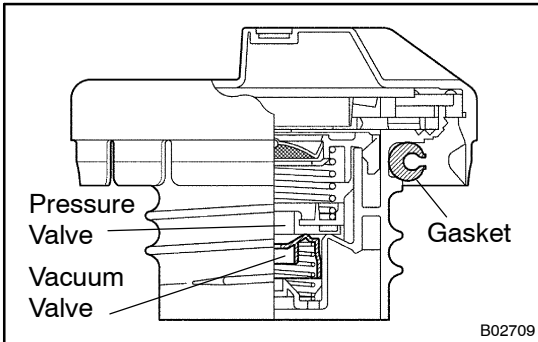

## 3. INSPECT FUEL TANK CAP

Visually check if the cap and/or gasket are deformed or damaged.

If necessary, repair or replace the cap.

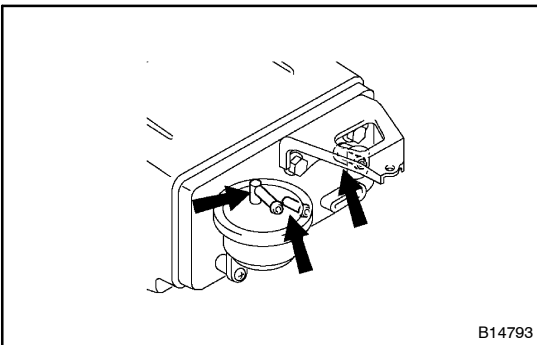

## 4. REMOVE CHARCOAL CANISTER

Disconnect the 2 hoses and pull up the canister.

## 5. INSPECT CHARCOAL CANISTER

(a) Visually check the charcoal canister for cracks or damage.

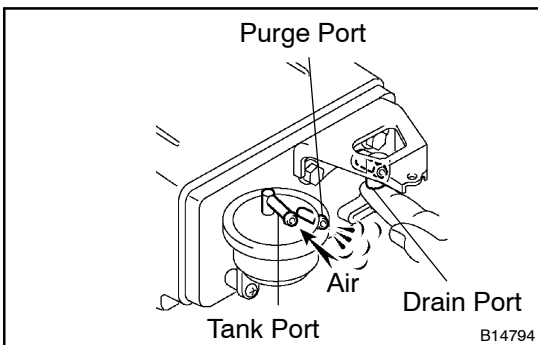

(b) Inspect the charcoal canister operation.

(1) While holding the drain port(s) closed, blow air (19.6 kPa, 0.2 kgf/cm<sup>2</sup>, 2.8 psi) into the tank port and check that air flows from the purge port.

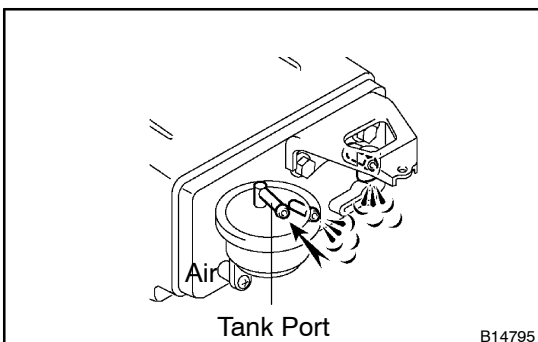

(2) Blow air (19.6 kPa, 0.2 kgf/cm<sup>2</sup>, 2.8 psi) into tank port and check that air flows without resistance from the other port.

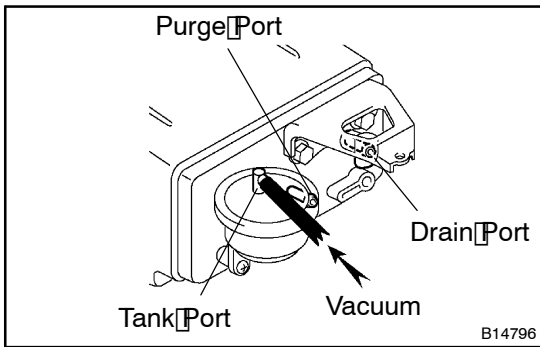

- (3) Apply vacuum (9.8 kPa, 73.5 mmHg, 2.9 in. Hg) to tank port and check that the vacuum gauge indicator with settle at about 2.0 kPa (15.0 mmHg, 0.6 in. Hg).

If operation is not as specified, replace the charcoal canister.

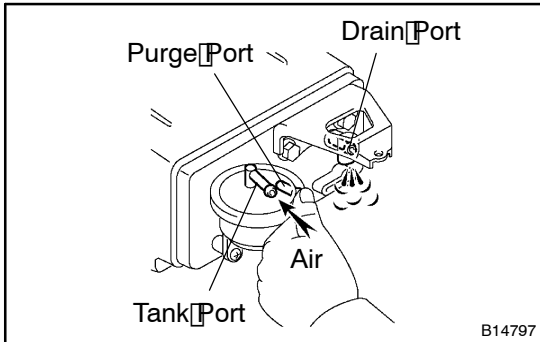

- (c) Clean the filter in the canister.

Clean the filter by blowing 294 kPa (3 kg/cm<sup>2</sup>, 43 psi) of compressed air into tank port while holding purge port closed.

**NOTICE:**

- Do not attempt to wash the canister.
- No activated carbon should come out.

**6. REINSTALL CHARCOAL CANISTER**

**7. REMOVE VSV FOR EVAP**

**8. INSPECT VSV FOR EVAP (See page FI-56)**

**9. REINSTALL VSV FOR EVAP**