

VALVE CLEARANCE ADJUSTMENT

EM02-06

HINT:

Inspect and adjust the valve clearance when the engine is cold.

1. REMOVE ENGINE COVER

Remove the 4 nuts and engine cover.

2. DRAIN ENGINE COOLANT

3. REMOVE INTAKE AIR RESONATOR

4. REMOVE THROTTLE BODY AND INTAKE AIR CONNECTOR ASSEMBLY

(a) Disconnect the accelerator cable from the throttle body.

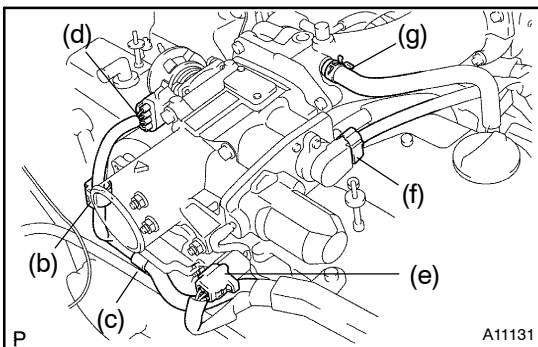

- (b) Disconnect the engine wire clamp from the clamp bracket of the throttle body.
- (c) Disconnect the engine wire from the clamp on the throttle body bracket.
- (d) Disconnect the accelerator pedal position sensor connector.
- (e) Disconnect the throttle control motor connector.
- (f) Disconnect the throttle position sensor connector.
- (g) Disconnect the air assist hose from the intake air connector.

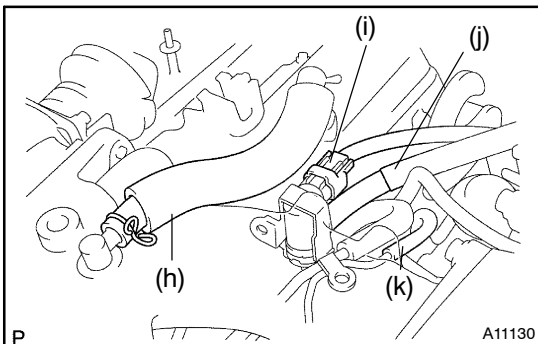

- (h) Disconnect the PCV hose from the intake air connector.
- (i) Disconnect the VSV connector for EVAP.
- (j) Disconnect the EVAP hose (from charcoal canister) from the VSV for EVAP.
- (k) Disconnect the vacuum hose (from No. 2 vacuum pipe) from the No. 1 vacuum pipe.

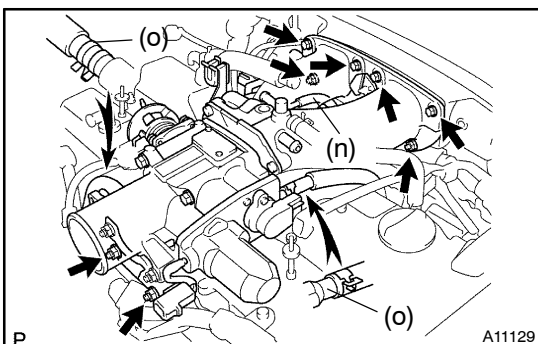

- (l) Remove the 2 nuts holding the throttle body bracket to the cylinder head.
- (m) Remove the 4 bolts and 2 nuts holding the intake air connector to the air intake chamber.
- (n) Disconnect the vacuum hose (from actuator for ACIS) from the No. 1 vacuum pipe.
- (o) Disconnect the 2 water bypass hoses from the throttle body, and remove the throttle body together with the intake air connector and gasket.

5. REMOVE NO. 3 TIMING BELT COVER

Using a 5 mm hexagon wrench, remove the 4 bolts, oil filler cap, timing belt cover and gasket.

6. REMOVE IGNITION COILS AND HIGH-TENSION CORD SET ASSEMBLY (See page G-6)**7. REMOVE SPARK PLUGS****8. DISCONNECT ENGINE WIRE FROM CYLINDER HEAD COVERS****9. REMOVE CYLINDER HEAD COVERS (See page EM-34)****10. SET NO. 1 CYLINDER TO TDC/COMPRESSION**

(a) Turn the crankshaft pulley and align its groove with the timing mark "0" of the No. 1 timing belt cover.

NOTICE:

Always turn the crankshaft clockwise.

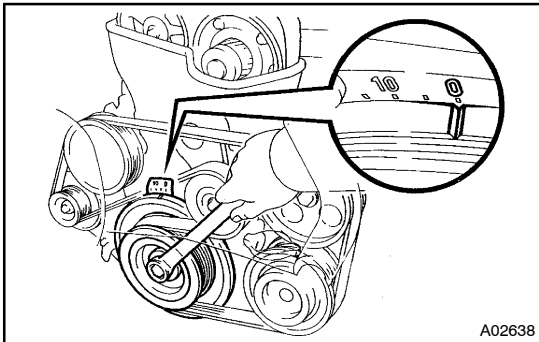

A02638

(b) Check that the timing marks of the camshaft timing pulleys are aligned with the timing marks of the No. 4 timing belt cover.

If not, turn the crankshaft 1 revolution (360°).

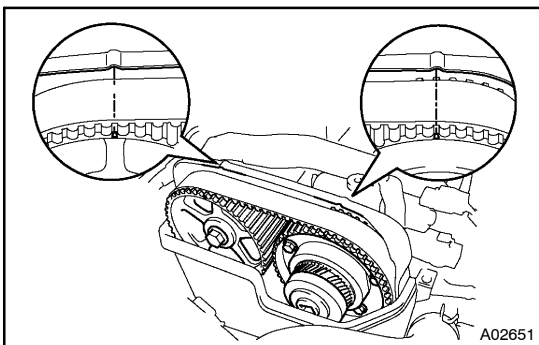

A02651

11. INSPECT VALVE CLEARANCE

(a) Check only those valves indicated in the illustration.

- Using a feeler gauge, measure the clearance between the valve lifter and camshaft.
- Record the valve clearance measurements of those that are out of specification. They will be used later to determine the required replacement adjusting shim.

Valve Clearance (Cold):

Intake	0.15 - 0.25 mm (0.006 - 0.010 in.)
Exhaust	0.25 - 0.35 mm (0.010 - 0.014 in.)

(b) Turn the crankshaft pulley 1 revolution (360°), and align the groove with the timing mark "0" of the No. 1 timing belt cover.

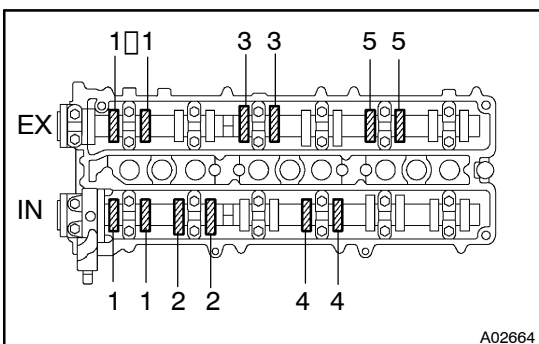

A02664

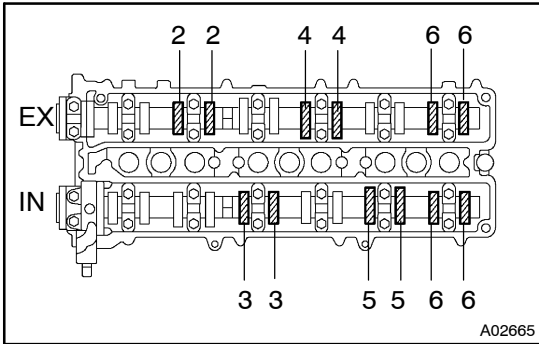

- (c) Check only the valves indicated as shown. Measure the valve clearance. (See procedure in step (a))

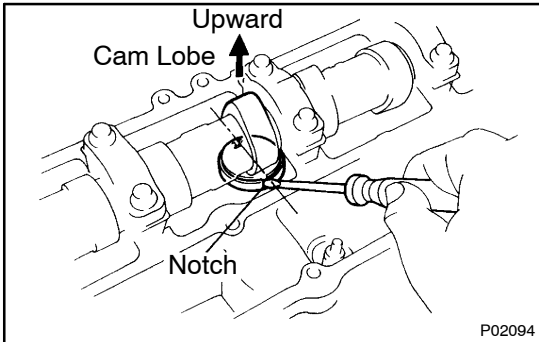

12. ADJUST VALVE CLEARANCE

- (a) Remove the adjusting shim.
- Turn the camshaft so that the cam lobe for the valve to be adjusted faces up.
 - Turn the valve lifter with a screwdriver so that the notches are perpendicular to the camshaft.

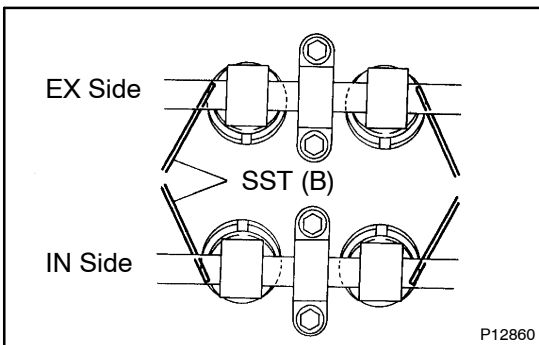

- Insert SST (B) gently from the inside as shown in the illustration.

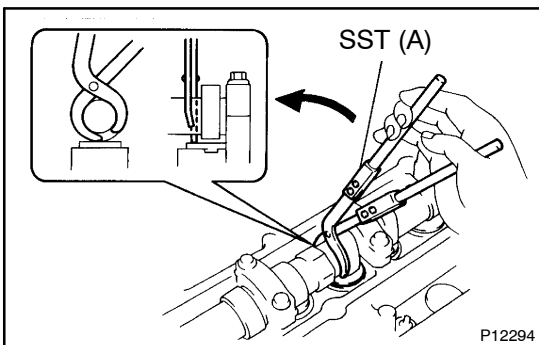

- Using SST (A), hold the camshaft as shown in the illustration.

SST 09248-55040 (09248-05410)

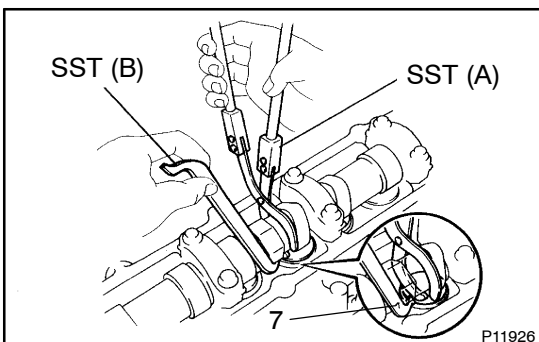

- Using SST (A), press down the valve lifter and place SST (B) between the camshaft and valve lifter. Remove SST (A).

SST 09248-55040 (09248-05410, 09248-05420)

HINT:

- Apply SST (B) at slight angle on the side marked with "7" or "9", at the position shown in the illustration.

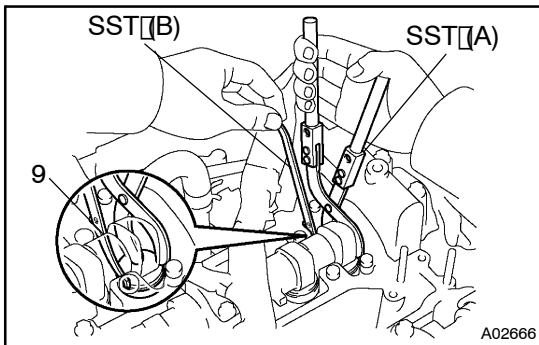

- When the adjusting shim of the No. 1 intake side is replaced, remove the No. 2 or No. 3 camshaft bearing cap, and insert SST as shown in the illustration.

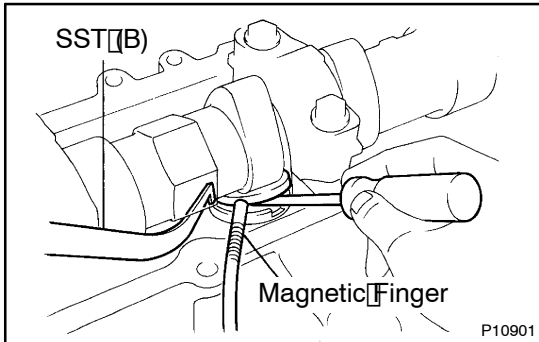

- Using a small screwdriver and a magnetic finger, remove the adjusting shim.

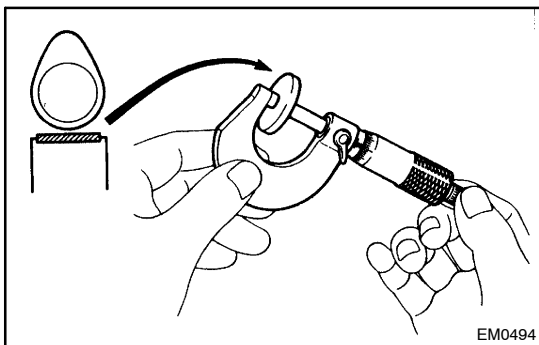

- (b) Determine the replacement adjusting shim size according to the following formula or Charts:

- Using a micrometer, measure the thickness of the removed shim.
 - Calculate the thickness of a new shim so the valve clearance comes within specified value.
- T..... Thickness of used shim
 A..... Measured valve clearance
 N..... Thickness of new shim

Intake

$$N = T + (A - 0.20 \text{ mm} (0.008 \text{ in.}))$$

Exhaust

$$N = T + (A - 0.30 \text{ mm} (0.012 \text{ in.}))$$

- Select a new shim with a thickness as close as possible to the calculated values.

HINT:

Shims are available in 17 sizes in increments of 0.050 mm (0.0020 in.), from 2.500 mm (0.0984 in.) to 3.300 mm (0.1299 in.).

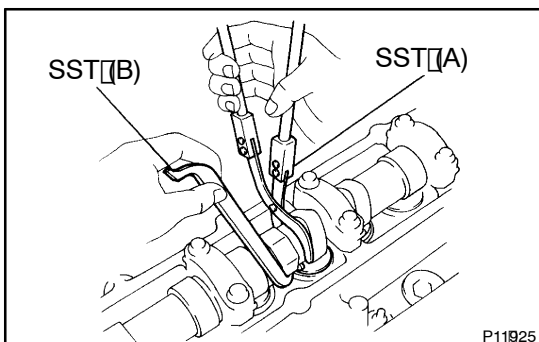

- (c) Install a new adjusting shim.
- Place a new adjusting shim on the valve lifter, with imprinted numbers facing down.
 - Press down the valve lifter with SST (A), and remove SST (B).

SST 09248-55040

13. REINSTALL CYLINDER HEAD COVERS

(See page EM-53)

14. RECONNECT ENGINE WIRE TO CYLINDER HEAD COVERS

15. REINSTALL SPARK PLUGS**16. REINSTALL IGNITION COILS AND HIGH-TENSION CORD SET ASSEMBLY (See page G-6)****17. REINSTALL NO. 3 TIMING BELT COVER**

- (a) Install the gasket to the timing belt cover.
- (b) Using a 5 mm hexagon wrench, install the timing belt cover with the 4 bolts.

Torque: 3.0 N·m (80 kgf·cm, 71 in·lbf)

- (c) Install the oil filler cap.

18. REINSTALL THROTTLE BODY AND INTAKE AIR CONNECTOR ASSEMBLY

- (a) Install a new gasket to the air intake chamber.
- (b) Place the throttle body together with the intake air connector on the cylinder head.
- (c) Connect the vacuum hose (from actuator for ACIS) to the No. 1 vacuum pipe.
- (d) Connect the 2 water bypass hoses to the throttle body.
- (e) Install the 4 bolts and 2 nuts holding the intake air connector to the air intake chamber.

Torque: 28 N·m (280 kgf·cm, 21 ft·lbf)

- (f) Install the 2 nuts holding the throttle body bracket to the cylinder head.

Torque: 21 N·m (210 kgf·cm, 15 ft·lbf)

- (g) Connect the air assist hose to the intake air connector.
- (h) Install the PCV hose to the intake air connector.
- (i) Install the EVAP hose (from charcoal canister) to the VSV for EVAP.
- (j) Install the vacuum hose (from No. 2 vacuum pipe) to the No. 1 vacuum pipe.
- (k) Install the throttle position sensor connector.
- (l) Install the accelerator pedal position sensor connector.
- (m) Install the throttle control motor connector.
- (n) Install the VSV connector for EVAP.
- (o) Secure the engine wire with the clamp on the throttle body bracket.
- (p) Install the engine wire clamp with the clamp bracket of the throttle body.
- (q) Connect the accelerator cable to the throttle body.

19. REINSTALL INTAKE AIR RESONATOR**20. REINSTALL ENGINE COVER**

Install the engine cover with the 4 nuts.

21. REFILL WITH ENGINE COOLANT**22. START ENGINE AND CHECK FOR LEAKS**

Adjusting Shim Selection Chart (Intake)

Measured Clearance mm (in.)	Installed Shim Thickness mm (in.)	2.500 (0.0984)	2.550 (0.1004)	2.600 (0.1024)	2.650 (0.1043)	2.700 (0.1063)	2.750 (0.1083)	2.800 (0.1102)	2.850 (0.1122)	2.900 (0.1142)	2.950 (0.1161)	3.000 (0.1181)	3.050 (0.1201)	3.100 (0.1220)	3.150 (0.1240)	3.200 (0.1260)	3.250 (0.1280)	3.300 (0.1299)
0.000 - 0.020 (0.0000 - 0.0008)	1	1	1	1	1	1	1	1	1	1	1	1	1	1	1	1	1	1
0.021 - 0.040 (0.0008 - 0.0016)	1	1	1	1	1	1	1	1	1	1	1	1	1	1	1	1	1	1
0.041 - 0.060 (0.0016 - 0.0024)	1	1	1	1	1	1	1	1	1	1	1	1	1	1	1	1	1	1
0.061 - 0.080 (0.0024 - 0.0031)	1	1	1	1	1	1	1	1	1	1	1	1	1	1	1	1	1	1
0.081 - 0.100 (0.0032 - 0.0039)	1	1	1	1	1	1	1	1	1	1	1	1	1	1	1	1	1	1
0.101 - 0.120 (0.0040 - 0.0047)	1	1	1	1	1	1	1	1	1	1	1	1	1	1	1	1	1	1
0.121 - 0.140 (0.0048 - 0.0055)	1	1	1	1	1	1	1	1	1	1	1	1	1	1	1	1	1	1
0.141 - 0.160 (0.0056 - 0.0063)	1	1	1	1	1	1	1	1	1	1	1	1	1	1	1	1	1	1
0.161 - 0.180 (0.0064 - 0.0071)	1	1	1	1	1	1	1	1	1	1	1	1	1	1	1	1	1	1
0.181 - 0.200 (0.0072 - 0.0079)	1	1	1	1	1	1	1	1	1	1	1	1	1	1	1	1	1	1
0.201 - 0.220 (0.0080 - 0.0087)	1	1	1	1	1	1	1	1	1	1	1	1	1	1	1	1	1	1
0.221 - 0.240 (0.0088 - 0.0095)	1	1	1	1	1	1	1	1	1	1	1	1	1	1	1	1	1	1
0.241 - 0.260 (0.0096 - 0.0103)	1	1	1	1	1	1	1	1	1	1	1	1	1	1	1	1	1	1
0.261 - 0.280 (0.0104 - 0.0111)	1	1	1	1	1	1	1	1	1	1	1	1	1	1	1	1	1	1
0.281 - 0.300 (0.0112 - 0.0119)	1	1	1	1	1	1	1	1	1	1	1	1	1	1	1	1	1	1
0.301 - 0.320 (0.0120 - 0.0127)	1	1	1	1	1	1	1	1	1	1	1	1	1	1	1	1	1	1
0.321 - 0.340 (0.0128 - 0.0135)	1	1	1	1	1	1	1	1	1	1	1	1	1	1	1	1	1	1
0.341 - 0.360 (0.0136 - 0.0143)	1	1	1	1	1	1	1	1	1	1	1	1	1	1	1	1	1	1
0.361 - 0.380 (0.0144 - 0.0151)	1	1	1	1	1	1	1	1	1	1	1	1	1	1	1	1	1	1
0.381 - 0.400 (0.0152 - 0.0159)	1	1	1	1	1	1	1	1	1	1	1	1	1	1	1	1	1	1
0.401 - 0.420 (0.0160 - 0.0167)	1	1	1	1	1	1	1	1	1	1	1	1	1	1	1	1	1	1
0.421 - 0.440 (0.0168 - 0.0175)	1	1	1	1	1	1	1	1	1	1	1	1	1	1	1	1	1	1
0.441 - 0.460 (0.0176 - 0.0183)	1	1	1	1	1	1	1	1	1	1	1	1	1	1	1	1	1	1
0.461 - 0.480 (0.0184 - 0.0191)	1	1	1	1	1	1	1	1	1	1	1	1	1	1	1	1	1	1
0.481 - 0.500 (0.0192 - 0.0199)	1	1	1	1	1	1	1	1	1	1	1	1	1	1	1	1	1	1
0.501 - 0.520 (0.0200 - 0.0207)	1	1	1	1	1	1	1	1	1	1	1	1	1	1	1	1	1	1
0.521 - 0.540 (0.0208 - 0.0215)	1	1	1	1	1	1	1	1	1	1	1	1	1	1	1	1	1	1
0.541 - 0.560 (0.0216 - 0.0223)	1	1	1	1	1	1	1	1	1	1	1	1	1	1	1	1	1	1
0.561 - 0.580 (0.0224 - 0.0231)	1	1	1	1	1	1	1	1	1	1	1	1	1	1	1	1	1	1
0.581 - 0.600 (0.0232 - 0.0239)	1	1	1	1	1	1	1	1	1	1	1	1	1	1	1	1	1	1
0.601 - 0.620 (0.0240 - 0.0247)	1	1	1	1	1	1	1	1	1	1	1	1	1	1	1	1	1	1
0.621 - 0.640 (0.0248 - 0.0255)	1	1	1	1	1	1	1	1	1	1	1	1	1	1	1	1	1	1
0.641 - 0.660 (0.0256 - 0.0263)	1	1	1	1	1	1	1	1	1	1	1	1	1	1	1	1	1	1
0.661 - 0.680 (0.0264 - 0.0271)	1	1	1	1	1	1	1	1	1	1	1	1	1	1	1	1	1	1
0.681 - 0.700 (0.0272 - 0.0279)	1	1	1	1	1	1	1	1	1	1	1	1	1	1	1	1	1	1
0.701 - 0.720 (0.0280 - 0.0287)	1	1	1	1	1	1	1	1	1	1	1	1	1	1	1	1	1	1
0.721 - 0.740 (0.0288 - 0.0295)	1	1	1	1	1	1	1	1	1	1	1	1	1	1	1	1	1	1
0.741 - 0.760 (0.0296 - 0.0303)	1	1	1	1	1	1	1	1	1	1	1	1	1	1	1	1	1	1
0.761 - 0.780 (0.0304 - 0.0311)	1	1	1	1	1	1	1	1	1	1	1	1	1	1	1	1	1	1
0.781 - 0.800 (0.0312 - 0.0319)	1	1	1	1	1	1	1	1	1	1	1	1	1	1	1	1	1	1
0.801 - 0.820 (0.0320 - 0.0327)	1	1	1	1	1	1	1	1	1	1	1	1	1	1	1	1	1	1
0.821 - 0.840 (0.0328 - 0.0335)	1	1	1	1	1	1	1	1	1	1	1	1	1	1	1	1	1	1
0.841 - 0.860 (0.0336 - 0.0343)	1	1	1	1	1	1	1	1	1	1	1	1	1	1	1	1	1	1
0.861 - 0.880 (0.0344 - 0.0351)	1	1	1	1	1	1	1	1	1	1	1	1	1	1	1	1	1	1
0.881 - 0.900 (0.0352 - 0.0359)	1	1	1	1	1	1	1	1	1	1	1	1	1	1	1	1	1	1
0.901 - 0.920 (0.0360 - 0.0367)	1	1	1	1	1	1	1	1	1	1	1	1	1	1	1	1	1	1
0.921 - 0.940 (0.0368 - 0.0375)	1	1	1	1	1	1	1	1	1	1	1	1	1	1	1	1	1	1
0.941 - 0.960 (0.0376 - 0.0383)	1	1	1	1	1	1	1	1	1	1	1	1	1	1	1	1	1	1
0.961 - 0.980 (0.0384 - 0.0391)	1	1	1	1	1	1	1	1	1	1	1	1	1	1	1	1	1	1
0.981 - 1.000 (0.0392 - 0.0400)	1	1	1	1	1	1	1	1	1	1	1	1	1	1	1	1	1	1
1.001 - 1.020 (0.0401 - 0.0410)	1	1	1	1	1	1	1	1	1	1	1	1	1	1	1	1	1	1
1.021 - 1.040 (0.0411 - 0.0420)	1	1	1	1	1	1	1	1	1	1	1	1	1	1	1	1	1	1
1.041 - 1.060 (0.0421 - 0.0430)	1	1	1	1	1	1	1	1	1	1	1	1	1	1	1	1	1	1

New shim thickness mm (in.)

Shim No.	Thickness	Shim No.	Thickness
1	2.500 (0.0984)	10	2.950 (0.1161)
2	2.550 (0.1004)	11	3.000 (0.1181)
3	2.600 (0.1024)	12	3.050 (0.1201)
4	2.650 (0.1043)	13	3.100 (0.1220)
5	2.700 (0.1063)	14	3.150 (0.1240)
6	2.750 (0.1083)	15	3.200 (0.1260)
7	2.800 (0.1102)	16	3.250 (0.1280)
8	2.850 (0.1122)	17	3.300 (0.1299)
9	2.900 (0.1142)		

HINT: New shims have the thickness in millimeters imprinted on the face.

Intake valve clearance (Cold): 0.15 - 0.25 mm (0.006 - 0.010 in.)

EXAMPLE: The 2.800 mm (0.1102 in.) shim is installed, and the measured clearance is 0.450 mm (0.0177 in.). Replace the 2.800 mm (0.1102 in.) shim with a new No. 12 shim.

