

DISASSEMBLY

1. REMOVE WATER OUTLET WITH WATER BYPASS HOSE

Remove the 2 nuts, bolt, water outlet and gasket.

2. REMOVE ENGINE HANGER

3. REMOVE CAMSHAFT POSITION SENSOR

4. REMOVE ECT SENSOR

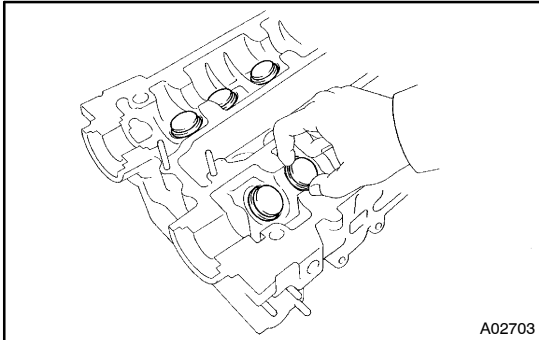

5. REMOVE VALVE LIFTERS AND SHIMS

HINT:

Store the valve lifters and shims in correct order.

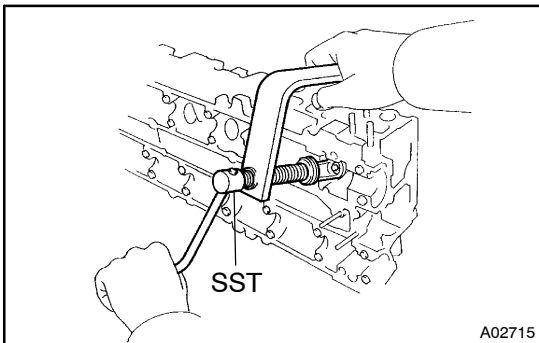

6. REMOVE VALVES

- (a) Using SST, compress the valve spring and remove the 2 keepers.

SST 09202-70020 (09202-00010)

- (b) Remove the spring retainer, valve spring, valve and spring seat.

HINT:

Store the valves, valve springs, spring seats and spring retainers in correct order.

- (c) Using needle-nose pliers, remove the oil seal.