

REASSEMBLY

HINT:

- Thoroughly clean all parts to be assembled.
- Before installing the parts, apply fresh engine oil to all sliding and rotating surfaces.
- Replace all gaskets and oil seals with new ones.

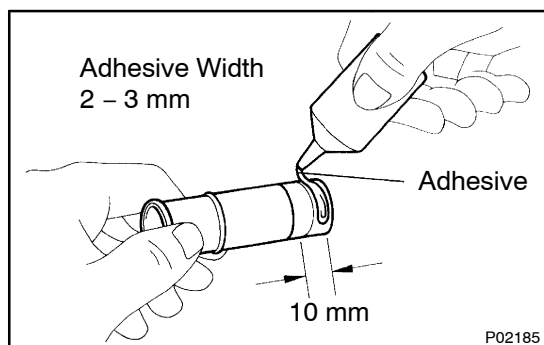

1. INSTALL HEATER UNION

HINT:

When using a new cylinder head, a new heater union must be installed.

- (a) Apply adhesive to the end of the heater union as shown in the illustration.

Adhesive: Part No.08833-00070, THREE BOND 1324 or equivalent

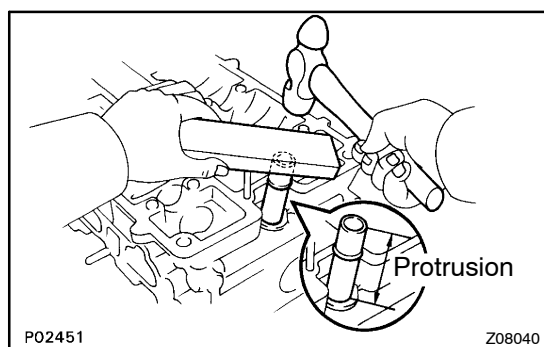

- (b) Using a wooden block and hammer, tap in a new heater union, leaving 48 mm (1.89 in.) protruding from the cylinder head.

NOTICE:

Do not tap it in too far.

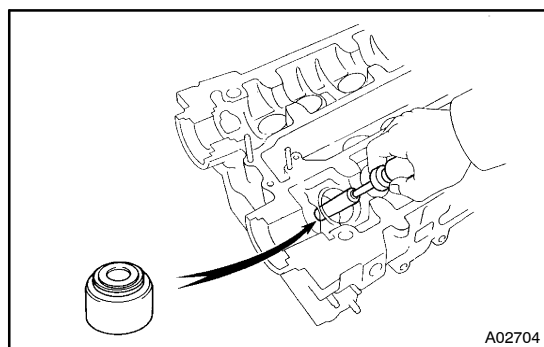

2. INSTALL VALVES

- (a) Install a new oil seal on the valve guide bushing.

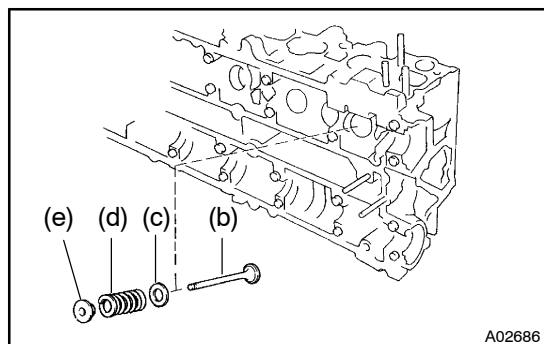

- (b) Install the valve.
 (c) Install the spring seat.
 (d) Install the valve spring.
 (e) Install the spring retainer.

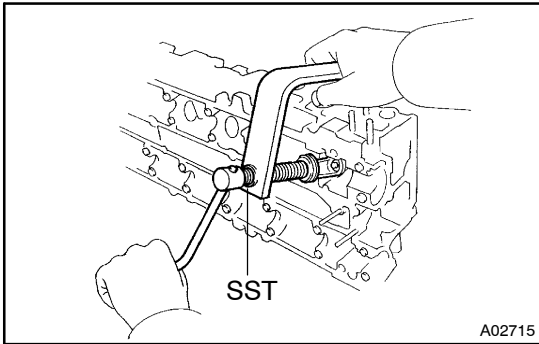

- (f) Using SST, compress the valve spring and place the 2 keepers around the valve stem.
SST 09202-70020 (09202-00010)

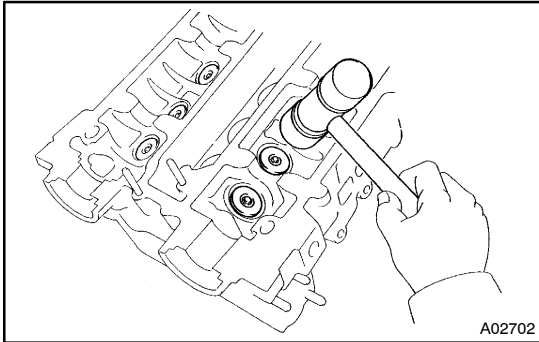

- (g) Using a plastic-faced hammer, lightly tap the valve stem tip to assure proper fit.

3. INSTALL VALVE LIFTERS AND SHIMS

- (a) Install the valve lifter and shim.
(b) Check that the valve lifter rotates smoothly by hand.

4. INSTALL ECT SENSOR

Torque: 19.6 N·m (200 kgf·cm, 14 ft·lbf)

5. INSTALL CAMSHAFT POSITION SENSOR

6. INSTALL ENGINE HANGER

Torque: 40 N·m (400 kgf·cm, 30 ft·lbf)

7. INSTALL WATER OUTLET WITH WATER BYPASS HOSE

Install a new gasket and the water outlet with the bolt and 2 nuts.

Torque: 28 N·m (280 kgf·cm, 21 ft·lbf)