

REPLACEMENT

1. REPLACE CONNECTING ROD BUSHING

- (a) Using SST and a press, press out the bushing.
SST 09222-30010

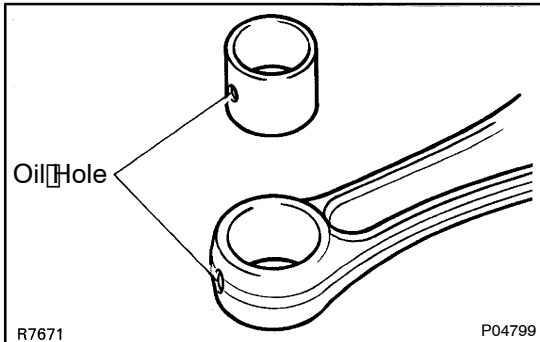

- (b) Align the oil holes of a new bushing and the connecting rod.

- (c) Using SST and a press, press in the bushing.
SST 09222-30010

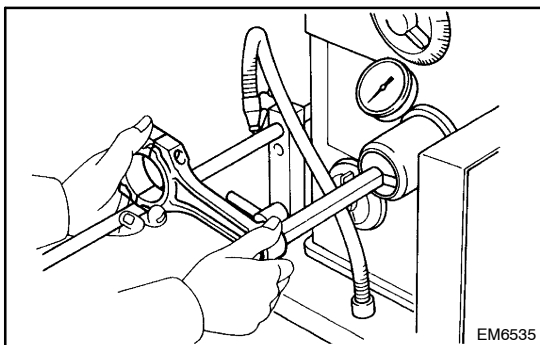

- (d) Using a pin hole grinder, bore the bushing to obtain the standard specified clearance (See page EM-85) between the bushing and piston pin.

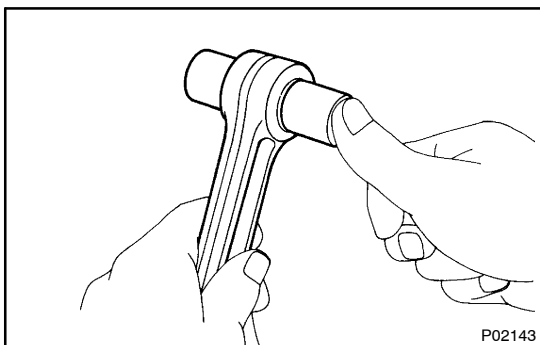

- (e) Check the piston pin fit at room temperature. Coat the piston pin with engine oil and push it into the connecting rod with your thumb.

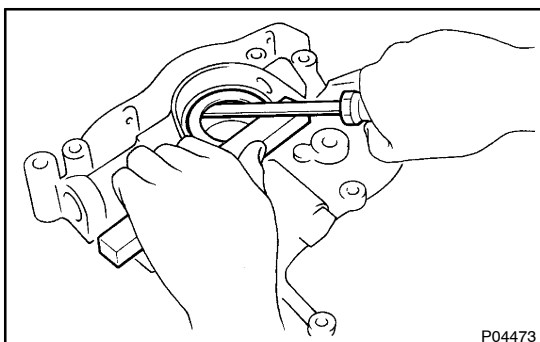

2. REPLACE CRANKSHAFT FRONT OIL SEAL

HINT:

There are 2 methods (a) and (b) to replace the oil seal as follows:

- (a) If the oil pump is removed from the cylinder block.
(1) Using a screwdriver, pry out the oil seal.

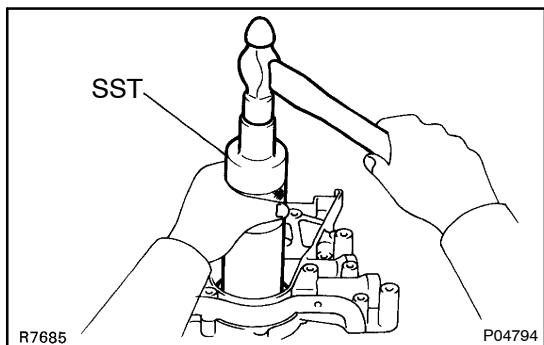

- (2) Using SST and a hammer, tap in a new oil seal until its surface is flush with the oil pump body edge.

SST 09316-60011 (09316-00011)

- (3) Apply MP grease to the oil seal lip.

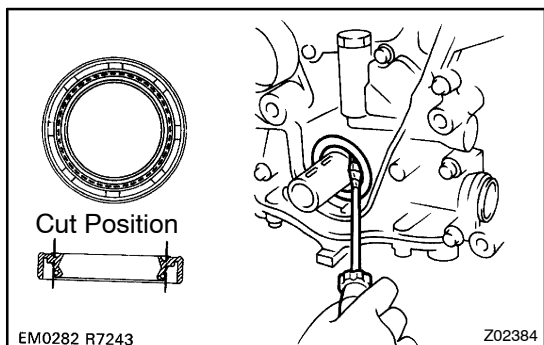

- (b) If the pump is installed on the cylinder block.
 - (1) Using a knife, cut off the oil seal lip.
 - (2) Using a screwdriver, pry out the oil seal.

NOTICE:

Be careful not to damage the crankshaft. Tape the screwdriver tip.

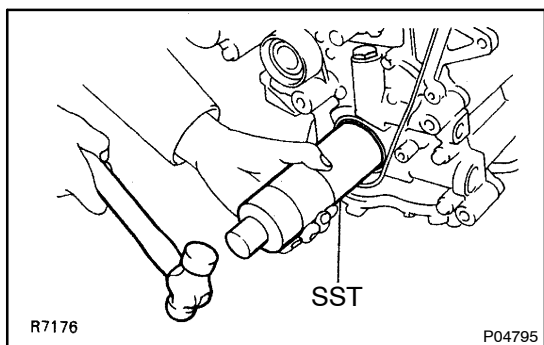

- (3) Apply MP grease to a new oil seal lip.

- (4) Using SST and a hammer, tap in the oil seal until its surface is flush with the oil pump body edge.

SST 09316-60011 (09316-00011)

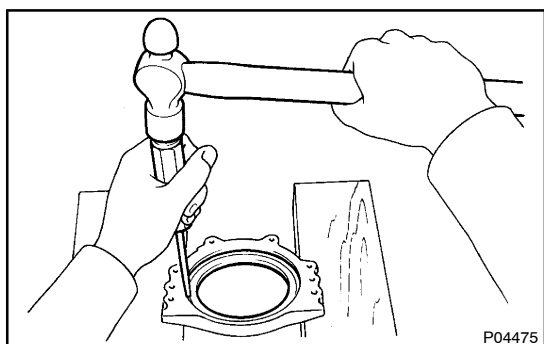

3. REPLACE CRANKSHAFT REAR OIL SEAL

HINT:

There are 2 methods (a) and (b) to replace the oil seal as follows:

- (a) If the rear oil seal retainer is removed from the cylinder block.

- (1) Using a screwdriver and hammer, tap out the oil seal.

- (2) Using SST and a hammer, tap in a new oil seal until its surface is flush with the rear oil seal retainer edge.

SST 09223-15030, 09950-70010 (09951-07100)

- (3) Apply MP grease to the oil seal lip.

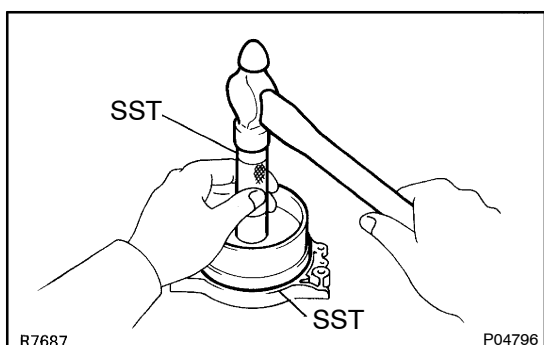

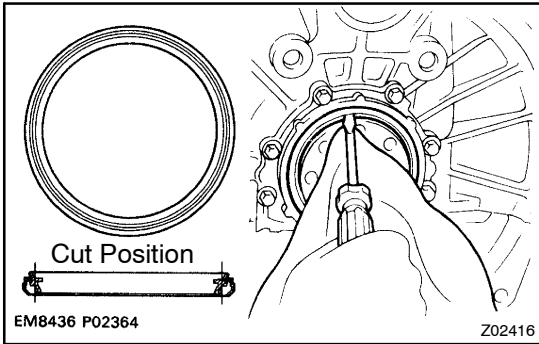

- (b) If the rear seal retainer is installed on the cylinder block.
- (1) Using a knife, cut off the oil seal lip.
 - (2) Using a screwdriver, pry out the oil seal.

NOTICE:

Be careful not to damage the crankshaft. Tape the screwdriver tip.

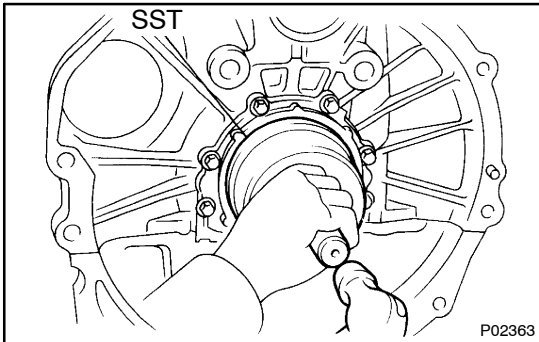

- (3) Apply MP grease to a new oil seal lip.
 - (4) Using SST and a hammer, tap in the oil seal until its surface is flush with the rear oil seal retainer edge.
- SST 09223-15030, 09950-70010 (09951-07100)