

REASSEMBLY

HINT:

- Thoroughly clean all parts to be assembled.
- Before installing the parts, apply fresh engine oil to all sliding and rotating surfaces.
- Replace all gaskets, O-rings and oil seals with new parts.

NOTICE:

Apply a generous amount of oil on the sliding surface of the bearing, and not on the back of it or on the surface to which it is installed.

1. ASSEMBLE PISTON AND CONNECTING ROD

- (a) Using a small screwdriver, install a new snap ring on one side of the piston pin hole.

HINT:

Be sure that end gap of the snap ring is not aligned with the pin hole cutout portion of the piston.

- (b) Gradually heat the piston to about 80°C (176°F).

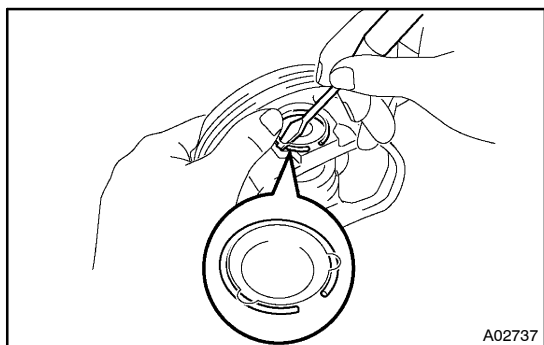

A02737

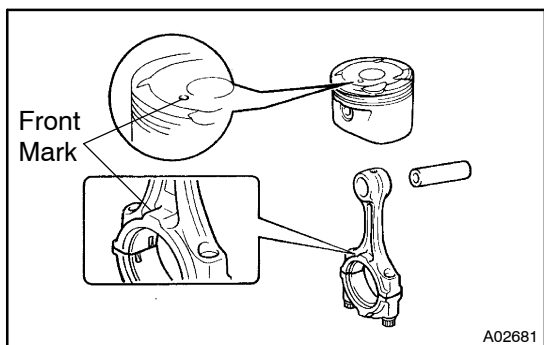

A02681

- (c) Coat the piston pin with engine oil.
 (d) Align the front marks of the piston and connecting rod, and push in the piston pin with your thumb.
 (e) Install a new snap ring at the other end of the piston pin hole.

HINT:

Be sure that end gap of the snap ring is not aligned with the pin hole cutout portion of the piston.

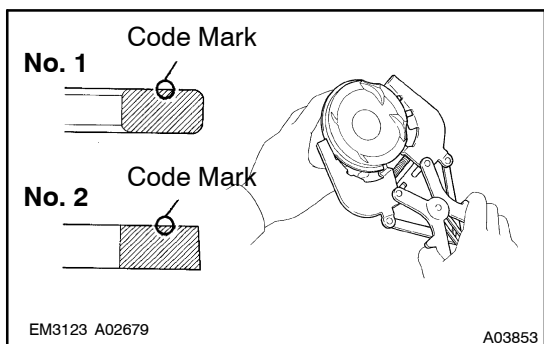

EM3123 A02679

A03853

2. INSTALL PISTON RINGS

- (a) Install the oil ring expander and 2 side rails by hand.
 (b) Using a piston ring expander, install the 2 compression rings with the code mark facing up.

Code mark:

No. 1	1T
No. 2	2T

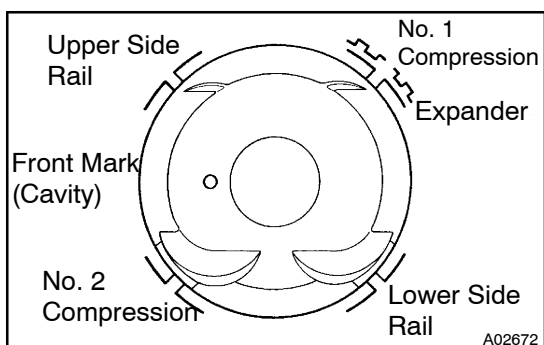

A02672

- (c) Position the piston rings so that the ring ends are as shown.

NOTICE:

Do not align the piston ring ends.

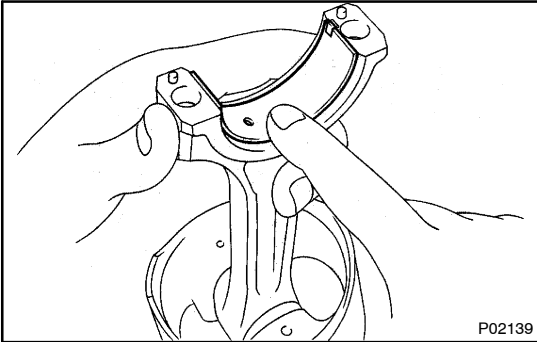

3. INSTALL BEARINGS

- (a) Align the bearing claw with the groove of the connecting rod and connecting cap.
- (b) Install the bearings in the connecting rod and connecting rod cap.

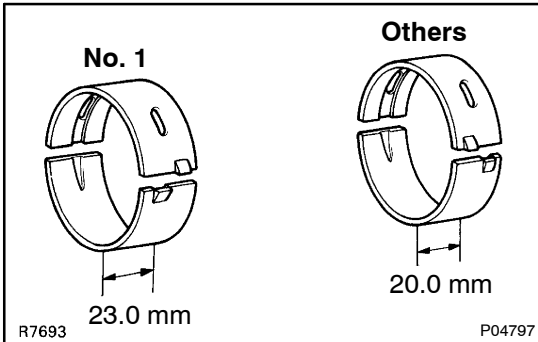

4. INSTALL MAIN BEARINGS

HINT:

- Main bearings come in widths of 20.0 mm (0.787 in.) and 23.0 mm (0.906 in.). Install the 23.0 mm bearings in the No.1 cylinder block journal position with the main bearing cap. Install the 20.0 mm bearings in the other positions.
- Upper bearings have an oil groove and oil holes; lower bearings do not.

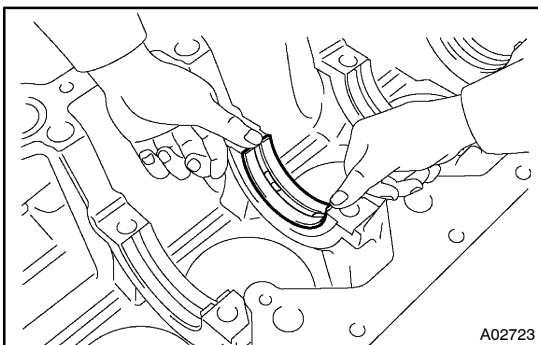

- (a) Align the bearing claw with the claw groove of the main bearing cap or cylinder block.

NOTICE:

Install the bearing with the oil hole in the cylinder block.

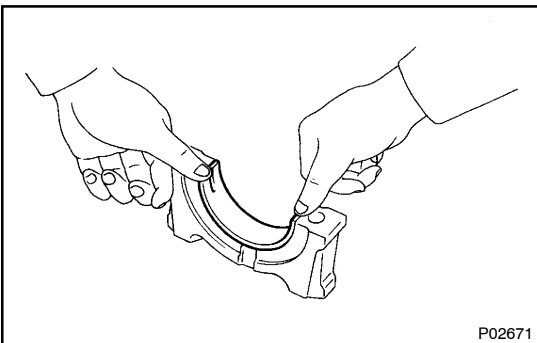

- (b) Install the bearings in the cylinder block and main bearing caps.

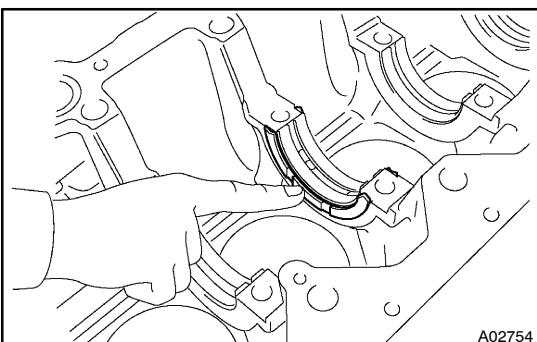

5. INSTALL UPPER THRUST WASHERS

Install the 2 thrust washers under the No.4 main journal position of the cylinder block with the oil grooves facing outward.

6. PLACE CRANKSHAFT ON CYLINDER BLOCK

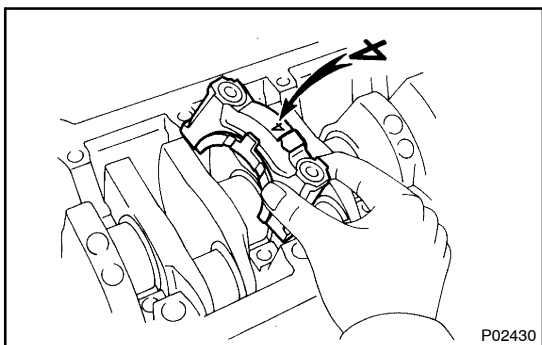

7. PLACE MAIN BEARING CAP AND LOWER THRUST WASHERS ON CYLINDER BLOCK

- (a) Install the lower thrust washers on the No. 4 main bearing with the grooves facing outward.

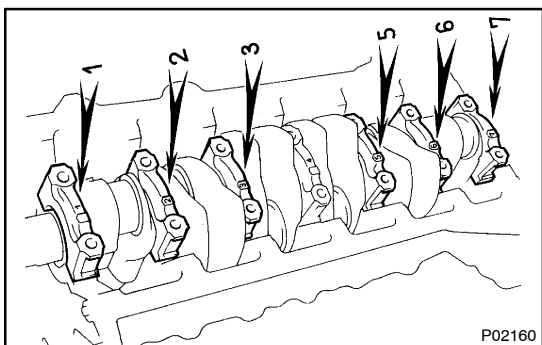

- (b) Install the main bearing caps in numerical order with the arrows facing forward.

8. INSTALL MAIN BEARING CAP BOLTS

HINT:

- The main bearing cap bolts are tightened in 2 progressive steps (steps (b) and (d)).
- If any of the main bearing bolts break or deform, replace them.

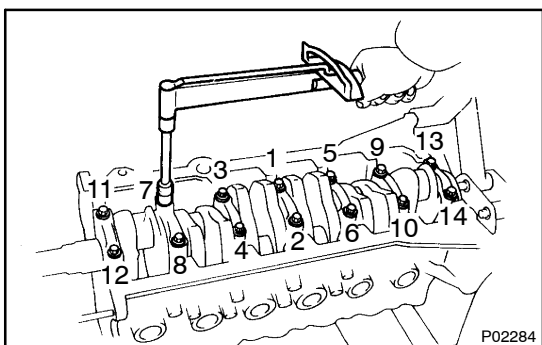

- (a) Apply a light coat of engine oil on the threads and under the heads of the main bearing cap bolts.
- (b) Install and uniformly tighten the 14 main bearing cap bolts, in several passes, in the sequence shown.

Torque: 45 N·m (450 kgf·cm, 33 ft·lbf)

If any one of the main bearing cap bolts does not meet the torque specification, replace the main bearing cap bolt.

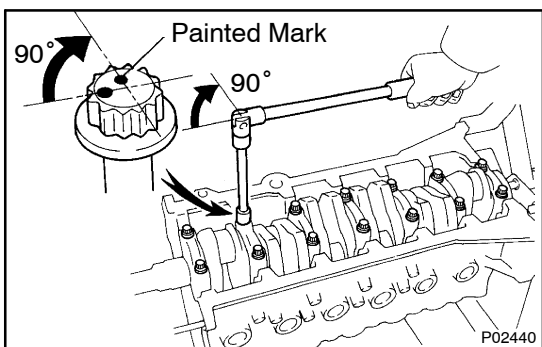

- (c) Mark the front of the main bearing cap bolt head with paint.
- (d) Retighten the main bearing cap bolts 90° in the numerical order shown above.
- (e) Check that the painted mark is now at a 90° angle to the front.
- (f) Check that the crankshaft turns smoothly.

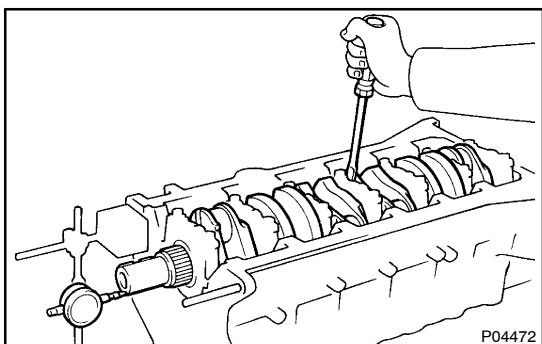

9. CHECK CRANKSHAFT THRUST CLEARANCE

Using a dial indicator, measure the thrust clearance while prying the crankshaft back and forth with a screwdriver.

Standard thrust clearance:

0.020 - 0.220 mm (0.0008 - 0.0087 in.)

Maximum thrust clearance:

0.30 mm (0.0118 in.)

If the thrust clearance is greater than maximum, replace the thrust washers as a set.

Thrust washer thickness:

1.940 – 1.990 mm (0.0764 – 0.0783 in.)

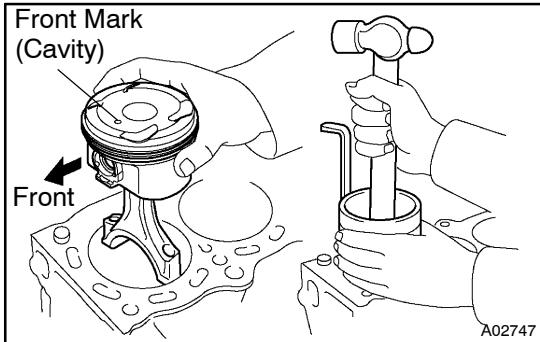

10. INSTALL PISTON AND CONNECTING ROD ASSEMBLIES

Using a piston ring compressor, push the correctly numbered piston and connecting rod assemblies into each cylinder with the front mark of the piston facing forward.

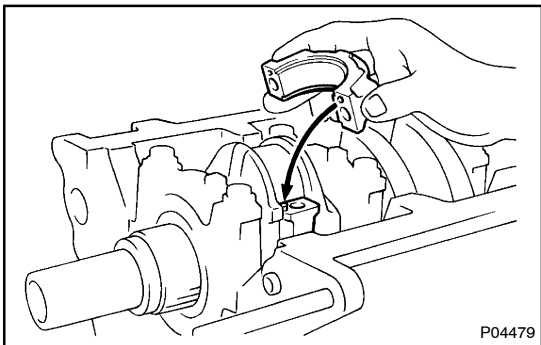

11. PLACE CONNECTING ROD CAP ON CONNECTING ROD

- (a) Match the numbered connecting rod cap with the connecting rod.
- (b) Install the connecting rod cap with by aligning the dowel pin to the corresponding hole.

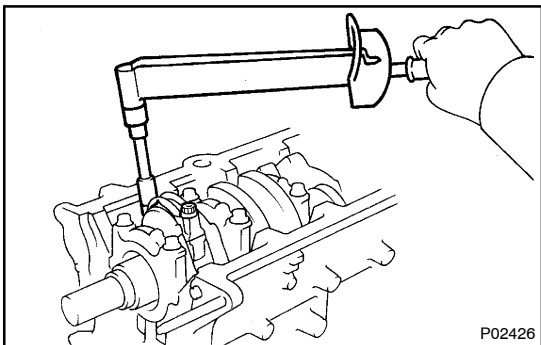

12. INSTALL CONNECTING ROD CAP BOLTS

HINT:

- The connecting rod cap bolts are tightened in 2 progressive steps (steps (b) and (d)).
 - If any of the connecting rod bolts break or deform, replace them.
- (a) Apply a light coat of engine oil on the threads and under the heads of the connecting rod cap bolts.
 - (b) Install and alternately tighten the bolts of the connecting rod cap in several passes.

Torque: 30 N·m (300 kgf·cm, 22 ft·lbf)

If any one of the connecting rod cap bolts does not meet the torque specification, replace the cap bolt.

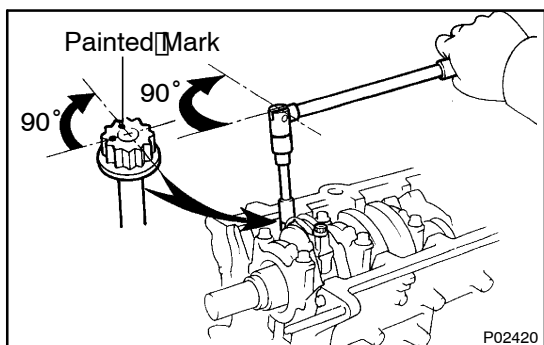

- (c) Mark the front of the connecting rod cap bolt with paint.
- (d) Retighten the connecting rod cap bolts 90° in the numerical order shown.
- (e) Check that the painted mark shows at a 90° angle to the front.
- (f) Check that the crankshaft turns smoothly.

13. CHECK CONNECTING ROD THRUST CLEARANCE (See page EM-78)

14. INSTALL REAR OIL SEAL RETAINER

- (a) Remove any old packing (FIPG) material and be careful not to drop any oil on the contact surfaces of the retainer and cylinder block.
 - Using a razor blade and gasket scraper, remove all the old packing (FIPG) material from the gasket surfaces and sealing groove.
 - Thoroughly clean all components to remove all debris.
 - Using a non-residue solvent, clean both sealing surfaces.

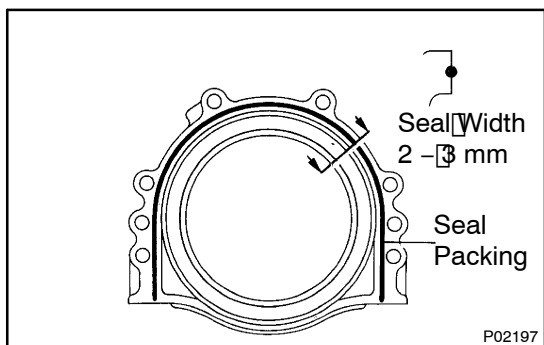

- (b) Apply seal packing to the retainer as shown in the illustration.

Seal packing: Part No.08826-00080 or equivalent

- Install a nozzle that has been cut to a 2-3 mm (0.08-0.12 in.) opening.
 - Parts must be assembled within 3 minutes of application. Otherwise the material must be removed and reapplied.
 - Immediately remove nozzle from the tube and reinstall cap.
- (c) Install the retainer with the 6 bolts.
Torque: 6.0 N·m (60 kgf·cm, 53 in·lbf)

15. INSTALL OIL PUMP (See page LU-12)

16. INSTALL RH ENGINE MOUNTING BRACKET AND INSULATOR ASSEMBLY

Install the mounting bracket with the 4 bolts.

Torque: 59 N·m (590 kgf·cm, 44 ft·lbf)

17. INSTALL LH ENGINE MOUNTING BRACKET AND INSULATOR ASSEMBLY

Install the mounting bracket with the 4 bolts.

Torque: 59 N·m (590 kgf·cm, 44 ft·lbf)

18. INSTALL FUEL INLET PIPE

Install the fuel inlet pipe with the 2 bolts.

Torque: 29 N·m (290 kgf·cm, 21 ft·lbf)

19. INSTALL NO. 1 OIL PIPE

Install the No. 1 oil pipe with 2 new gaskets and the union bolt.

Torque: 55 N·m (550 kgf·cm, 41 ft·lbf)

20. INSTALL OIL FILTER, OIL COOLER AND BRACKET ASSEMBLY

- (a) Install a new O-ring to the oil filter bracket.

- (b) Install a new gasket to the union bolt.
 (c) Install the oil filter bracket with the union bolt.

Torque: 90 N·m (900 kgf·cm, 65 ft·lbf)

- (d) Connect the water bypass hose to the union.

21. INSTALL OIL PRESSURE SWITCH AND KNOCK SENSORS (See page LU-1, FI-63)

22. INSTALL CYLINDER HEAD (See page EM-53)

23. INSTALL WATER PUMP (See page CO-7)

24. INSTALL TRANSMISSION OIL COOLER AND NO. 2 WATER BYPASS PIPE WITH HOSE

- (a) Install the transmission oil cooler and No. 2 water bypass pipe with hose and 6 bolts.

Torque:

Oil cooler	29 N·m (296 kgf·cm, 21 ft·lbf)
Water bypass pipe	21 N·m (214 kgf·cm, 15 ft·lbf)

- (b) Connect the water bypass hose.

25. INSTALL TIMING PULLEYS AND BELT (See page EM-24)

26. INSTALL ALTERNATOR

Install the alternator and pipe bracket with the bolt and nut.

Torque: 40 N·m (400 kgf·cm, 30 ft·lbf)

27. REMOVE ENGINE STAND FROM ENGINE