

## INSTALLATION

### 1. INSTALL FUEL PRESSURE REGULATOR AND FUEL RETURN JET TUBE ASSEMBLY

- (a) Apply a light coat of gasoline to a new O-ring, and install it to the fuel pressure regulator.
- (b) Push in the fuel pressure regulator to the fuel filter.
- (c) Check that the fuel pressure regulator rotates smoothly. If it does not rotate smoothly, the O-ring may be pinched, so remove the fuel pressure regulator and perform again steps (b) and (c) above.
- (d) Connect the fuel return jet tube to the clamp of the No.2 fuel suction support.

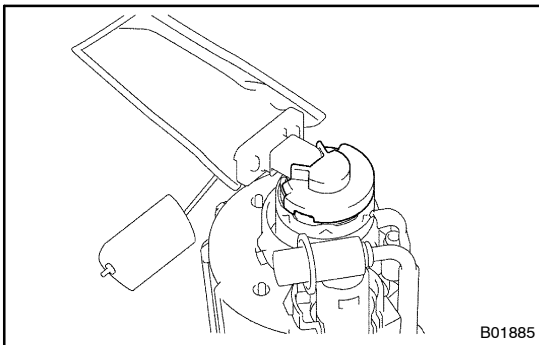

### 2. INSTALL NO.2 FUEL SUCTION SUPPORT

- (a) Install the rubber cushion to the fuel pump.

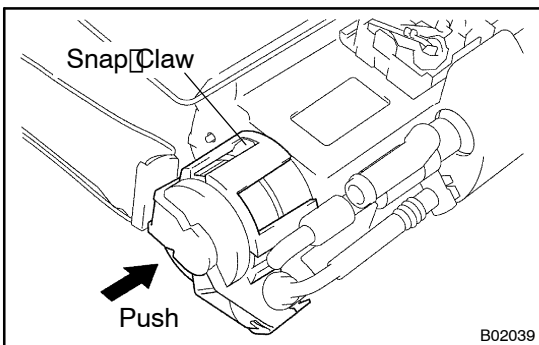

- (b) Push the fuel suction support and attach the 4 snap claws to the claw holes.

### 3. INSTALL FUEL PUMP AND SENDER GAUGE ASSEMBLY TO FUEL TANK (See page FI-13)