

INSPECTION

1. INSPECT INJECTOR INJECTION

CAUTION:

Keep injector clear of sparks during the test.

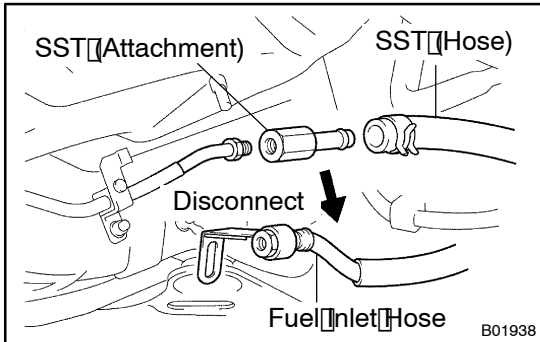

(a) Remove the nut, and disconnect the fuel inlet hose from the fuel main tube.

(b) Temporarily install SST (Attachment) to the fuel main tube.

SST 09268-41047 (09268-52011)

(c) Tighten the flare nut on the fuel main tube (See page FI-1)

(d) Connect SST (hose) to the SST (attachment).

SST 09268-41047

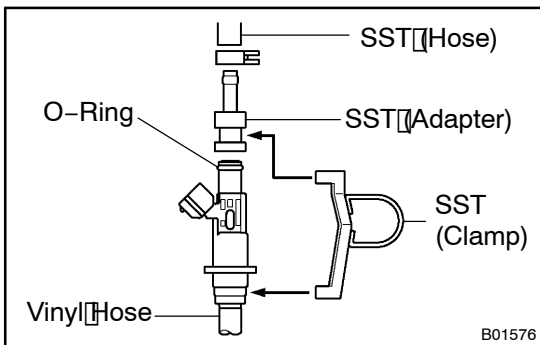

(e) Install the O-ring to the injector.

(f) Connect SST (hose) to the injector with SST (adapter), and hold the injector and adapter with SST (clamp).

SST 09268-41047 (09268-41110, 09268-41300)

(g) Put the injector into the graduated cylinder.

CAUTION:

Install a suitable vinyl hose onto the injector to prevent gasoline from splashing out.

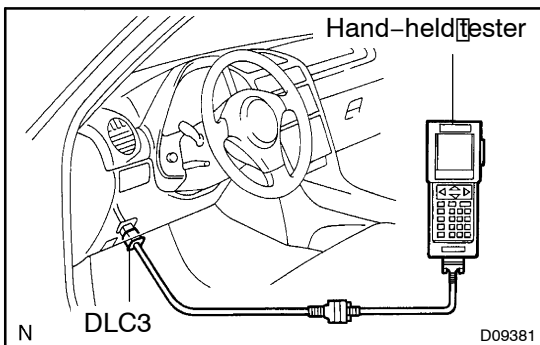

(h) Connect the hand-held tester to the DLC3.

(i) Connect the battery negative (-) terminal cable to the battery.

(j) Turn the ignition switch ON and hand-held tester main switch ON.

NOTICE:

Do not start the engine.

(k) Select the ACTIVE TEST mode on the hand-held tester.

(l) Please refer to the hand-held tester operator's manual for further details.

(m) If you have no hand-held tester, connect the positive (+) and negative (-) leads from the battery to the fuel pump connector (See page FI-6)

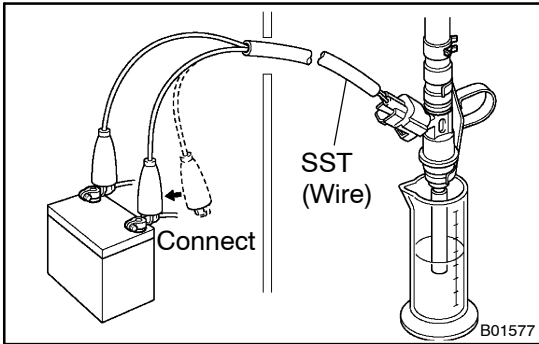

- (n) Connect SST (wire) to the injector and battery for 15 seconds, and measure the injection volume with a graduated cylinder. Test each injector 2 or 3 times.

SST 09842-30070

Injection volume:

60 - 73 cm³ (3.7 - 4.5 cu in.) per 15 seconds

Difference between each injector:

13 cm³ (0.8 cu in.) or less

If the injection volume is not as specified, replace the injector.

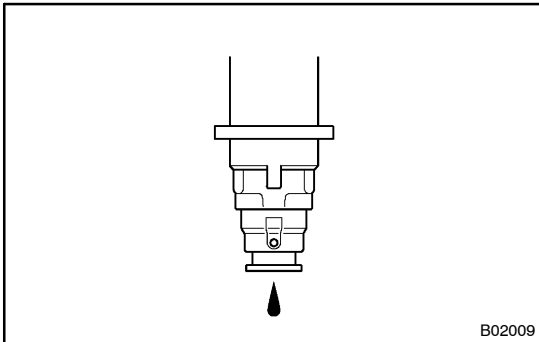

2. INSPECT LEAKAGE

- (a) In the condition above, disconnect the test probes of SST (wire) from the battery and check the fuel leakage from the injector.

SST 09842-30070

Fuel drop: 1 drop or less per 12 minutes

- (b) Turn the ignition switch OFF.
- (c) Disconnect the negative (-) terminal cable from the battery.
- (d) Remove the SST.
SST 09268-41047, 09842-30070
- (e) Reconnect the fuel inlet hose to the fuel main tube (See page FI-1)
- (f) Install the fuel inlet hose with the nut.
Torque: 9 N·m (90 kgf·cm, 80 in.-lbf)
- (g) Disconnect the hand-held tester from the DLC3.