

INSPECTION

1. REMOVE AIR FLOW METER METER

- (a) Disconnect the air flow meter connector.
- (b) Remove the 2 screws, air flow meter and gasket.

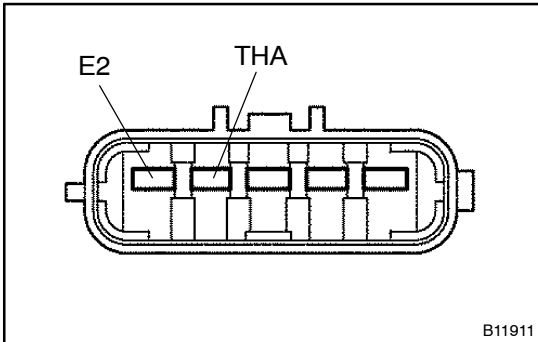

2. INSPECT AIR FLOW METER RESISTANCE

Using an ohmmeter, measure the resistance between terminals THA and E2.

Terminals	Resistance	Temperature
THA-E2	13.6 - 18.4 k Ω	-20°C (-4°F)
THA-E2	2.21 - 2.69 k Ω	20°C (68°F)
THA-E2	0.493 - 0.667 k Ω	60°C (140°F)

If the resistance is not as specified, replace the air flow meter.

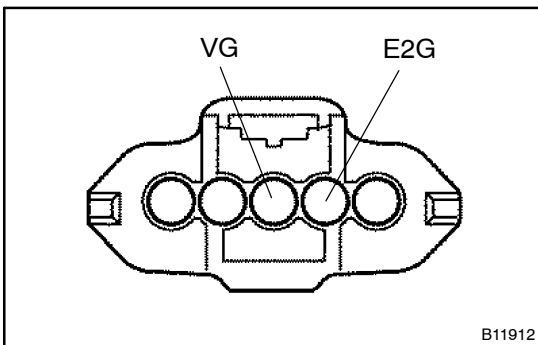

3. INSPECT AIR FLOW METER OPERATION

- (a) Connect the air flow meter connector.
- (b) Connect the negative (-) terminal cable to the battery.
- (c) Turn the ignition switch ON.
- (d) Using a voltmeter, connect the positive (+) tester probe to terminal VG, and negative (-) tester probe to terminal E2G.
- (e) Blow air into the air flow meter, and check that the voltage fluctuates.

If operation is not as specified, replace the air flow meter.

- (f) Turn the ignition switch OFF.
- (g) Disconnect the negative (-) terminal cable from the battery.
- (h) Disconnect the air flow meter connector.

4. REINSTALL AIR FLOW METER

- (a) Install the gasket to the air flow meter.
- (b) Install the air flow meter with the 2 screws.

Torque: 0.69 N·m (7 kgf·cm 0.5 in·lbf)

- (c) Connect the air flow meter connector.