

THROTTLE BODY ON-VEHICLE INSPECTION

1. REMOVE ENGINE COVER

Remove the 4 nuts and engine cover.

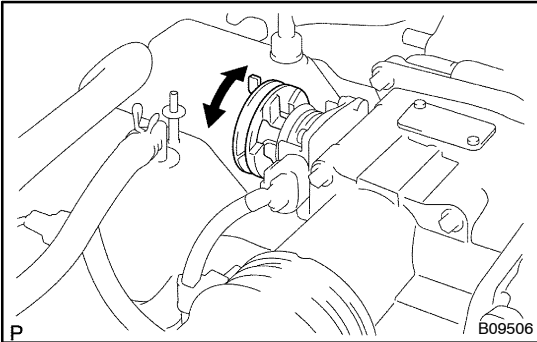

2. INSPECT SYSTEM OPERATION

(a) Check that the throttle linkage moves smoothly.

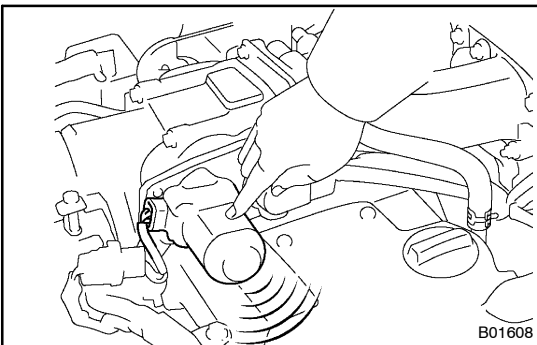

- (b) Inspect the throttle control motor for operating sound.
- (1) Turn the ignition switch ON.
 - (2) When turning the accelerator pedal position sensor lever, check the running sound of the motor. Also, check that there is no friction sound.

If operation is not as specified, check the throttle control motor, wiring and engine ECU.

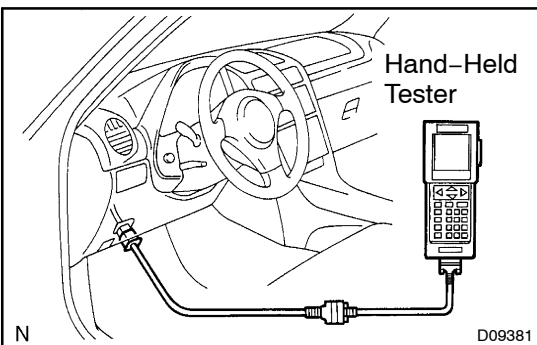

- (c) Inspect the throttle position sensor and accelerator pedal position sensor function.
- (1) Connect the hand-held tester to the DLC3.
 - (2) When turning the accelerator pedal position sensor lever to the full-open position, check that the throttle valve opening percentage (THROTTLE POS) of the CURRENT DATA shows the standard value.

Throttle valve opening percentage: 60 % or more

If operation is not as specified, check that the throttle position sensor, accelerator pedal position sensor, wiring and engine ECU.

- (d) Start the engine, and check that the malfunction indicator Lamp (MIL) does not light up.
- (e) Inspect the air assist system.
- (1) Allow the engine to warm up to normal operating temperature.

- (2) Turn the A/C switch ON and OFF, and check the idle speed.

Idle speed (Transmission in neutral):

700 ± 50 rpm (A/C OFF)

750 ± 50 rpm (A/C ON)

NOTICE:

Perform inspection under condition without electrical load.

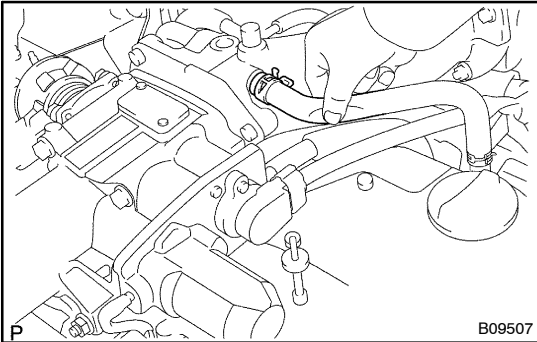

- (3) With engine idling, pinch the air assist hose and check that engine speed drops, and then returns back up to idle speed.

If operation is not as specified, check the throttle body, wiring and engine ECU.

- (f) After checking the above (b) to (e), perform the diving test and check that there is no sense of incongruity.

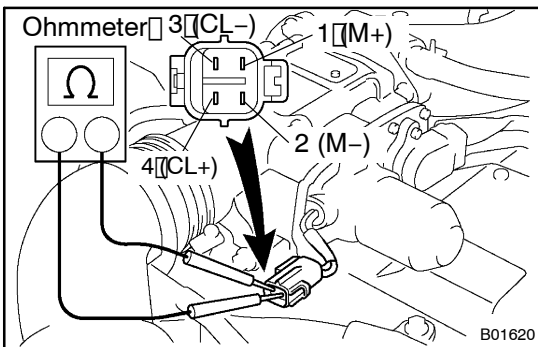

3. INSPECT THROTTLE CONTROL MOTOR

- (a) Disconnect the throttle control motor connector.

- (b) Using an ohmmeter, measure the resistance between terminal 3 (CL-) and 4 (CL+).

Resistance: 4.2 – 5.2 Ω at 20 °C (68 °F)

- (c) Using an ohmmeter, measure the resistance between terminal 1 (M+) and 2 (M-).

Resistance: 0.3 – 100 Ω at 20 °C (68 °F)

If the resistance is not as specified, replace the throttle control motor (See page FI-37).

- (d) Reconnect the throttle control motor connector.

4. INSPECT THROTTLE POSITION SENSOR

- (a) Disconnect the throttle position sensor connector.

- (b) Using an ohmmeter, measure the resistance between terminals VC and E2.

Resistance: 1.2 – 3.2 kΩ at 20 °C (68 °F)

If the resistance is not as specified, replace the throttle position sensor (See page FI-37).

- (c) Reconnect the throttle position sensor connector.

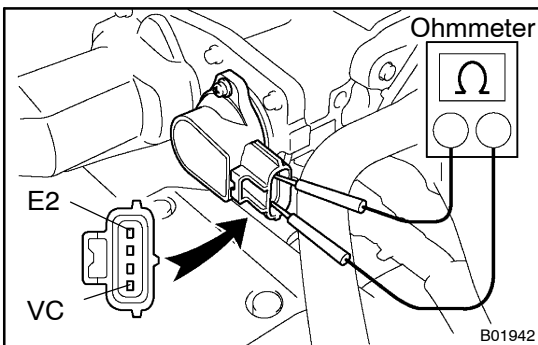

5. INSPECT ACCELERATOR PEDAL POSITION SENSOR

- (a) Disconnect the accelerator pedal position sensor connector.

- (b) Using an ohmmeter, measure the resistance between terminals VC and E2.

Resistance: 1.2 – 3.2 kΩ at 20 °C (68 °F)

If the resistance is not as specified, replace the accelerator pedal position sensor (See page FI-37).

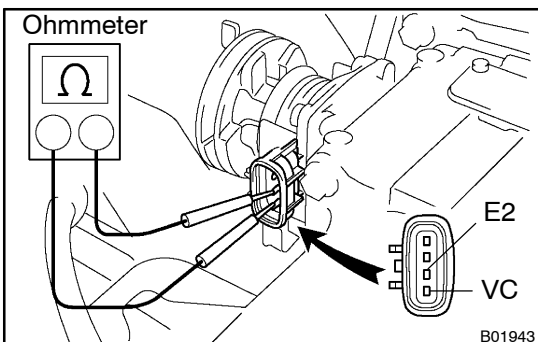

- (c) Reconnect the accelerator pedal position sensor connector.

6. REINSTALL ENGINE COVER

Reinstall the engine cover with the 4 nuts.