

## DISASSEMBLY

### 1. REMOVE DIFFERENTIAL CARRIER COVER

- Remove the 3 bolts from the carrier cover.
- Using a brass bar and hammer, separate the cover from the carrier.
- Remove the breather plug from the differential carrier cover.
- Remove the bolt and oil deflector from the differential carrier cover.

### 2. REMOVE DIFFERENTIAL CARRIER STRAIGHT PIN

Using pliers, remove the straight pin from the differential carrier.

### 3. SET DIFFERENTIAL CARRIER TO OVERHAUL STAND, ETC.

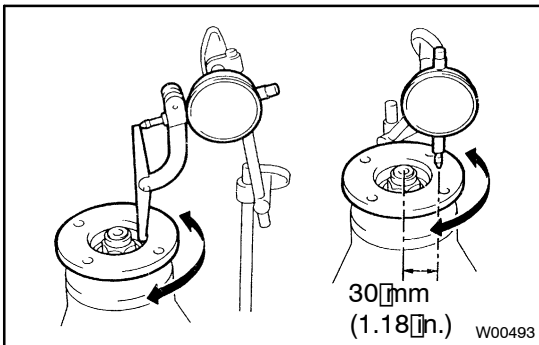

### 4. CHECK COMPANION FLANGE RUNOUT

Using a dial indicator, measure the vertical and lateral runout of the companion flange.

**Maximum runout: 0.09 mm (0.0035 in.)**

If the runout is greater than the maximum, replace the companion flange.

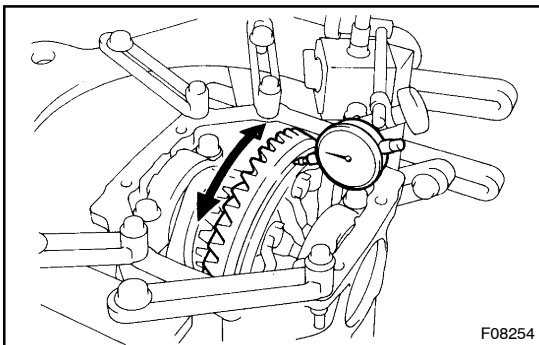

### 5. CHECK RING GEAR RUNOUT

Using a dial indicator, while turning the companion flange measure the ring gear runout.

**Maximum runout: 0.07 mm (0.0028 in.)**

If the runout is greater than the maximum, replace the ring gear and drive pinion as a set.

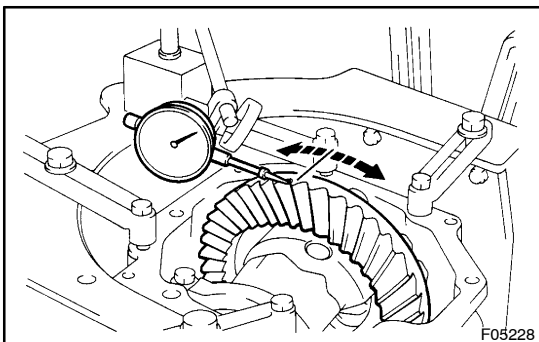

### 6. CHECK RING GEAR BACKLASH

Using a dial indicator, while holding the companion flange measure the ring gear backlash.

**Backlash: 0.13 - 0.18 mm (0.0051 - 0.0071 in.)**

**HINT:**

Measure at 3 or more places on the circumference of the ring gear.

If the backlash is not within the specified value, adjust the backlash (See page SA-56).

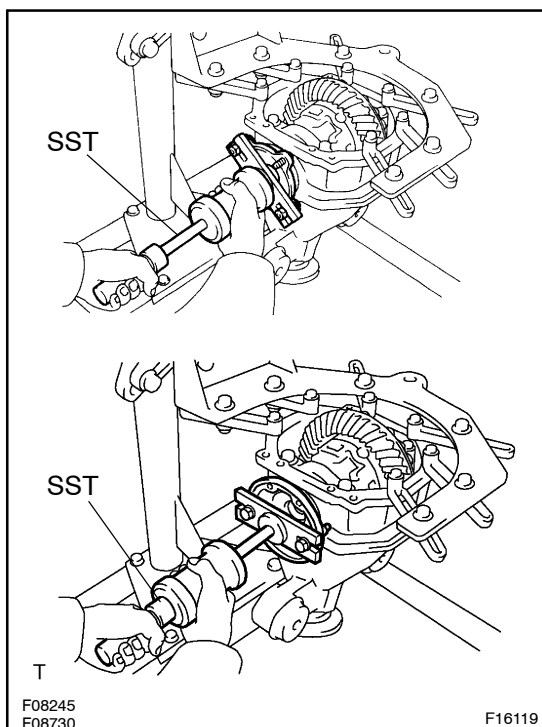

## 7. REMOVE SIDE GEAR SHAFTS

- (a) 1G-FE Engine:  
Using SST and the 2 nuts, remove the 2 side gear shafts from the differential carrier.  
SST 09520-24010
- (b) 2JZ-GE Engine:  
Using SST and the 2 bolts, remove the 2 side gear shafts from the differential carrier.  
SST 09520-24010
- (c) Using a screwdriver, remove the 2 snap rings from the side gear shafts.

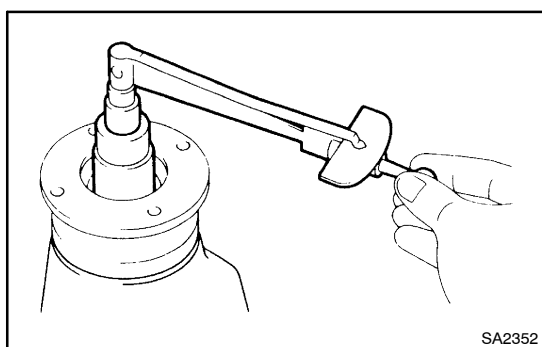

## 8. MEASURE DRIVE PINION PRELOAD

Using a torque wrench, measure the drive pinion preload using the backlash of the drive pinion and ring gear.

**Preload (at starting):**

**0.5 - 0.8 N·m (5 - 8 kgf·cm, 4.3 - 6.9 in.·lbf)**

## 9. CHECK TOTAL PRELOAD

Using a torque wrench, measure the total preload with the teeth of the drive pinion and ring gear in contact.

**Total preload (at starting):**

**Drive pinion preload plus**

**0.4 - 0.6 N·m (4 - 6 kgf·cm, 3.5 - 5.2 in.·lbf)**

If necessary, disassemble and inspect the differential.

## 10. INSPECT TOOTH CONTACT BETWEEN RING GEAR AND DRIVE PINION (See page SA-56)

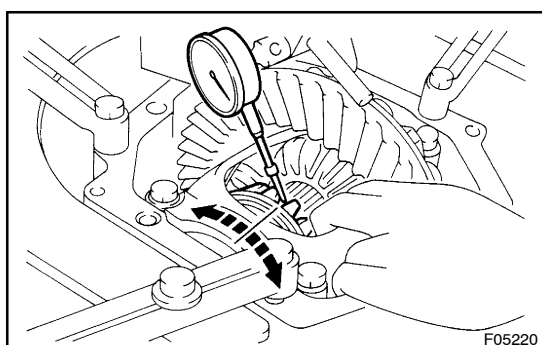

## 11. 2 pinion differential:

### CHECK SIDE GEAR BACKLASH

Using a dial indicator, measure the side gear backlash while holding one pinion gear toward the differential case.

**Backlash: 0.05 - 0.20 mm (0.0020 - 0.0079 in.)**

If the backlash is not within the specified value, install the correct thrust washers (See page SA-56).

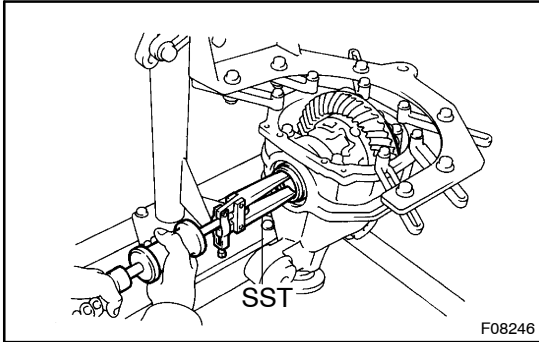
**12. REMOVE SIDE GEAR SHAFT OIL SEALS**

Using SST, remove the 2 side gear shaft oil seals.

SST 09308-00010

**13. REMOVE COMPANION FLANGE**

(a) Using a chisel and hammer, unstake the nut.

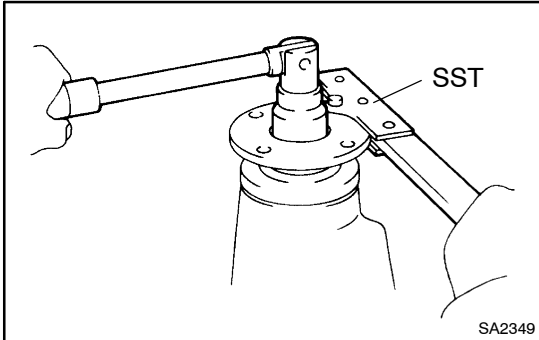

(b) Using SST to hold the flange, remove the nut.

SST 09330-00021

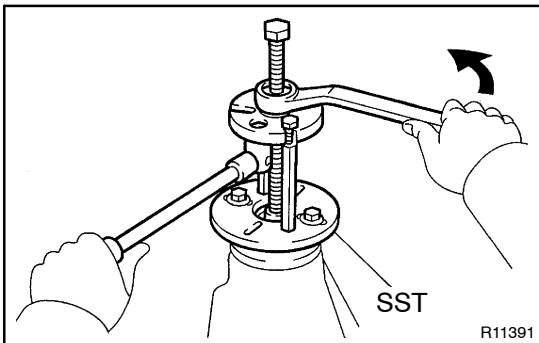

(c) Using SST, remove the companion flange.

SST 09950-30012 (09951-03010, 09953-03010,  
09954-03010, 09955-03030, 09956-03020)

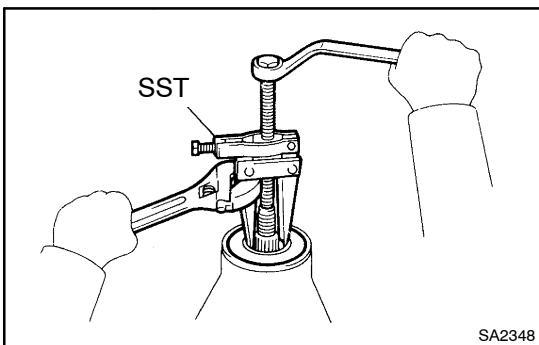
**14. REMOVE FRONT OIL SEAL AND OIL SLINGER**

(a) Using SST, remove the oil seal from the differential carrier.

SST 09308-10010

(b) Remove the oil slinger.

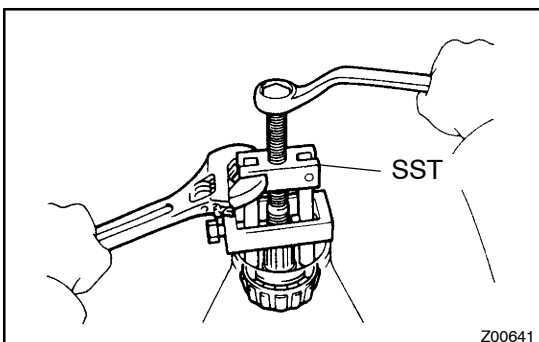
**15. REMOVE FRONT BEARING**

Using SST, remove the front bearing from the drive pinion.

SST 09556-22010

If the front bearing is damaged or worn, replace the front bearing.

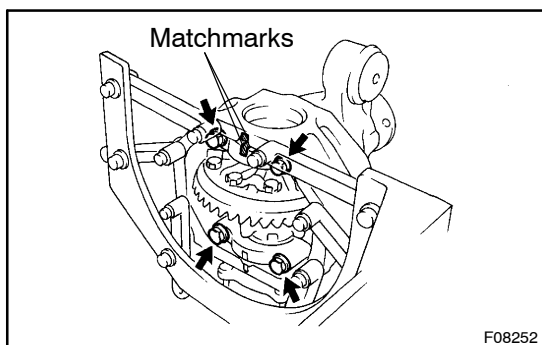
**16. REMOVE DIFFERENTIAL CASE ASSEMBLY**

- (a) Place matchmarks on the bearing cap and differential carrier.
- (b) Remove the 4 bolts and 2 bearing caps.

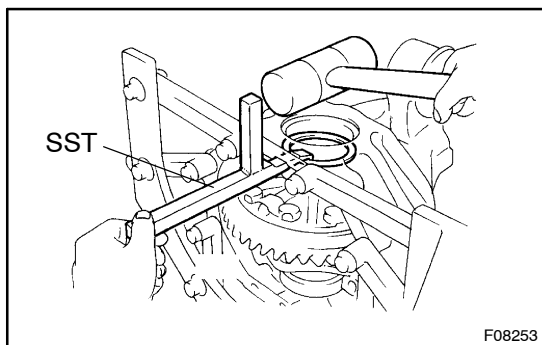

- (c) Using SST and a plastic hammer, remove the 2 plate washers.

SST 09504-22012

**HINT:**

Measure the plate washer and note down the thickness.

- (d) Remove the differential case with the bearing outer races from the differential carrier.

**HINT:**

Tag the bearing outer races to show the location for reassembling.

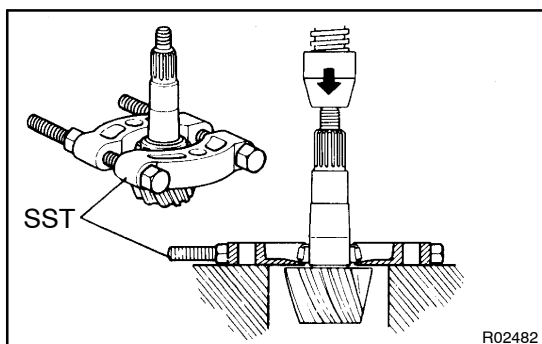
**17. REMOVE DRIVE PINION AND BEARING SPACER FROM DIFFERENTIAL CARRIER****18. REMOVE REAR BEARING**

- (a) Using SST and a press, remove the rear bearing from the drive pinion.

SST 09950-00020

**HINT:**

If the drive pinion or ring gear is damaged, replace them as a set.

- (b) Remove the washer.

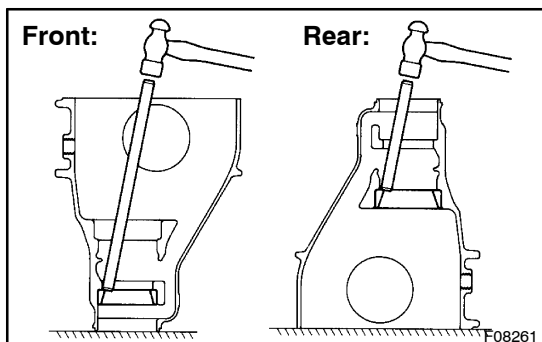
**19. REMOVE FRONT AND REAR BEARING OUTER RACES**

Using a brass bar and hammer, remove the front and rear bearing outer races.

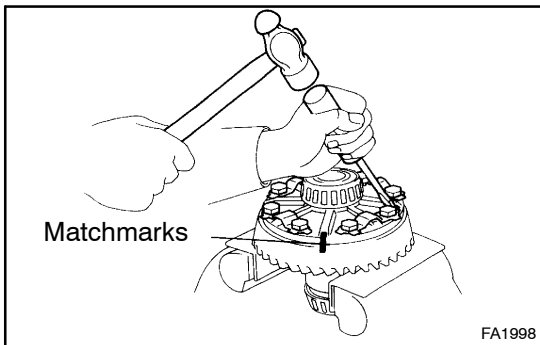
**20. REMOVE RING GEAR**

- (a) Place matchmarks on the ring gear and differential case.
- (b) Using a screwdriver and hammer, unstick the 5 lock plates.
- (c) Remove the 10 bolts and 5 lock plates.
- (d) Using a plastic hammer, tap on the ring gear to separate it from the differential case.

**21. CHECK DIFFERENTIAL CASE RUNOUT**

- (a) Place the bearing outer races on their respective bearings. Check that the right and left outer races are not interchanged.
- (b) Install the assembled plate washers onto the side bearings.
- (c) Install the differential case in the differential carrier.

**HINT:**

If it is difficult to install the differential case into the carrier, replace the plate washer with a thinner one.

However, select a plate washer that allows no clearance between it and the carrier.

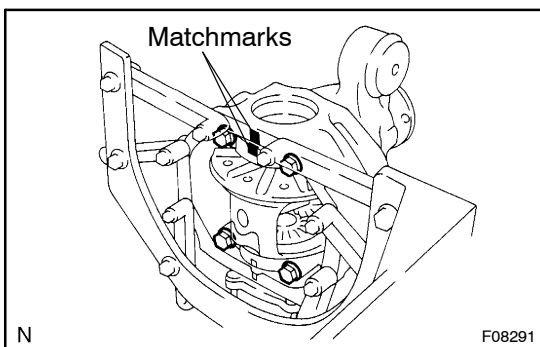

- (d) Align matchmarks on the bearing cap and differential carrier.
- (e) Install and uniformly tighten the 4 bolts a little at a time.

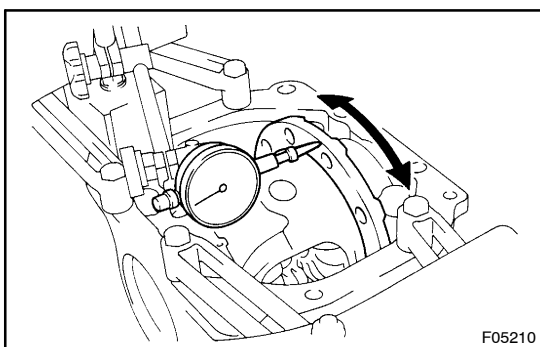

- (f) Using a dial indicator, while turning the companion flange measure the differential case runout.

**Maximum runout: 0.07 mm (0.0028 in.)**

If the runout is greater than the maximum, replace the differential case and side bearings as a set.

- (g) Remove the differential case.

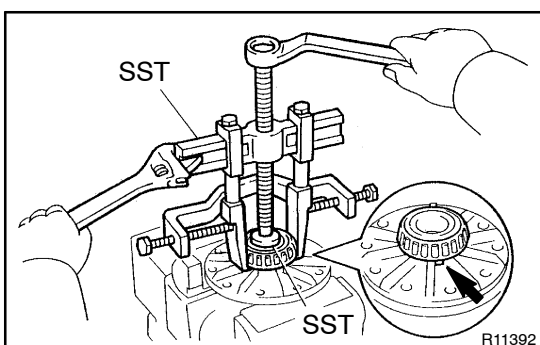
**22. REMOVE SIDE BEARINGS**

- (a) 2 pinion differential:

Using SST, remove the 2 side bearings from the differential case.

SST 09950-40011 (09951-04020, 09952-04010, 09953-04030, 09954-04010, 09955-04061, 09957-04010, 09958-04011), 09950-60010 (09951-00480)

**HINT:**

Fix the claws of SST to the notches in the differential case.

- (b) Torque sensing LSD ring gear side:  
Using SST, remove the side bearing from the differential case.

SST 09950-40011 (09951-04020, 09952-04010, 09953-04030, 09954-04010, 09955-04061, 09957-04010, 09958-04011), 09950-60010 (09951-00480)

HINT:

Fix the claws of SST to the notches in the differential case.

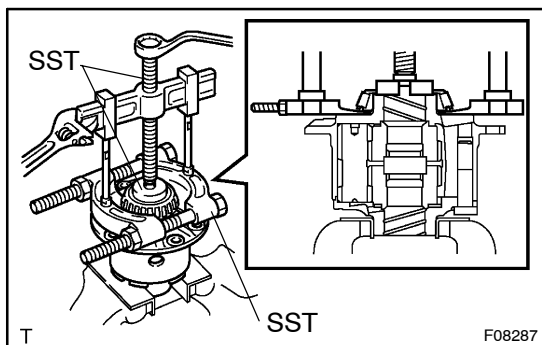

- (c) Torque sensing LSD ring gear back side:  
Using SST, remove the side bearing from the differential case.

SST 09950-00020, 09950-40011 (09951-04020, 09953-04030, 09957-04010), 09950-50012 (09952-05010, 09954-05030, 09955-05040)

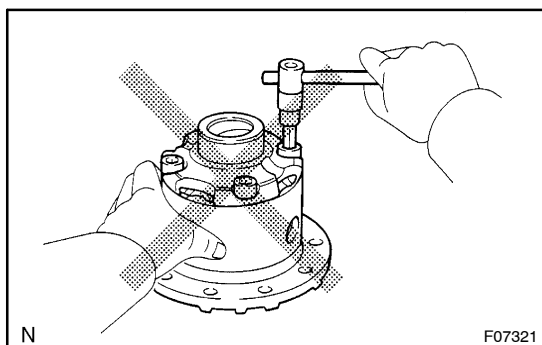

### 23. 2 pinion differential: DISASSEMBLE DIFFERENTIAL CASE ASSEMBLY

#### NOTICE:

If equipped with torque sensing LSD, do not disassemble the differential case.

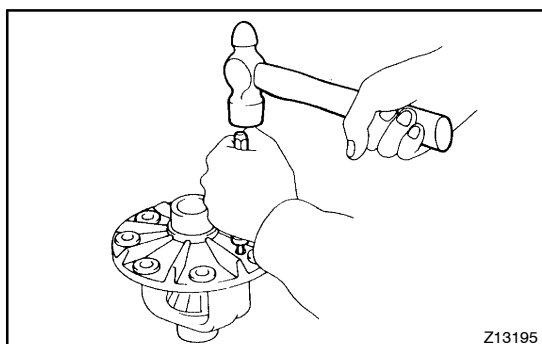

- (a) Using a pin punch (5 mm) and hammer, remove the straight pin.  
(b) Remove the pinion shaft, 2 pinion gears, pinion gear thrust washers, side gears and side gear thrust washers from the differential case.