

DISPOSAL

1. FULLY EXTEND SHOCK ABSORBER ROD

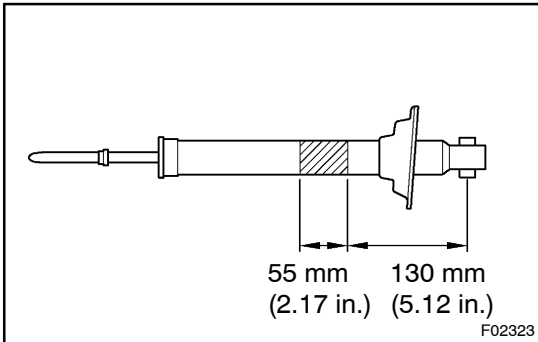

2. DRILL HOLE TO DISCHARGE GAS FROM CYLINDER

Using a drill, make a hole in the cylinder as shown to discharge the gas inside.

CAUTION:

- When drilling, chips may fly out, work carefully.
- The gas is colorless, odorless and non-poisonous.