

## DISASSEMBLY

### 1. CHECK DRIVE SHAFT

- (a) Check that operation of the joint is smooth within the sliding region in the axial direction.

#### HINT:

If a large angle is used for the cross-groove type joint, the joint will be felt like it is catching, but this does not indicate an abnormality.

- (b) Check that the boots are not cracked, damaged or leaking.
- (c) Check that there are no scratches on the speed sensor rotor.

### 2. REMOVE END COVER

- (a) Using a screwdriver, remove the end cover.

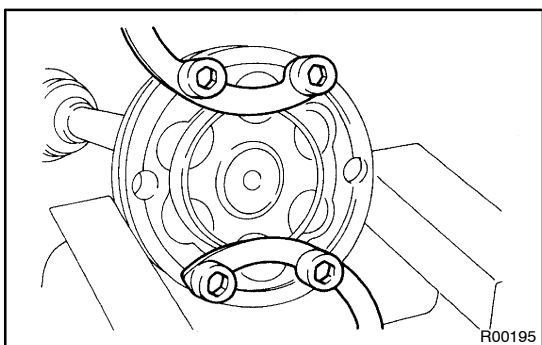

- (b) Use bolts, nuts and washers to keep the inboard joint together.

#### NOTICE:

**Tighten the bolt by hand to avoid scratching the flange surface.**

### 3. REMOVE BOOT CLAMPS

Using a side cutter or pliers, remove the clamps.

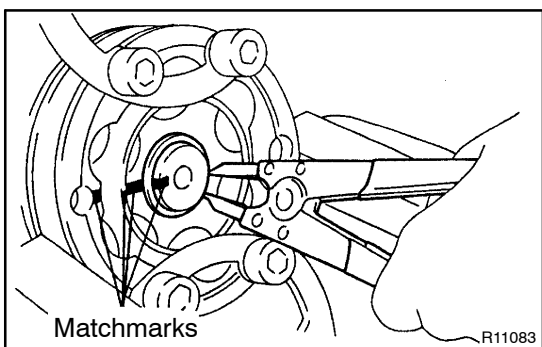

### 4. REMOVE INBOARD JOINT

- (a) Place matchmarks on the inboard joint and drive shaft.
- (b) Using a snap ring expander, remove the snap ring.

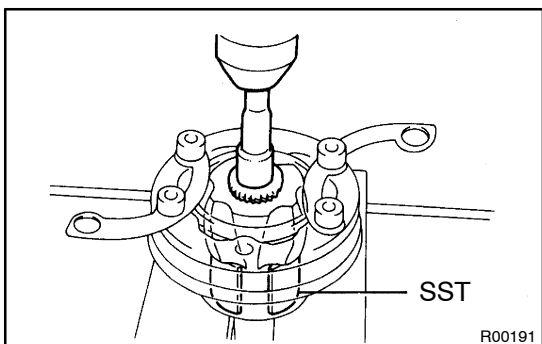

- (c) Using SST, an extension bar and a press, press out the inboard joint from the drive shaft.

SST 09726-12023 (09726-01031)

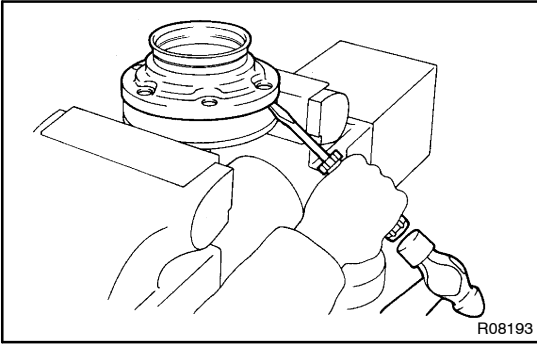

- (d) Mount the inboard joint in a soft jaw vise.
- (e) Using a screwdriver and hammer, tap out the inboard joint cover from the inboard joint.

**NOTICE:**

**Make sure the cage and inner race are not positioned too much to one side of the outer race.**

**5. REMOVE BOOTS**

Remove the inboard and outboard joint boots.