

# AIR CONDITIONING UNIT

## COMPONENTS

AC

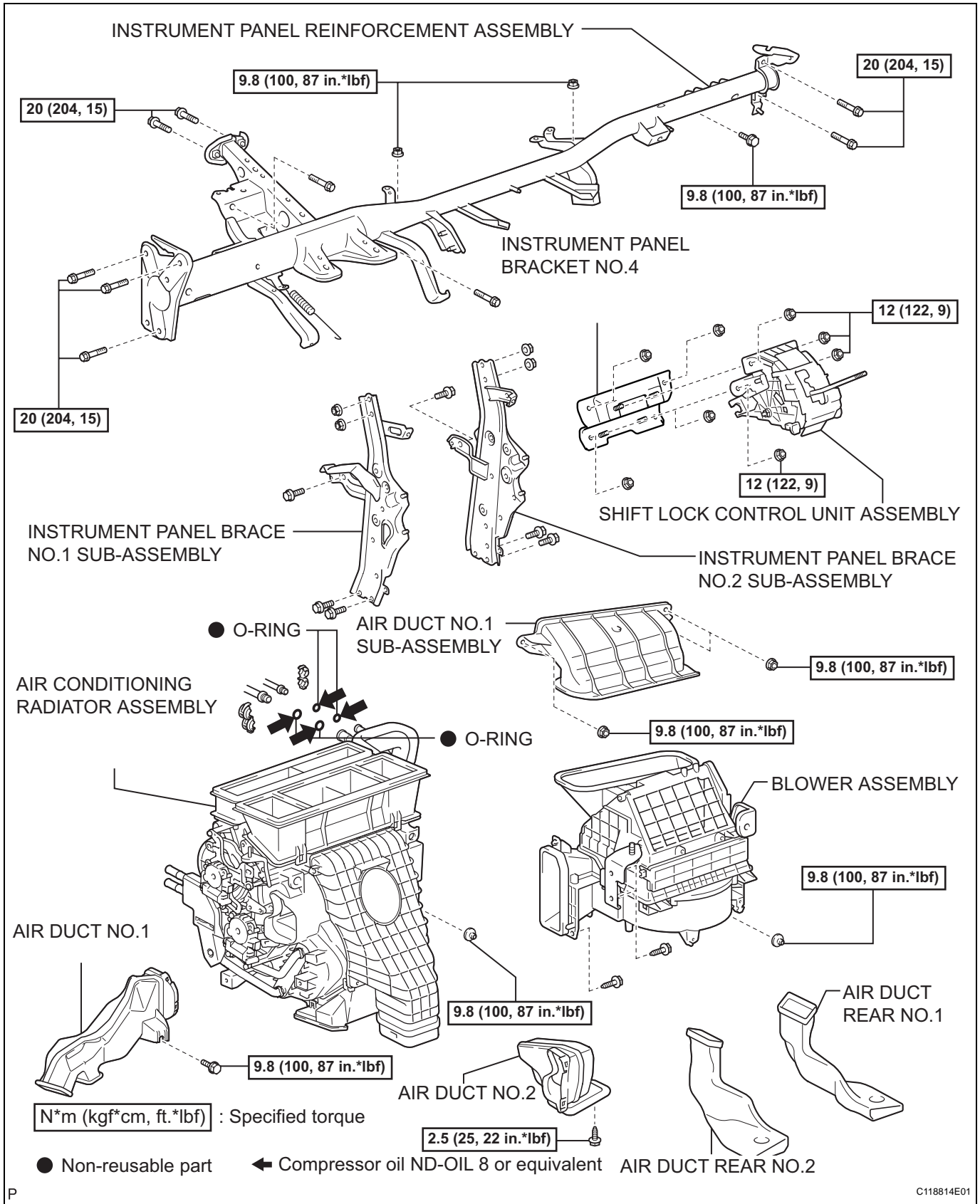

AC

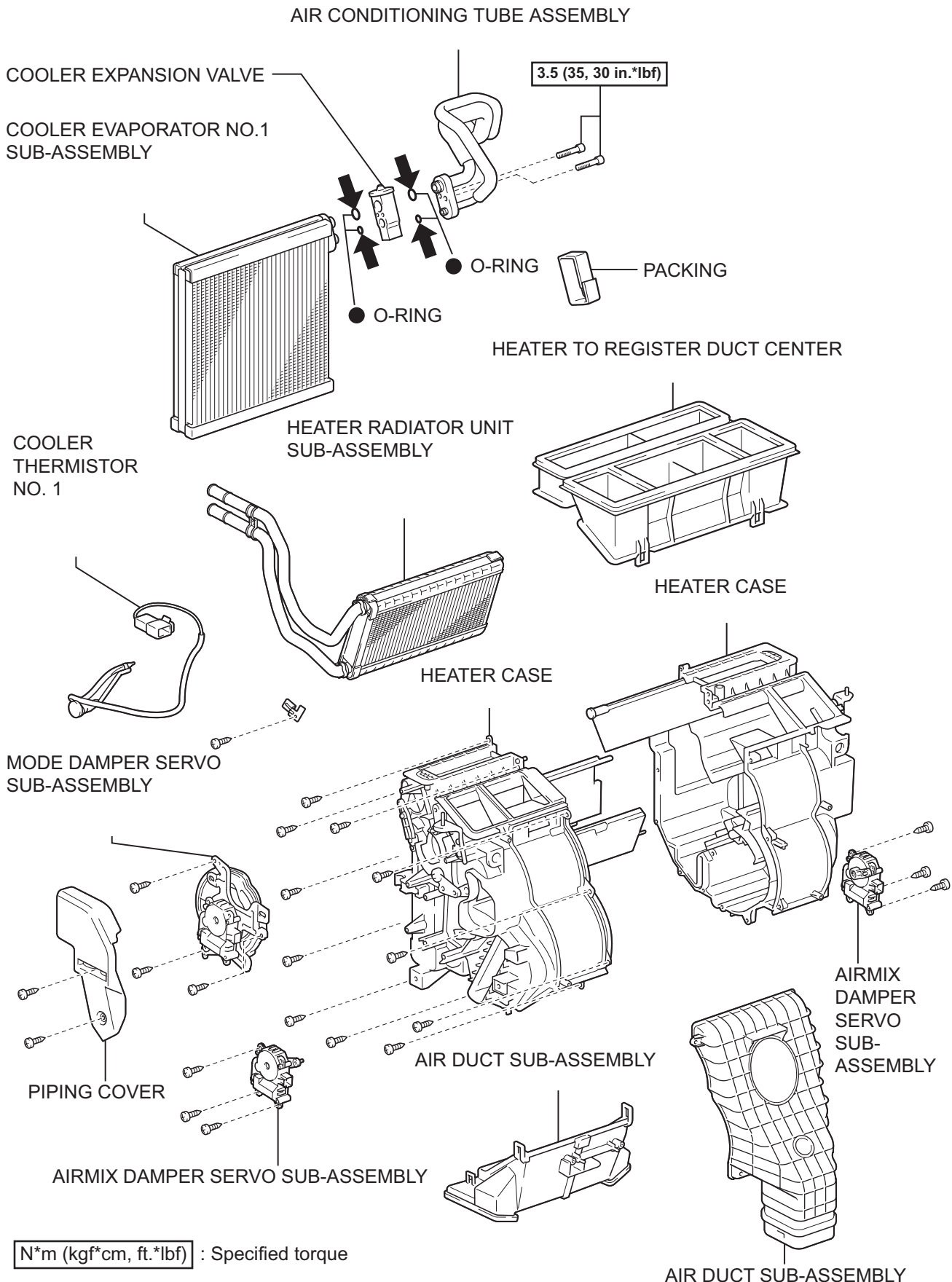

$N*m$  (kgf\*cm, ft.\*lbf) : Specified torque

● Non-reusable part   ← Compressor oil ND-OIL 8 or equivalent