

CONDENSER COMPONENTS

AC

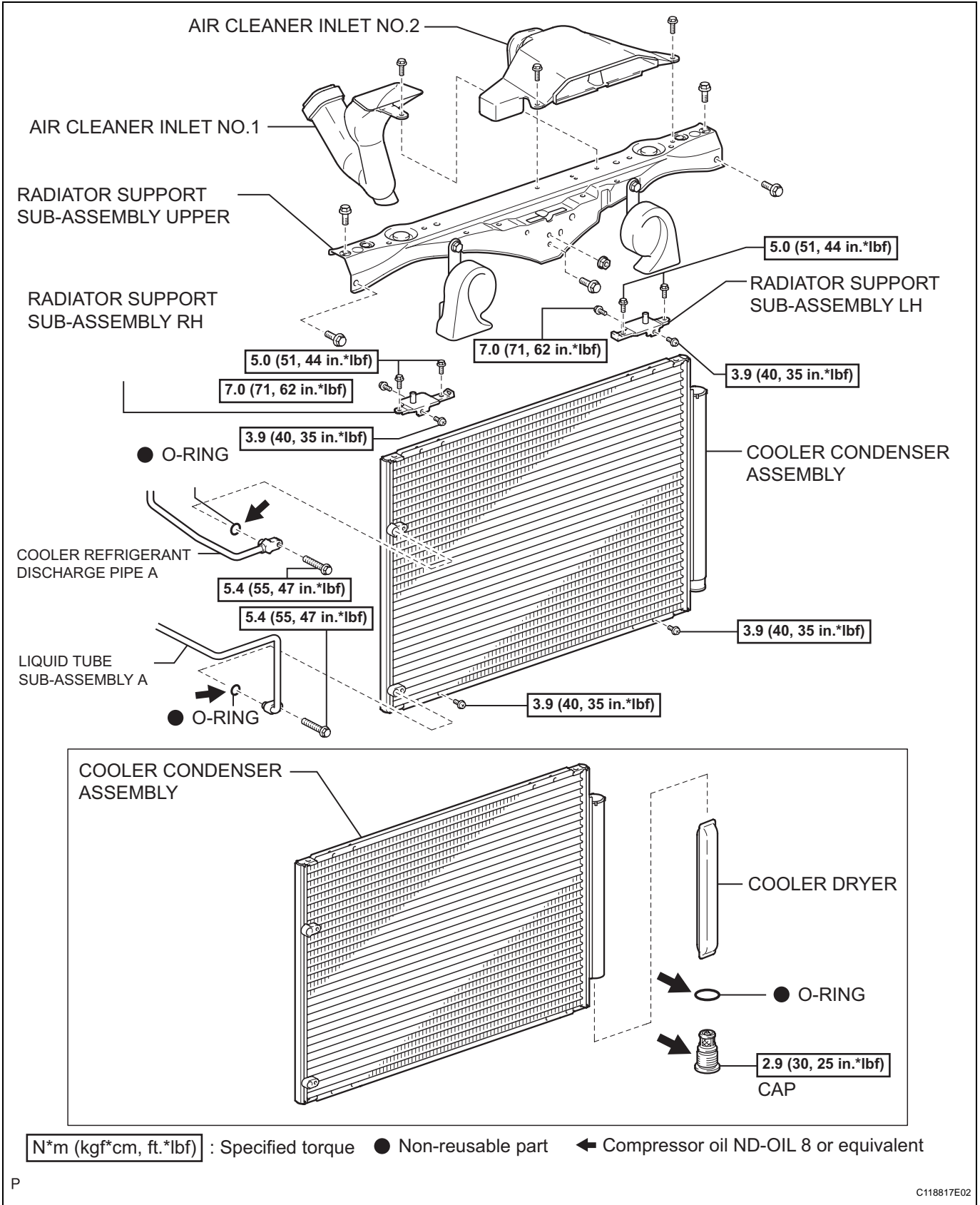

ON-VEHICLE INSPECTION

1. INSPECT COOLER CONDENSER ASSEMBLY

- (a) If the fins of the cooler condenser assembly are dirty, clean them with water and dry them with compressor air.

NOTICE:

Do not damage the fin of the cooler condenser assembly.

- (b) If the fins of the cooler condenser assembly are bent, make them straight using a screwdriver or pliers.

2. INSPECT CONDENSER FOR LEAKAGE OF REFRIGERANT

- (a) Using a halogen leak detector, check the pipe joints for gas leakage.
- (b) If gas leakage is detected in a joint, check the torque of the joint.