

DTC	B1446/46	Air Mix Damper Control Servomotor Circuit (Driver Side)
------------	-----------------	--

DESCRIPTION

The air mix control servo motor (air mix damper servo sub-assembly) is controlled by the A/C amplifier assembly.

The air mix control servo motor moves the air mix damper by rotating (normal, reverse) the motor with electrical power from the A/C amplifier assembly.

This adjusts the mix ratio of the air that passes through the evaporator and heater core and controls the air flow temperature. Air flow temperature changes when moving the air mix damper to the target point. The target point can be detected with the air mix damper position sensor.

AC

DTC No.	DTC Detecting Condition	Trouble Area
B1446/46	Air mix damper position sensor value does not change even if air conditioning amplifier assembly operates air mix control servo motor.	<ul style="list-style-type: none"> Air mix control servo motor Harness or connector between air mix control servo motor and A/C amplifier assembly A/C amplifier assembly

WIRING DIAGRAM

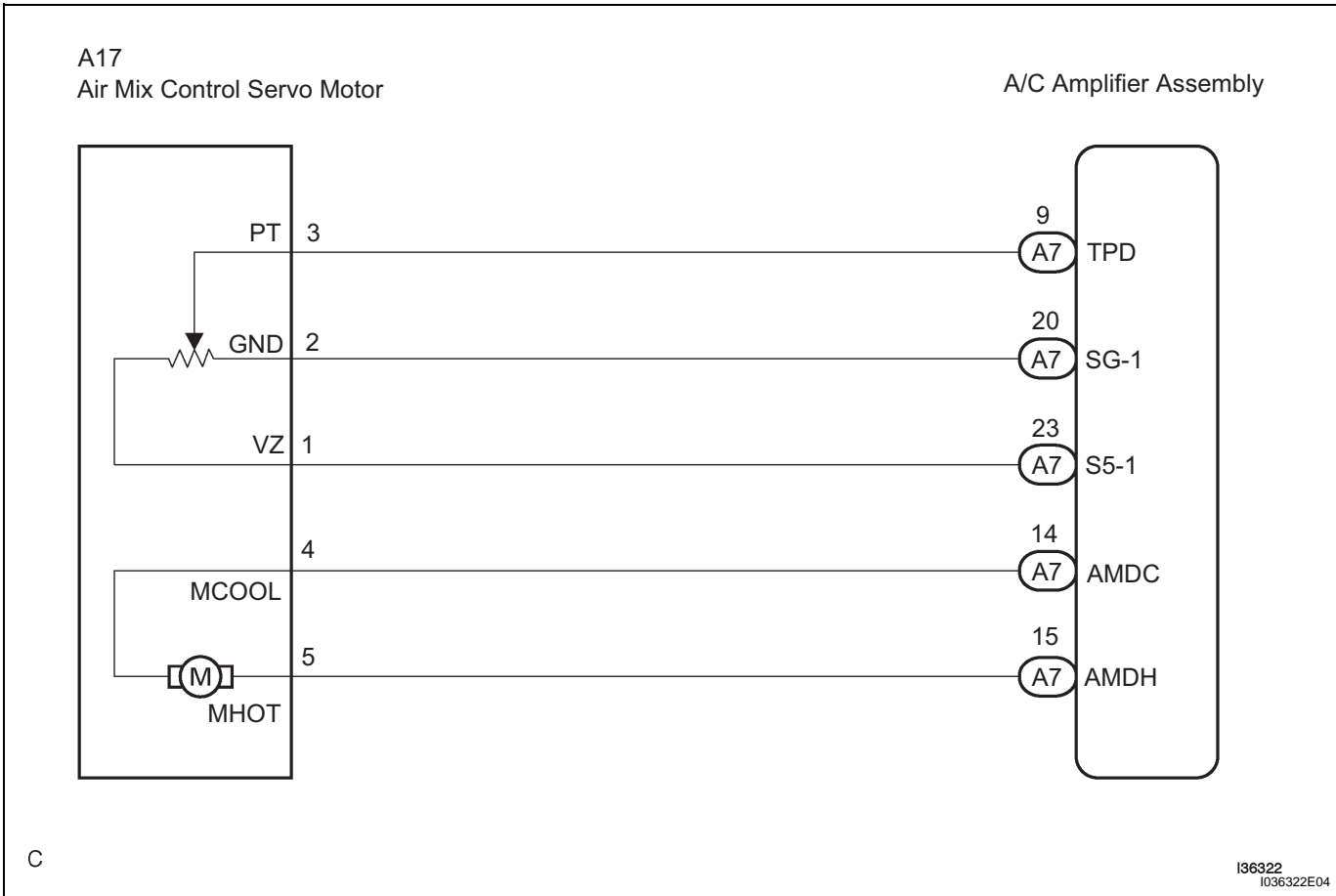

1	READ VALUE OF INTELLIGENT TESTER
----------	---

- (a) Connect the intelligent tester to the DLC3.
- (b) Turn the ignition switch ON and push the intelligent tester main switch on.

- (c) Select the item below in the DATA LIST, and read the display on the intelligent tester.

DATA LIST / AIR CONDITIONER

Item	Measurement Item / Display (Range)	Normal Condition	Diagnostic Note
A/M DAMP POS-D	Air mix damper position (Driver side) / min.: -14% max.: 113.5%	Damper is at "MAX. COOL": -5% Damper is at "MAX. HOT": 105%	-
A/M DAMP TARG-D	Air mix damper target position (Driver side) / min.: -14% max.: 113.5%		

OK:

When the target position is at the "MAX. COOL" (-5%), the actual opening angle is 19.0% or less.
When the target position is at the "MAX. HOT" (105%), the actual opening angle is 81.0% or more.

Result

Result	Proceed to
NG	A
OK (Checking from the PROBLEM SYMPTOM TABLE)	B
OK (Checking from the DTC)	C

B

PROCEED TO NEXT CIRCUIT INSPECTION SHOWN IN PROBLEM SYMPTOMS TABLE

C

REPLACE AIR CONDITIONING AMPLIFIER ASSEMBLY

A

2

PERFORM ACTIVE TEST BY INTELLIGENT TESTER

- (a) Connect the intelligent tester to the DLC3.
- (b) Turn the ignition switch ON and push the intelligent tester main switch on.
- (c) Select the item below in the ACTIVE TEST and then check that the air flow temperature by hand.

ACTIVE TEST / AIR CONDITIONER

Item	Test Details / Display (Range)	Diagnostic Note
AIR MIX DAMP-D	Air mix damper (Driver side) /min.: -14% max.: 113.5%	-

OK:

When the lever is moved to the "MAX. HOT" side, warm air comes out.
When the lever is moved to the "MAX. COOL" side, cool air comes out.

Result

Result	Proceed to
NG	A
OK (Checking from the PROBLEM SYMPTOM TABLE)	B
OK (Checking from the DTC)	C

B

PROCEED TO NEXT CIRCUIT INSPECTION SHOWN IN PROBLEM SYMPTOMS TABLE

C

REPLACE AIR CONDITIONING AMPLIFIER ASSEMBLY

A

3 PERFORM ACTUATOR CHECK

- (a) Set the actuator check mode (See page AC-11).
- (b) Press the DEF switch and change to the step operation.
- (c) Check the air flow temperature by hand.

AC

Display Code	Air Mix Damper Operation
0	"COOL" side (-5%)
1	"COOL" side (-5%)
2	"COOL" side (-5%)
3	"COOL" side (-5%)
4	"COOL"/"HOT" (50% opened)
5	"COOL"/"HOT" (50% opened)
6	"COOL"/"HOT" (50% opened)
7	"HOT" side (105%)
8	"HOT" side (105%)
9	"HOT" side (105%)

OK:

Air flow temperature changes in accordance with each display code.

Result

Result	Proceed to
NG	A
OK (Checking from the PROBLEM SYMPTOM TABLE)	B
OK (Checking from the DTC)	C

B

PROCEED TO NEXT CIRCUIT INSPECTION SHOWN IN PROBLEM SYMPTOMS TABLE

C

REPLACE AIR CONDITIONING AMPLIFIER ASSEMBLY

A

4 INSPECT AIR MIX CONTROL SERVO MOTOR

Air Mix Control Servo Motor Connector Front View:

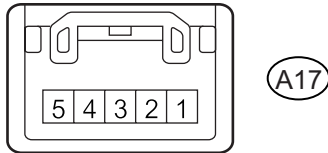

MAX. HOT

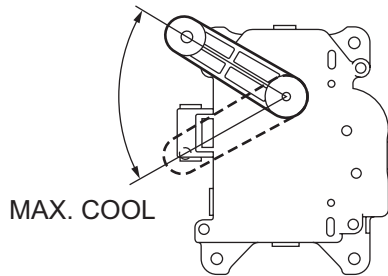

H

E109269E03

- (a) Remove the air mix control servo motor.
- (b) Disconnect the connector from the air mix control servo motor.
- (c) Connect the positive (+) lead from the battery to terminal 5 and negative (-) lead to terminal 4, then check that the lever turns to "MAX. HOT" position smoothly.

OK:

Lever turns to "MAX. HOT" position smoothly.

- (d) Connect the positive (+) lead from the battery to terminal 4 and negative (-) lead to terminal 5, then check that the lever turns to "MAX. COOL" position smoothly.

OK:

Lever turns to "MAX. COOL" position smoothly.

NG

REPLACE AIR MIX CONTROL SERVO MOTOR

OK

AC

5 CHECK HARNESS AND CONNECTOR (AIR MIX CONTROL SERVO MOTOR - A/C AMPLIFIER ASSEMBLY)

Air Mix Control Servo Motor Connector Front View:

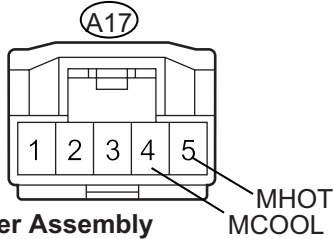

A/C Amplifier Assembly Connector Wire Harness View:

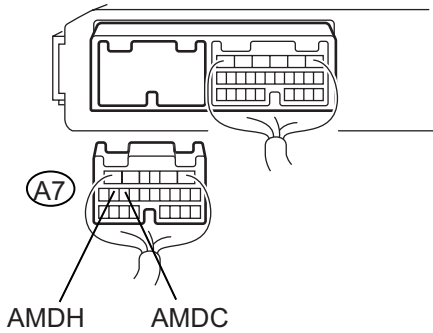

H

E109216E16

- (a) Disconnect the connector from the A/C amplifier assembly.
- (b) Measure the resistance according to the value(s) in the table below.

Standard resistance

Tester connection (Symbols)	Condition	Specified condition
A7-14 (AMDC) - A17-4 (MCOOL)	Always	Below 1 Ω
A7-15 (AMDH) - A17-5 (MHOT)	Always	Below 1 Ω
A7-14 (AMDC) - Body ground	Always	10 kΩ or higher
A7-15 (AMDH) - Body ground	Always	10 kΩ or higher

AC

NG REPAIR OR REPLACE HARNESS OR CONNECTOR

OK

REPLACE AIR CONDITIONING AMPLIFIER ASSEMBLY