

DTC	P0793	Intermediate Shaft Speed Sensor "A"
------------	--------------	--

DESCRIPTION

This sensor detects the rotation speed of the counter gear. By comparing the counter gear speed signal (NC) with the direct clutch speed sensor signal (NT), the ECM detects the shift timing of the gears and appropriately controls the engine torque and hydraulic pressure according to various conditions. Thus smooth gear shifting is performed.

DTC No.	DTC Detection Condition	Trouble Area
P0793	ECM detects conditions (a), (b) and (c) continuously for 5 sec. or more: (1-trip detection logic) (a) Vehicle speed: 50 km/h (31 mph) or more (b) Park/neutral position switch (NSW) is OFF (c) Speed sensor (NC): less than 300 rpm	<ul style="list-style-type: none"> • Open or short in transmission revolution sensor NC (speed sensor NC) circuit • Transmission revolution sensor NC (speed sensor NC) • ECM

Reference (Using an oscilloscope):

Check the waveform between terminals NC+ and NC- of the ECM connector.

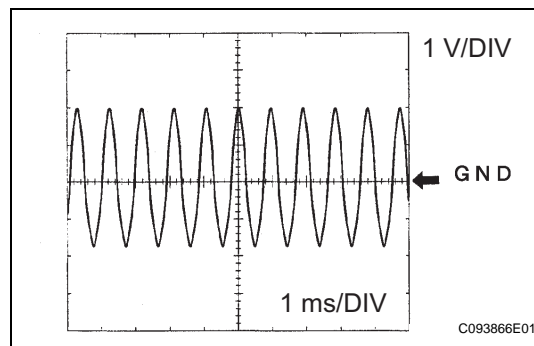

Standard: Refer to the illustration.

Terminal	NC+ - NC-
Tool setting	1 V/DIV, 1ms/DIV
Vehicle condition	Vehicle speed 30 km/h (19 mph): (3rd gear) Engine speed 1,400 rpm

AX

MONITOR DESCRIPTION

The NC terminal of the ECM detects a revolution signal from the speed sensor (NC) (counter gear rpm). The ECM calculates a gearshift comparing the speed sensor (NT) with the speed sensor (NC). While the vehicle is operating in 2nd, 3rd, 4th or 5th gear in the shift position of D, if the counter gear revolution is less than 300 rpm ^{*1} although the output shaft revolution is more than 1,000 rpm ^{*2}, the ECM detects the trouble, illuminates the MIL and stores the DTC.

*1: Pulse is not output or is irregularly output.

*2: The vehicle speed is 50 km/h (31 mph) or more.

MONITOR STRATEGY

Related DTCs	P0793: Speed sensor (NC)/Verify pulse input
Required sensors/Components	Speed sensor (NC), Speed sensor (NT), Park/neutral position switch
Frequency of operation	Continuous
Duration	5 sec.
MIL operation	Immediate
Sequence of operation	None

TYPICAL ENABLING CONDITIONS

The monitor will run whenever this DTC is not present.	P0500 (VSS) P0748, P0778, P0798 (Shift solenoid valve(range))
Engine	Running
NSW switch	OFF
Output shaft rpm	1,000 rpm or more

TYPICAL MALFUNCTION THRESHOLDS

Sensor signal rpm	Less than 300 rpm
-------------------	-------------------

COMPONENT OPERATING RANGE

Counter gear speed sensor (NC)	<p>HINT: 3rd when shift lever position is D position (After warming up the engine);</p> <ul style="list-style-type: none"> Intermediate shaft speed (NC) becomes close to the engine speed.
--------------------------------	--

WIRING DIAGRAM

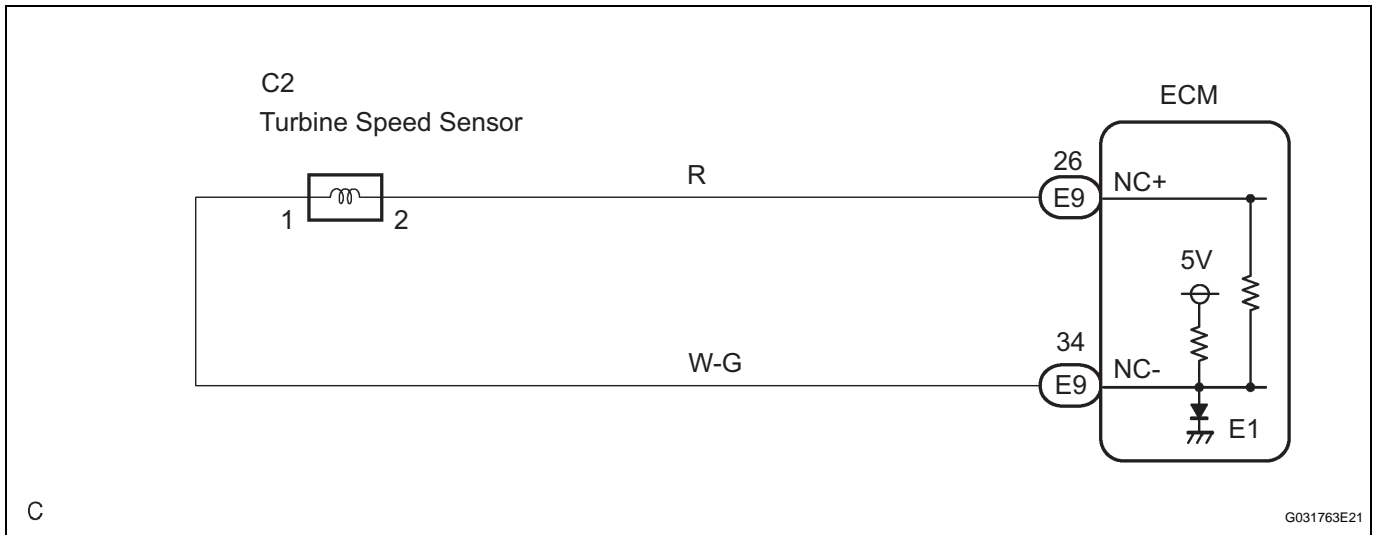

HINT:

According to the DATA LIST displayed by the OBD II scan tool or intelligent tester, you can read the value of the switch, sensor, actuator and so on without parts removal. Reading the DATA LIST as the first step of troubleshooting is one method to shorten labor time.

1. READ DATA LIST

- (a) Warm up the engine.
- (b) Turn the ignition switch off.
- (c) Connect the OBD II scan tool or intelligent tester to the DLC3.
- (d) Turn the ignition switch to the on position.
- (e) Turn on the tester.
- (f) Select the item "DIAGNOSIS / ENHANCED OBD II / DATA LIST".
- (g) According to the display on the tester, read the "DATA LIST".

Item	Measurement Item/ Range (display)	Normal Condition
SPD (NC)	Counter Gear Speed/ display: 50 r/min	<p>[HINT] 3rd when shift lever position is D position (After warming up the engine);</p> <ul style="list-style-type: none"> Intermediate shaft speed (NC) becomes close to the engine speed.

HINT:

- SPD (NC) is always 0 while driving:
Open or short in the sensor or circuit.
- SPD (NC) is always more than 0 and less than 300 rpm while driving the vehicle at 50 km/h (31 mph) or more:
Sensor trouble, improper installation, or intermittent connection trouble of the circuit.

1 INSPECT SPEED SENSOR INSTALLATION

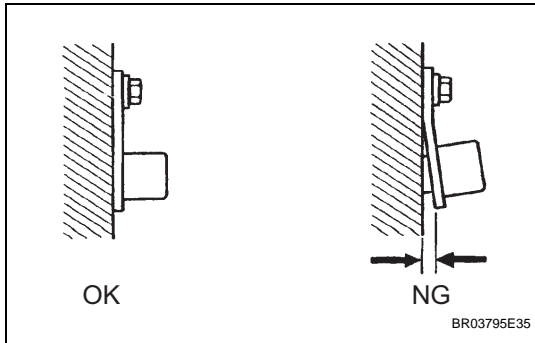

(a) Check the speed sensor installation.

OK:

The installation bolt is tightened properly and there is no clearance between the sensor and transaxle case.

NG → **REPLACE SPEED SENSOR (NC)**

OK

2 INSPECT SPEED SENSOR (NC)

Sensor Side:

(Connector Front View):

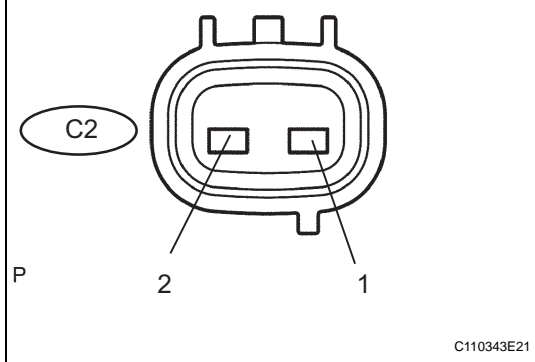

(a) Disconnect the speed sensor connector from the transaxle.

(b) Measure the resistance according to the value(s) in the table below.

Resistance:

TOYOTA made

Tester Connection	Specified Condition 20 °C (68 °F)
1 - 2	500 to 620 Ω

Resistance:

AISIN made

Tester Connection	Specified Condition 20 °C (68 °F)
1 - 2	560 to 680 Ω

NG → **REPLACE SPEED SENSOR (NC)**

OK

3 CHECK HARNESS AND CONNECTOR (SPEED SENSOR - ECM)

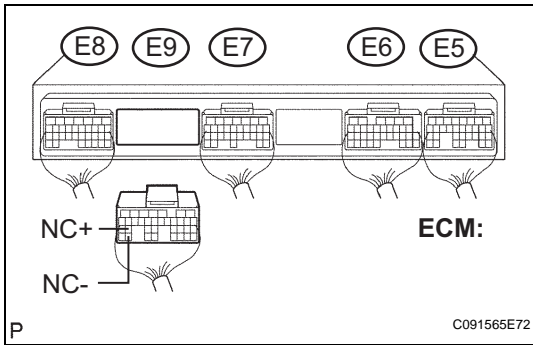

- (a) Connect the speed sensor connector.
- (b) Disconnect the ECM connector.
- (c) Measure the resistance according to the value(s) in the table below.

Resistance:
TOYOTA made

Tester Connection	Specified Condition 20 °C (68 °F)
E9 - 26 (NC+) - E9 - 34 (NC-)	500 to 620 Ω

Resistance:
AISIN made

Tester Connection	Specified Condition 20 °C (68 °F)
E9 - 26 (NC+) - E9 - 34 (NC-)	560 to 680 Ω

- (d) Measure the resistance according to the value(s) in the table below.

Resistance (Check for short)

Tester Connection	Specified Condition
E9 - 26 (NC+) - Body ground	10 kΩ or higher
E9 - 34 (NC-) - Body ground	

NG **REPAIR OR REPLACE HARNESS OR CONNECTOR**

OK

REPLACE ECM