

DTC	P0985	Shift Solenoid "E" Control Circuit Low (Shift Solenoid Valve SR)
DTC	P0986	Shift Solenoid "E" Control Circuit High (Shift Solenoid Valve SR)

DESCRIPTION

Shifting from 1st to 5th is performed in combination with "ON" and "OFF" operation of the shift solenoid valves SL1, SL2, SL3, S4 and SR which are controlled by the ECM. If an open or short circuit occurs in either of the shift solenoid valves, the ECM controls the remaining normal shift solenoid valves to allow the vehicle to be operated smoothly (Fail safe function).

DTC No.	DTC Detection Condition	Trouble Area
P0985	ECM detects short in solenoid valve SR circuit 2 times when solenoid valve SR is operated (1-trip detection logic)	<ul style="list-style-type: none"> Short in shift solenoid valve SR circuit Shift solenoid valve SR ECM
P0986	ECM detects open in solenoid valve SR circuit 2 times when solenoid valve SR is not operated (1-trip detection logic)	<ul style="list-style-type: none"> Open in shift solenoid valve SR circuit Shift solenoid valve SR ECM

MONITOR DESCRIPTION

The ECM commands gear shifts by turning the shift solenoid valves "ON/OFF". When there is an open or short circuit in any shift solenoid valve circuit, the ECM detects the problem and illuminates the MIL and stores the DTC. And the ECM performs the fail-safe function and turns the other normal shift solenoid valves "ON/OFF" (In case of an open or short circuit, the ECM stops sending current to the circuit.) (See page [AX-34](#)).

MONITOR STRATEGY

Related DTCs	P0985: Shift solenoid valve SR/Range check (Low resistance) P0986: Shift solenoid valve SR/Range check (High resistance)
Required sensors/Components	Shift solenoid valve SR
Frequency of operation	Continuous
Duration	0.064 sec.
MIL operation	Immediate
Sequence of operation	None

TYPICAL ENABLING CONDITIONS

P0985: Range check (Low resistance):

The monitor will run whenever this DTC is not present.	None
Shift solenoid valve SR	ON
Battery voltage	8 V or more
Ignition switch	ON
Starter	OFF

P0986: Range check (High resistance):

The monitor will run whenever this DTC is not present.	None
Shift solenoid valve SR	OFF
Battery voltage	8 V or more
Ignition switch	ON
Starter	OFF

TYPICAL MALFUNCTION THRESHOLDS

P0985: Range check (Low resistance):

Shift solenoid valve SR resistance	8 Ω or less
------------------------------------	-------------

P0986: Range check (High resistance):

Shift solenoid valve SR resistance	100 kΩ or more
------------------------------------	----------------

COMPONENT OPERATING RANGE

Shift solenoid valve SR	Resistance: 11 to 15 Ω at 20°C (68°F)
-------------------------	---------------------------------------

WIRING DIAGRAM

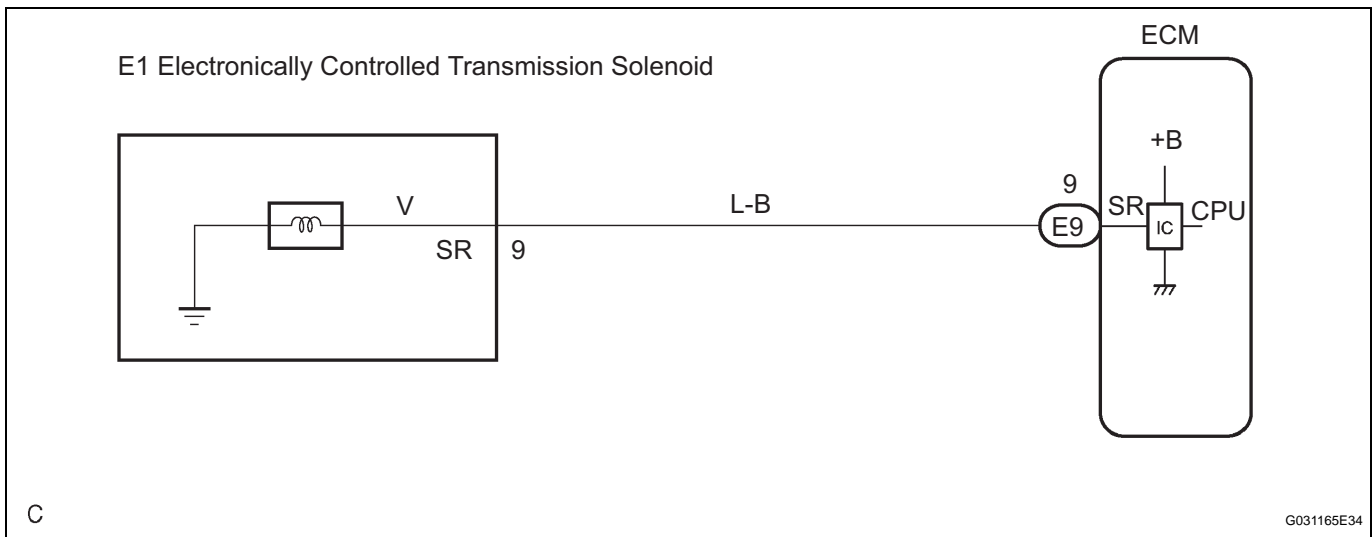

AX

1 INSPECT TRANSMISSION WIRE (SR)

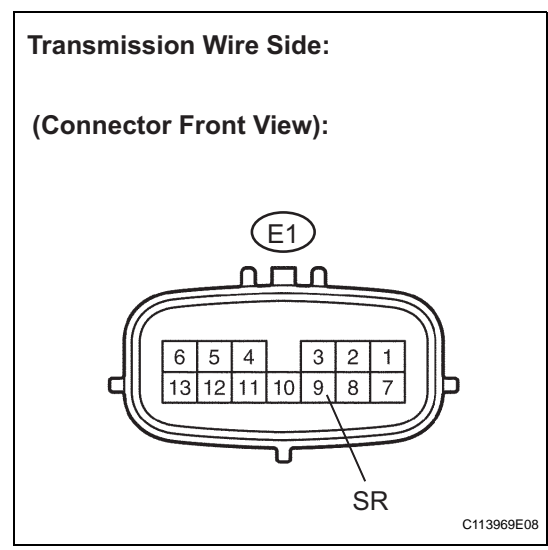

- (a) Disconnect the transmission wire connector from the transaxle.
- (b) Measure the resistance according to the value(s) in the table below.

Resistance

Tester Connection	Specified Condition 20°C (68°F)
9 - Body ground	11 to 15 Ω

NG → **Go to step 3**

OK

2 CHECK HARNESS AND CONNECTOR (TRANSMISSION - ECM)

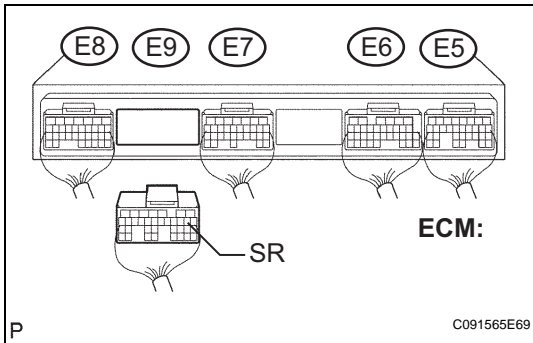

- (a) Connect the transmission connector to the transaxle.
- (b) Disconnect the connector from the ECM.
- (c) Measure the resistance according to the value(s) in the table below.

Resistance

Tester Connection	Specified Condition 20°C (68°F)
E9 - 9 (SR) - Body ground	11 to 15 Ω

NG → **REPAIR OR REPLACE HARNESS OR CONNECTOR**

OK

REPLACE ECM

3 INSPECT SHIFT SOLENOID VALVE (SR)

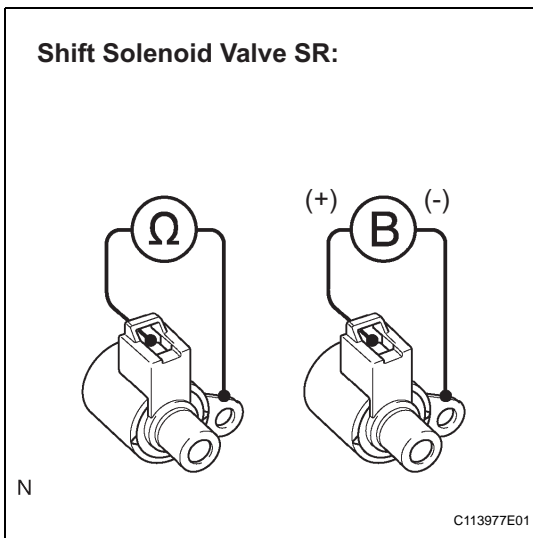

- (a) Remove the shift solenoid valve SR.
- (b) Measure the resistance according to the value(s) in the table below.

Resistance

Tester Connection	Specified Condition 20°C (68°F)
Solenoid Connector (SR) - Solenoid Body (SR)	11 to 15 Ω

- (c) Connect the positive (+) lead to the terminal of the solenoid connector, and the negative (-) lead to the solenoid body.

OK:

The solenoid makes an operating sound.

NG → **REPLACE SHIFT SOLENOID VALVE (SR)**

OK

REPAIR OR REPLACE TRANSMISSION WIRE

AX