

DTC	P2769	Torque Converter Clutch Solenoid Circuit Low (Shift Solenoid Valve DSL)
DTC	P2770	Torque Converter Clutch Solenoid Circuit High (Shift Solenoid Valve DSL)

DESCRIPTION

The shift solenoid valve DSL is turned "ON" and "OFF" by signals from the ECM in order to control the hydraulic pressure operation, the lock-up relay valve, which then controls operation of the lock-up clutch.

DTC No.	DTC Detection Condition	Trouble Area
P2769	ECM detects short in solenoid valve DSL circuit (0.1 sec.) when solenoid valve DSL is operated (2-trip detection logic)	<ul style="list-style-type: none"> • Short in shift solenoid valve DSL circuit • Shift solenoid valve DSL • ECM
P2770	ECM detects open in solenoid valve DSL circuit (0.1 sec.) when solenoid valve DSL is not operated (2-trip detection logic)	<ul style="list-style-type: none"> • Open in shift solenoid valve DSL circuit • Shift solenoid valve DSL • ECM

MONITOR DESCRIPTION

Torque converter lock-up is controlled by the ECM based on engine rpm, engine load, engine temperature, vehicle speed, transmission temperature, and shift range selection. The ECM determines the lock-up status of the torque converter by comparing the engine rpm (NE) to the input turbine rpm (NT). The ECM calculates the actual transmission gear by comparing input turbine rpm (NT) to counter gear rpm (NC). When conditions are appropriate, the ECM requests "lock-up" by applying control voltage to the shift solenoid DSL. When the DSL is opened, it applies pressure to the lock-up relay valve and locks the torque converter clutch. If the ECM detects an open or short in the DSL solenoid circuit, the ECM interprets this as a fault in the DSL solenoid or circuit. The ECM will turn on the MIL and store the DTC.

MONITOR STRATEGY

Related DTCs	P2769: Shift solenoid valve DSL/Range check (Low resistance) P2770: Shift solenoid valve DSL/Range check (High resistance)
Required sensors/Components	Shift solenoid valve DSL
Frequency of operation	Continuous
Duration	0.064 sec. or more
MIL operation	2 driving cycles
Sequence of operation	None

TYPICAL ENABLING CONDITIONS

P2769: Range check (Low resistance):

The monitor will run whenever this DTC is not present.	None
Shift solenoid valve DSL	ON
Solenoid current cut status	Not cut
Battery voltage	8 V or more
Ignition switch	ON
Starter	OFF

P2770: Range check (High resistance):

The monitor will run whenever this DTC is not present.	None
Shift solenoid valve DSL	ON
Battery voltage	8 V or more
Ignition switch	ON

AX

Starter	OFF
---------	-----

TYPICAL MALFUNCTION THRESHOLDS

P2769: Range check (Low resistance):

Shift solenoid valve DSL resistance	8 Ω or less
-------------------------------------	-------------

P2770: Range check (High resistance):

Shift solenoid valve DSL resistance	100 kΩ or more
-------------------------------------	----------------

COMPONENT OPERATING RANGE

Shift solenoid valve DSL	Resistance: 11 to 13 Ω at 20°C (68°F)
--------------------------	---------------------------------------

WIRING DIAGRAM

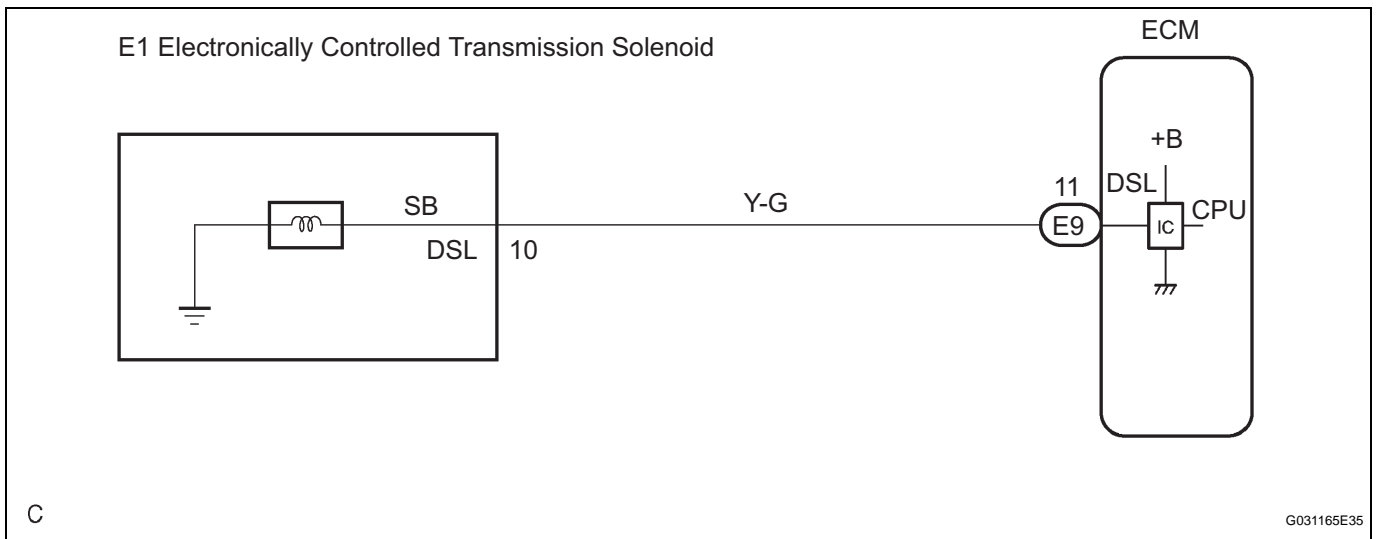

1 INSPECT TRANSMISSION WIRE (DSL)

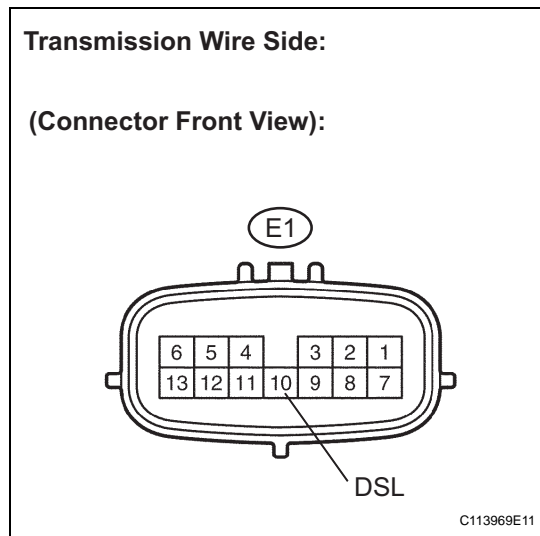

- (a) Disconnect the transmission wire connector from the transaxle.
- (b) Measure the resistance according to the value(s) in the table below.

Resistance

Tester Connection	Specified Condition 20°C (68°F)
10 - Body ground	11 to 13 Ω

NG → **Go to step 3**

OK

2 CHECK HARNESS AND CONNECTOR (TRANSMISSION WIRE - ECM)

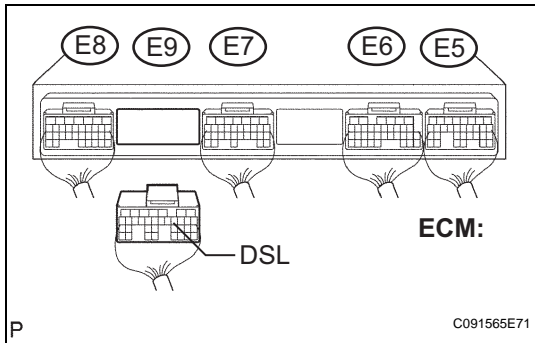

- (a) Connect the transmission wire connector.
- (b) Disconnect the ECM connector.
- (c) Measure the resistance according to the value(s) in the table below.

Resistance

Tester Connection	Specified Condition 20°C (68°F)
E9 - 11 (DSL) - Body ground	11 to 13 Ω

NG **REPAIR OR REPLACE HARNESS OR CONNECTOR**

OK

REPLACE ECM

3 INSPECT SHIFT SOLENOID VALVE (DSL)

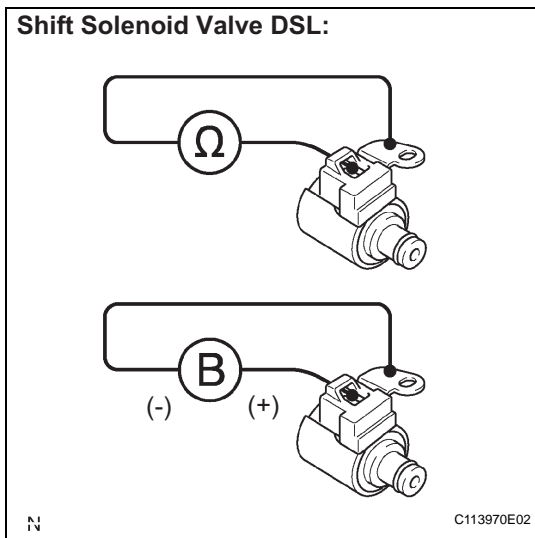

- (a) Remove the shift solenoid valve DSL.
- (b) Measure the resistance according to the value(s) in the table below.

Resistance

Tester Connection	Specified Condition 20°C (68°F)
Solenoid Connector (DSL) - Solenoid Body (DSL)	11 to 13 Ω

- (c) Connect the positive (+) lead to the terminal of the solenoid connector, and the negative (-) lead to the solenoid body.

OK:

The solenoid valve makes an operating sound.

NG **REPLACE SHIFT SOLENOID VALVE (DSL)**

OK

REPAIR OR REPLACE TRANSMISSION WIRE

AX