

# VALVE BODY ASSEMBLY

## COMPONENTS

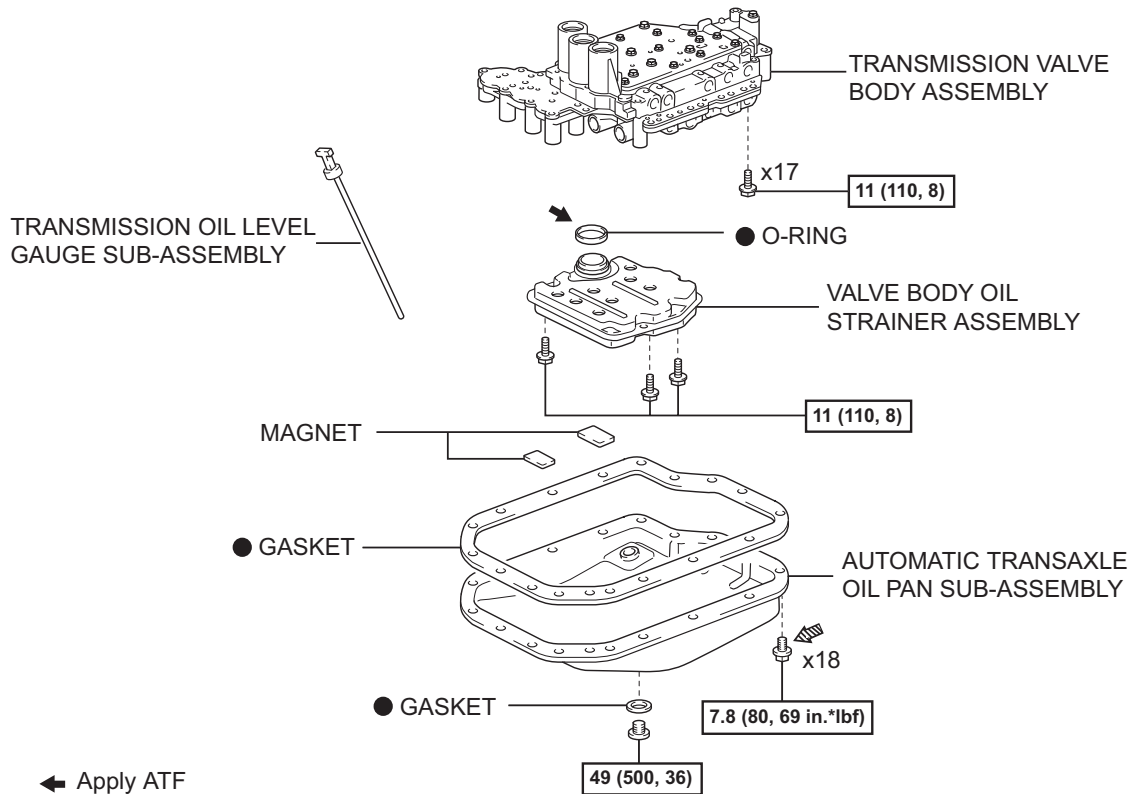
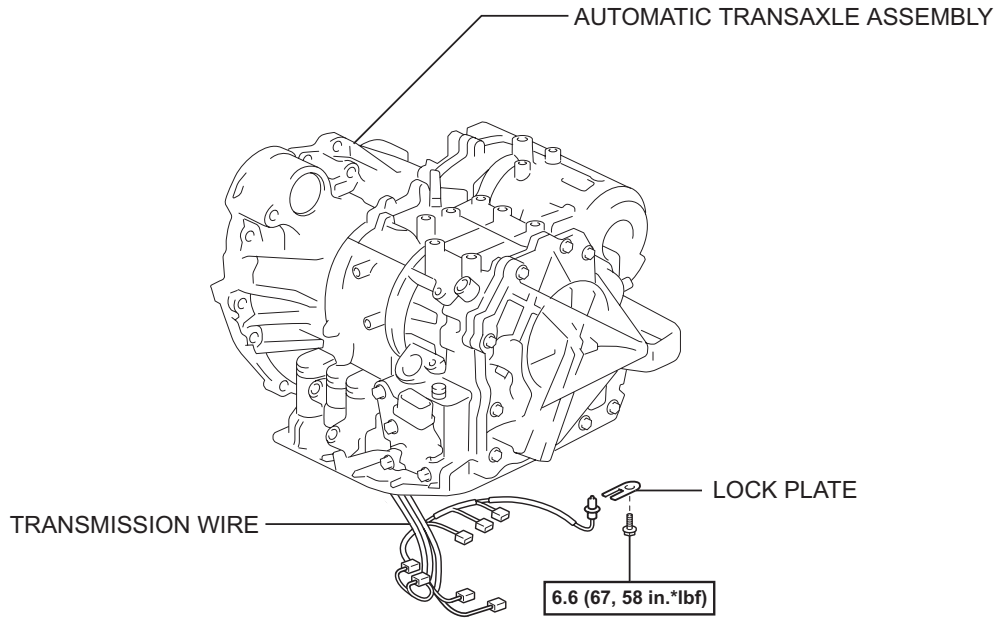

← Apply ATF

▢ Precoated part

● Non-reusable part

**[N\*m (kgf\*cm, ft.\*lbf)]**: Specified torque

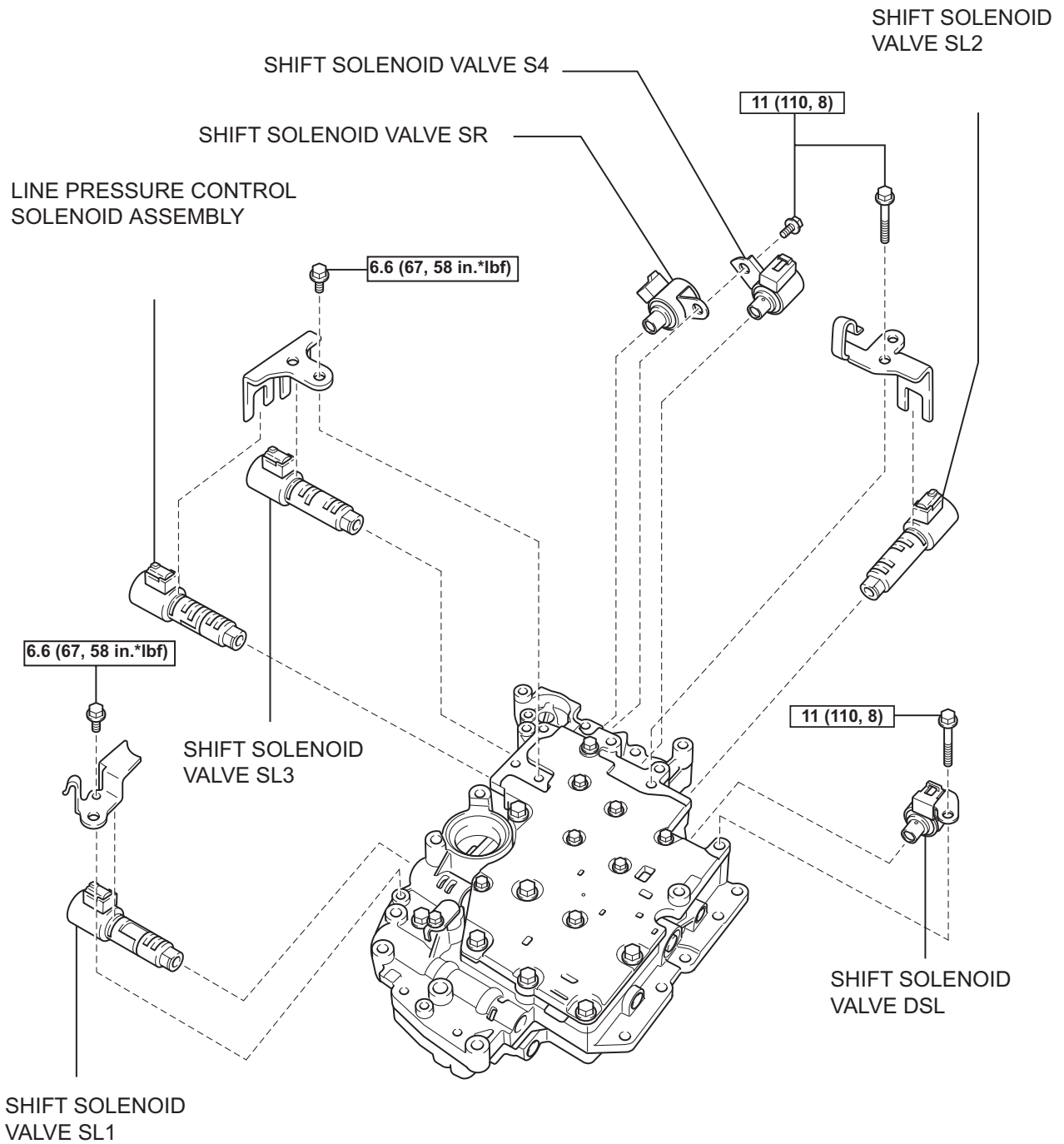

$N*m$  (kgf\*cm, ft.\*lbf) : Specified torque

AX