

# AUTOMATIC TRANSAXLE UNIT

## COMPONENTS

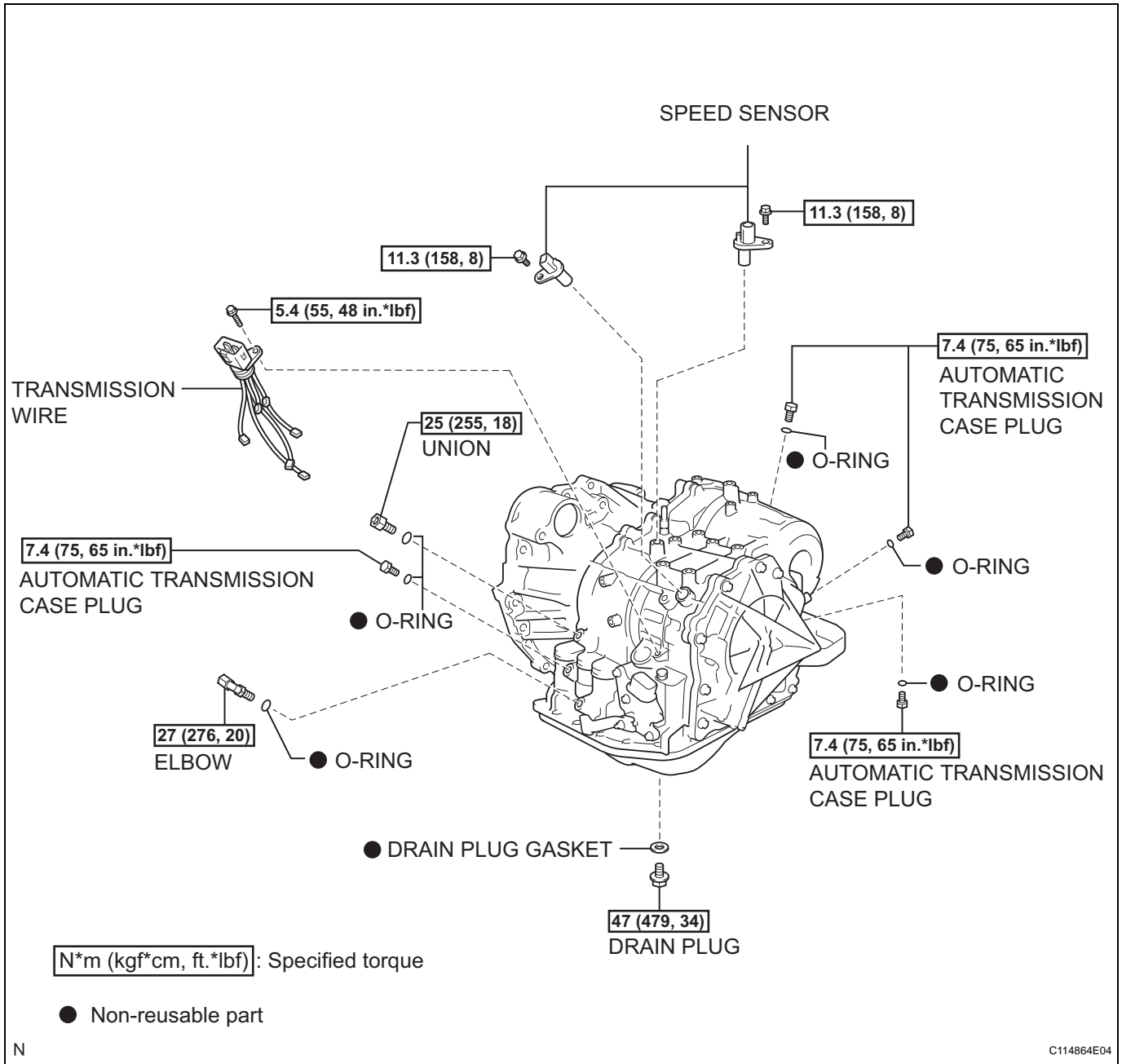

AX

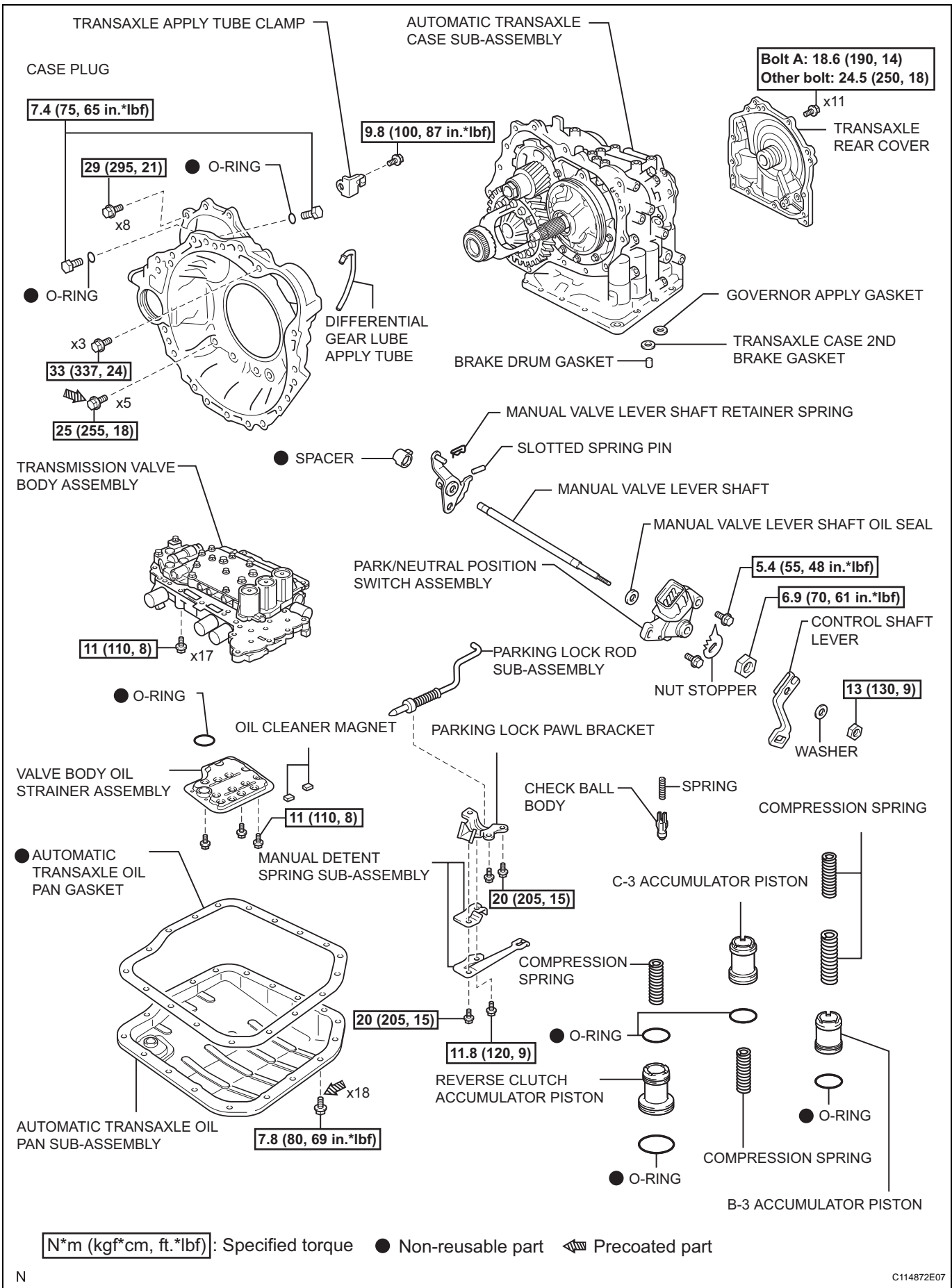

**N\*m (kgf\*cm, ft.\*lbf)** : Specified torque ● Non-reusable part ◀ Precoated part

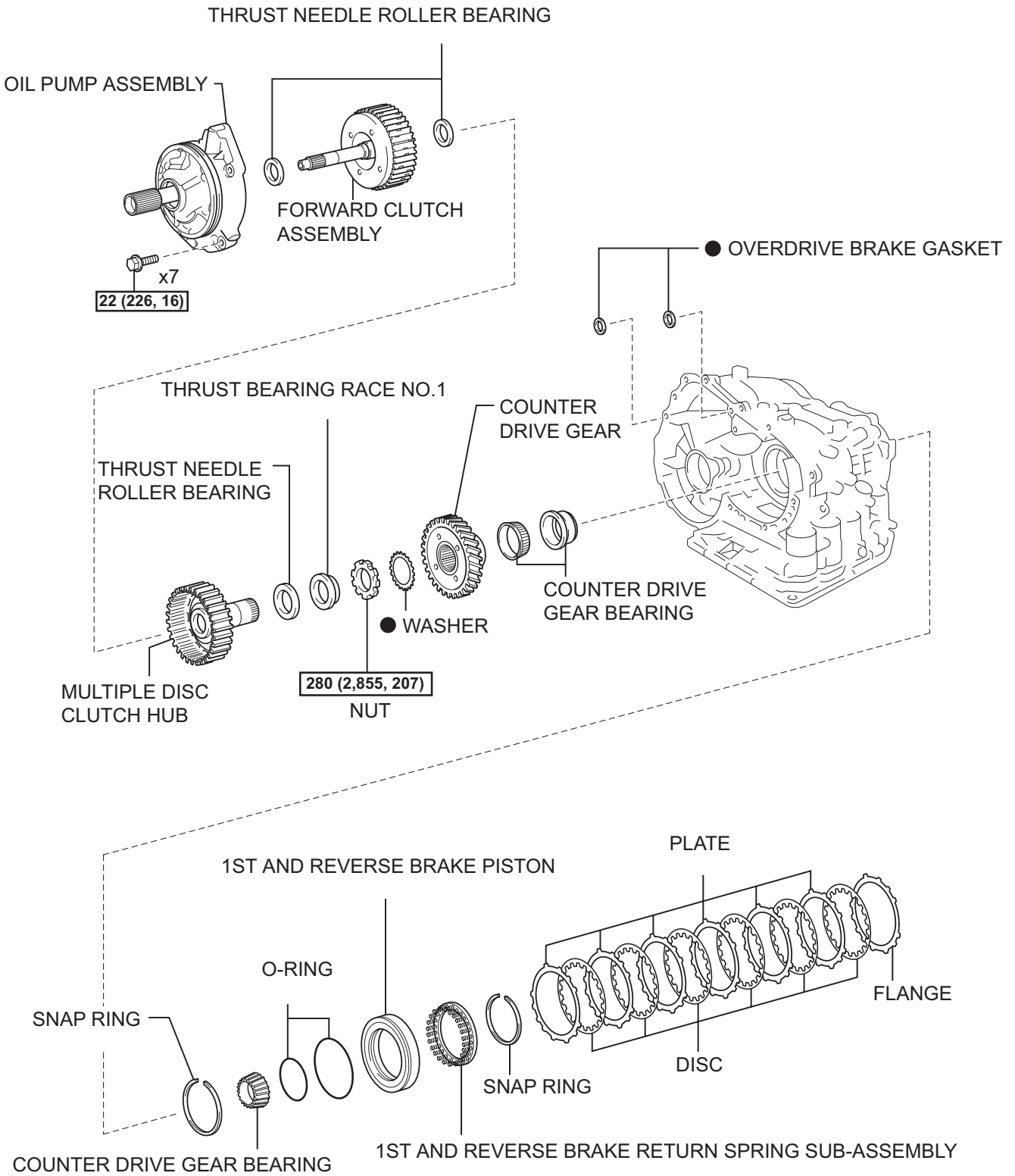

**N\*m (kgf\*cm, ft.\*lbf)**: Specified torque    ● Non-reusable part

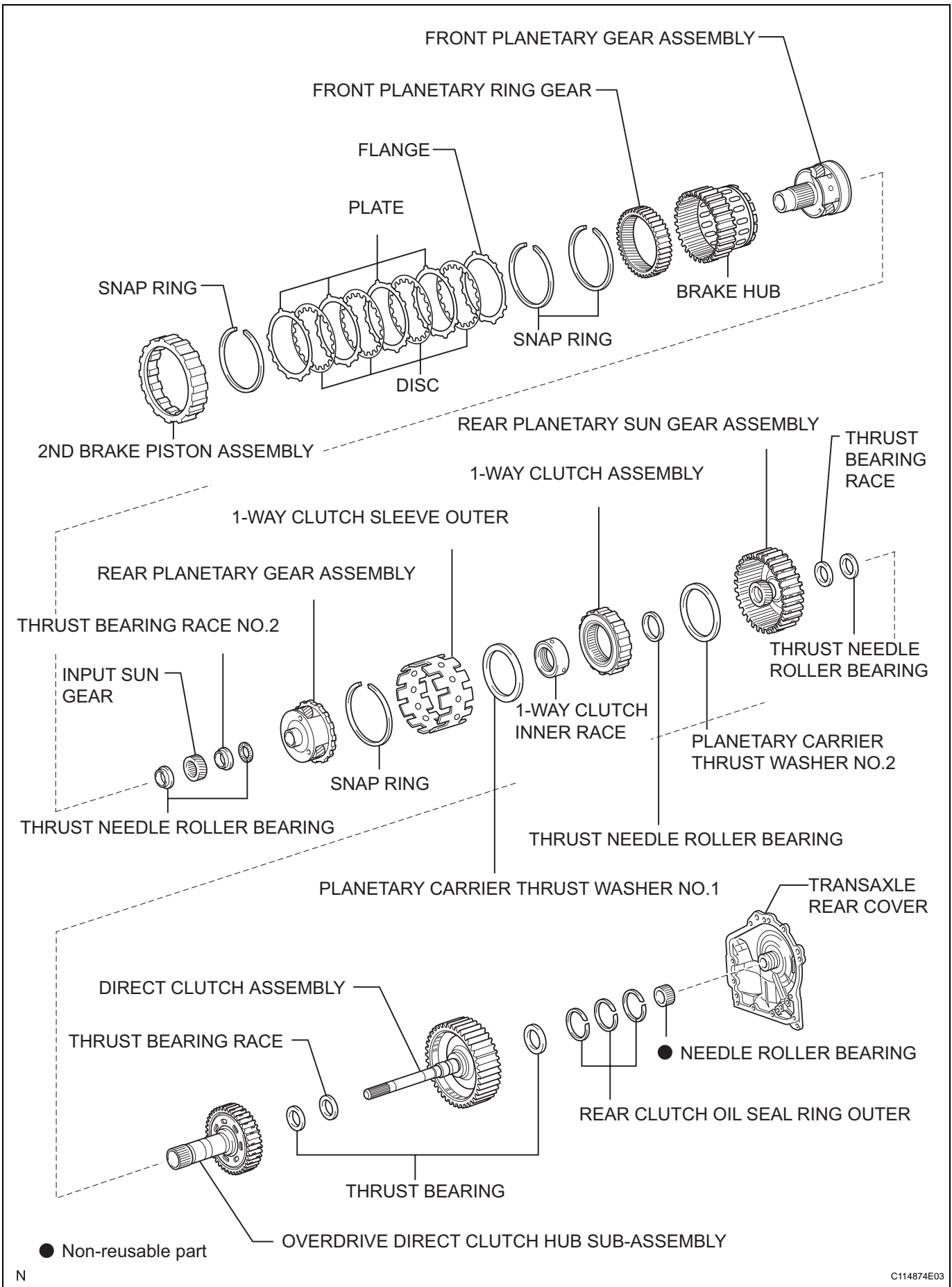

AX

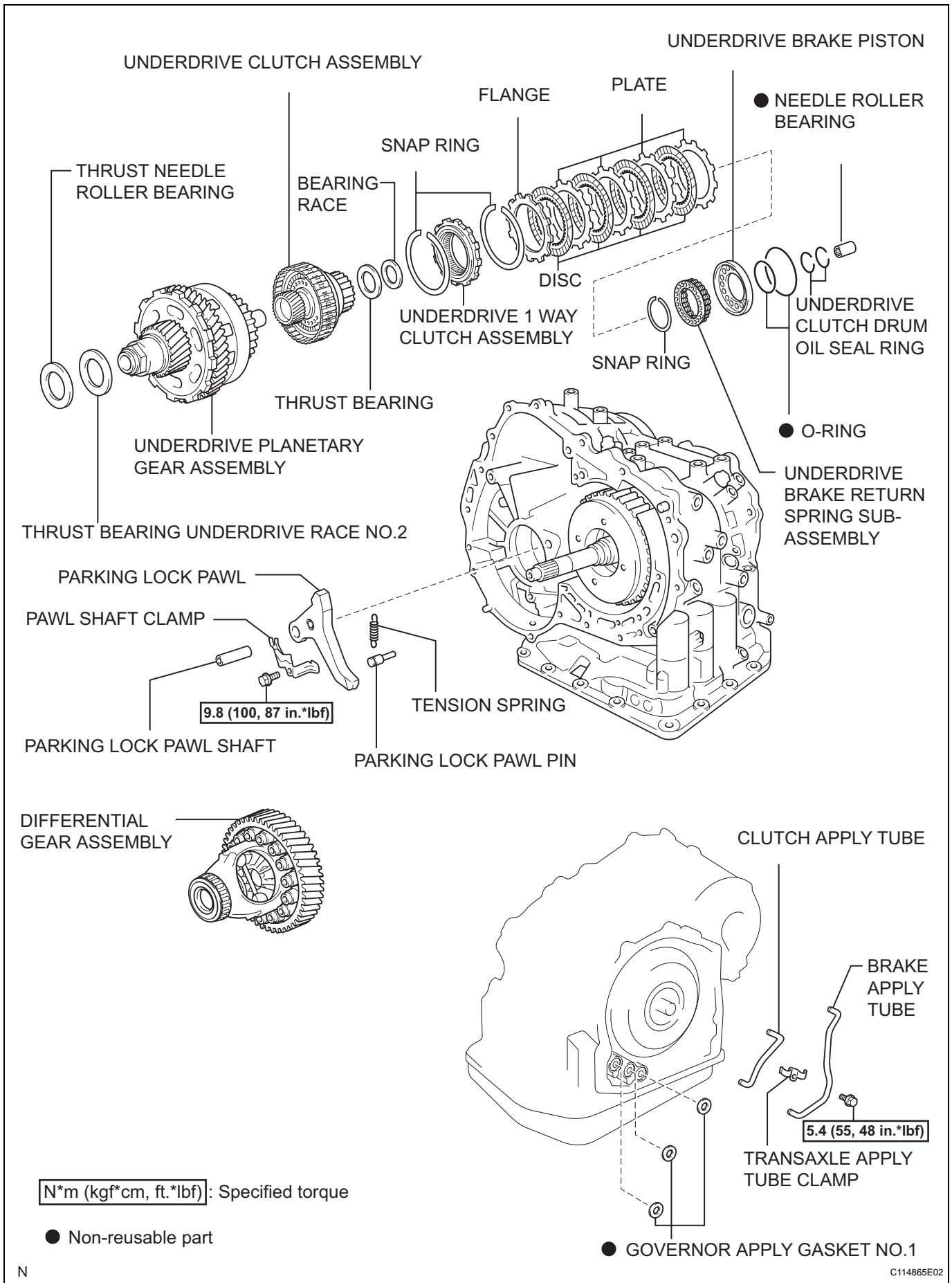

AX