

## REASSEMBLY

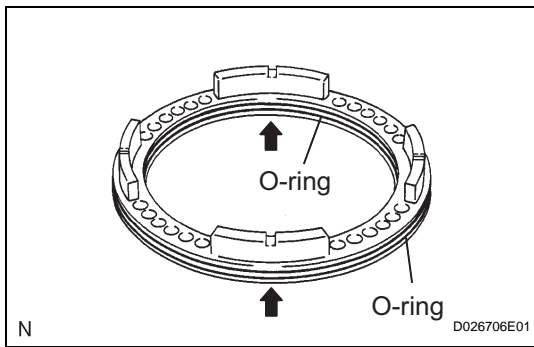

### 1. INSTALL 2ND BRAKE PISTON O-RING

- (a) Coat 2 new O-rings with ATF, and install them in the 2nd brake piston.

**NOTICE:**

**Make sure that the O-ring is not twisted or pinched.**

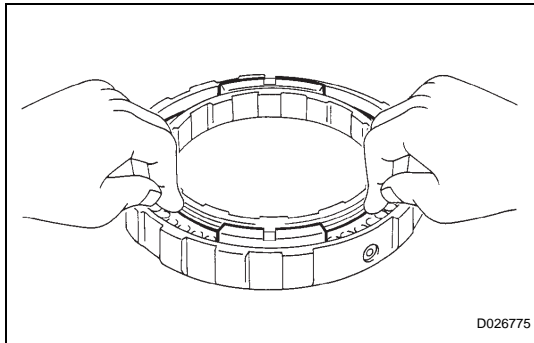

### 2. INSTALL 2ND BRAKE PISTON

- (a) Coat the 2nd brake piston with ATF, and install it to the 2nd brake cylinder.

**NOTICE:**

**Be careful not to damage the O-ring.**

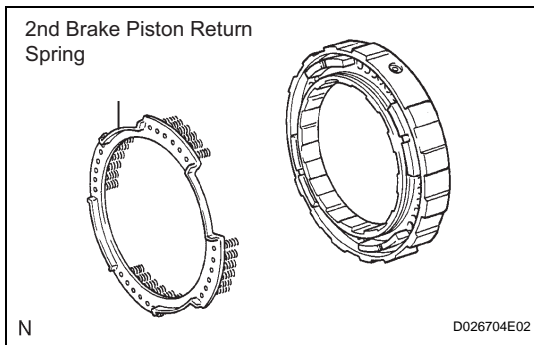

### 3. INSTALL 2ND BRAKE PISTON RETURN SPRING SUB-ASSEMBLY

- (a) Install the 2nd brake piston return spring.

**NOTICE:**

**Installing the spring sub- assembly, check that all of the springs are fit in the piston correctly.**

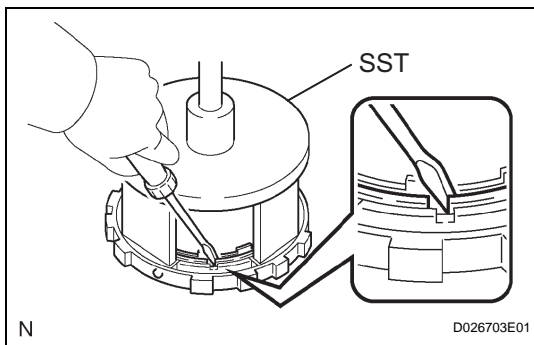

- (b) Place SST on the piston return spring, and compress the piston return spring with a press.

**SST 09387-00060**

- (c) Using a screwdriver, install the snap ring.
- (d) Be sure that the end gap of the snap ring is not aligned with the spring retainer claw.

**NOTICE:**

- Stop the press when the spring seat is lowered to the place 1 to 2 mm (0.039 to 0.078 in.) from the snap ring groove.
- This prevents the spring seat from being deformed.