

REASSEMBLY

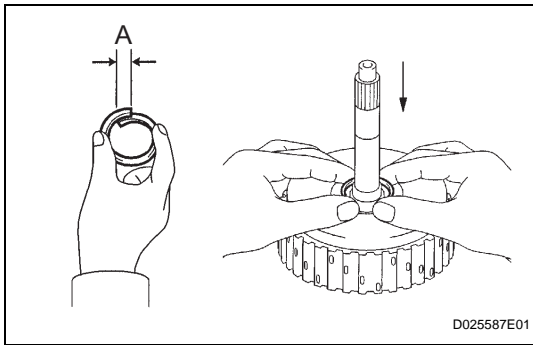

1. INSTALL INPUT SHAFT OIL SEAL RING

- (a) Compress a new input shaft oil seal ring from both sides to reduce dimension A.

Dimension A:
5 mm (0.197 in.)

- (b) Coat the oil seal ring with ATF and install it to the input shaft.

NOTICE:

Do not expand the end gap of the oil seal ring too much. Fix the hooks firmly.

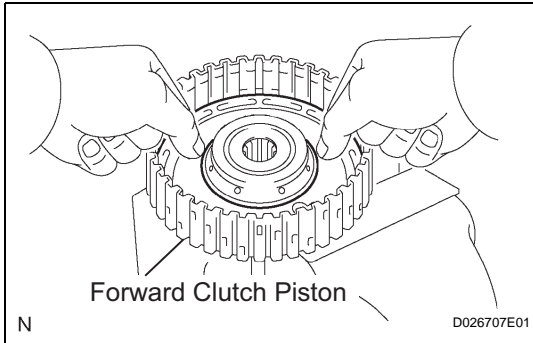

2. INSTALL FORWARD CLUTCH PISTON SUB-ASSEMBLY

- (a) Coat the forward clutch piston with ATF, and install it to the input shaft.

NOTICE:

Be careful not to damage the lip of the forward clutch piston.

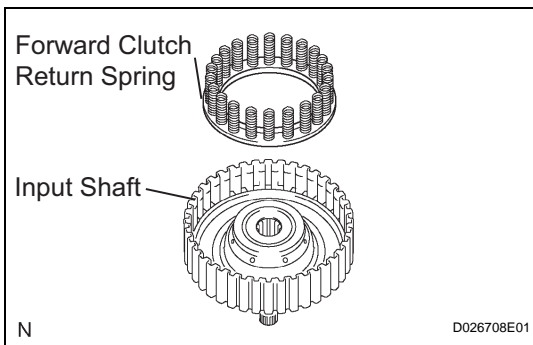

3. INSTALL FORWARD CLUTCH RETURN SPRING SUB-ASSEMBLY

- (a) Install the return spring to the input shaft.

NOTICE:

Installing the spring sub-assembly, check that all of the springs are fit in the piston correctly.

- (b) Coat the clutch balancer with ATF.

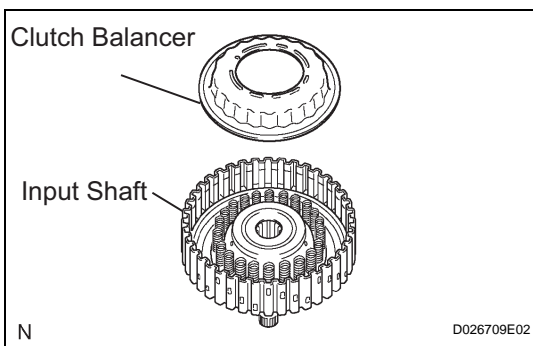

- (c) Install the clutch balancer to the input shaft.

NOTICE:

- **Be careful not to damage the lip of the forward clutch balancer.**
- **Make sure that the clutch balancer is not pinched and that there are no other defects at the lip.**
- **Apply sufficient ATF to the sealing lip before installation.**

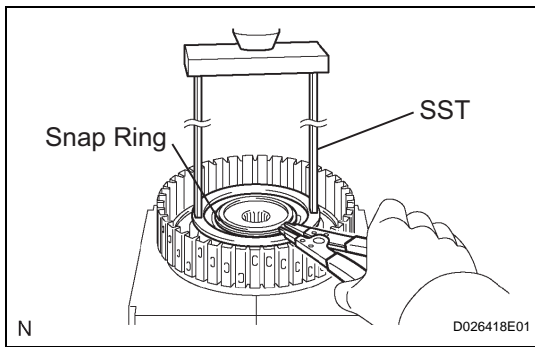

- (d) Place SST on the clutch balancer, and compress the clutch balancer with a press.

SST 09387-00020

- (e) Install the snap ring with a snap ring expander.
- (f) Be sure that the end gap of the snap ring is not aligned with the spring retainer claw.

NOTICE:

- Stop the press when the spring seat is lowered to the place 1 to 2 mm (0.039 to 0.078 in.) from the snap ring groove.
- This prevents the spring seat from being deformed.
- Do not expand the snap ring excessively.

- (g) Set the end gap of the snap ring in the piston as shown in the illustration.

NOTICE:

The end gap of the snap ring should not align with any of the stoppers.

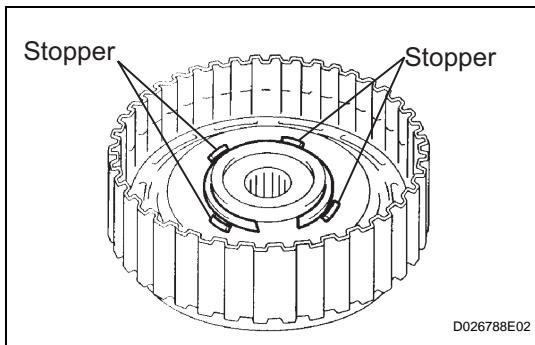

4. INSTALL FORWARD MULTIPLE DISC CLUTCH DISC

- (a) Coat the 5 discs with ATF.

- (b) Install the 5 plates, 5 discs and flange input shaft.

NOTICE:

Make sure that the plates, discs, and flange are installed as shown in the illustration.

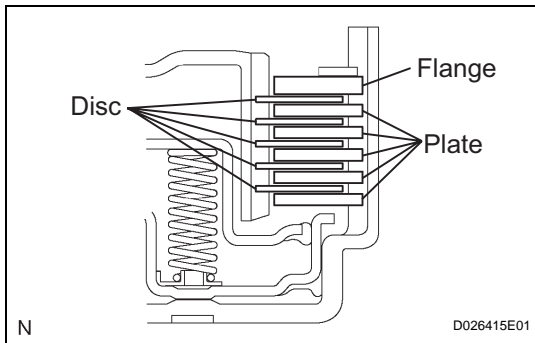

- (c) Using a screwdriver, install the snap ring.
- (d) Check that the end gap of the snap ring is not aligned with one of the cutouts.

NOTICE:

The snap ring should be fully engaged in the groove of the drum.

5. INSPECT PACK CLEARANCE OF FORWARD CLUTCH

HINT:

(See page [AX-262](#))

6. INSPECT FORWARD MULTIPLE DISC CLUTCH DISC

HINT:

(See page [AX-262](#))

