

# UNDERDRIVE PLANETARY GEAR

## COMPONENTS

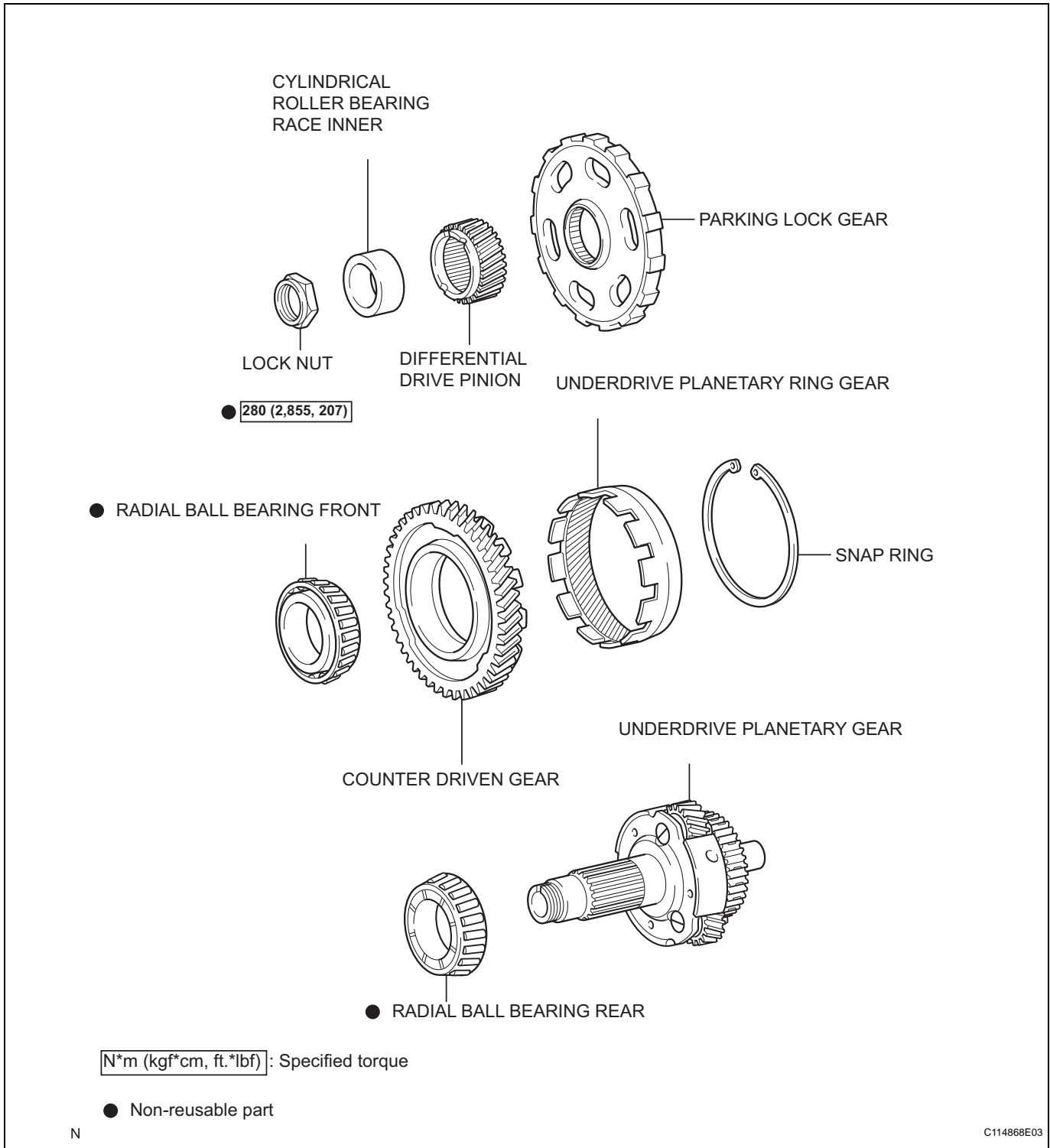

## DISASSEMBLY

### 1. INSPECT UNDERDRIVE PLANETARY GEAR PRELOAD

HINT:

(See page [AX-275](#))

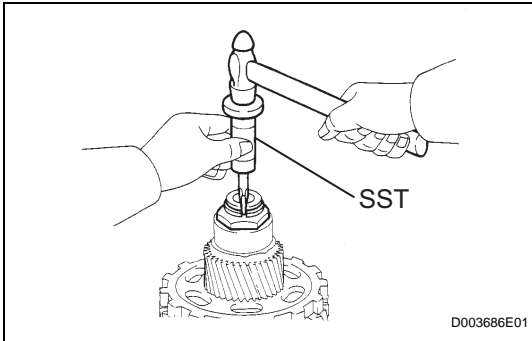

### 2. REMOVE FRONT PLANETARY GEAR NUT

- (a) Using SST, loosen the staked part of the lock nut.  
**SST 09930-00010 (09931-00010, 09931-00020), 09387-00050**

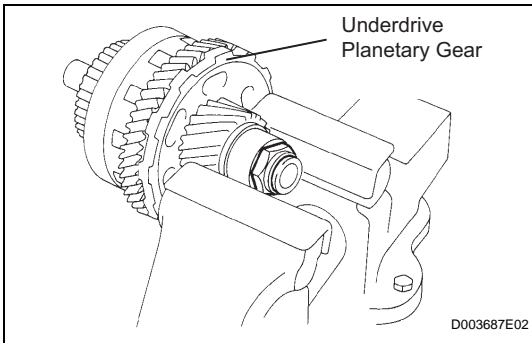

- (b) Place the underdrive planetary gear in a soft jaw vise.

**NOTICE:**

**Be careful not to damage the differential drive pinion.**

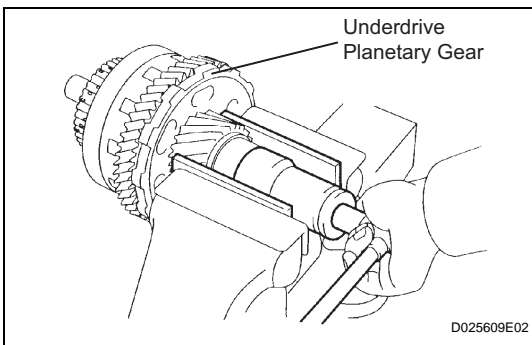

- (c) Using a socket wrench, remove the lock nut.

### 3. REMOVE CYLINDRICAL ROLLER BEARING RACE INNER

- (a) Using SST, remove the cylindrical roller bearing race inner.

**SST 09950-00020, 09950-00030, 09950-60010 (09951-00320, 09957-04010)**

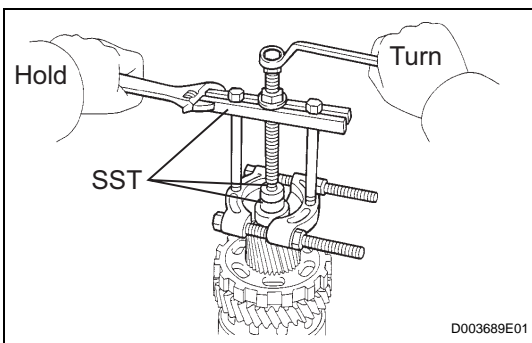

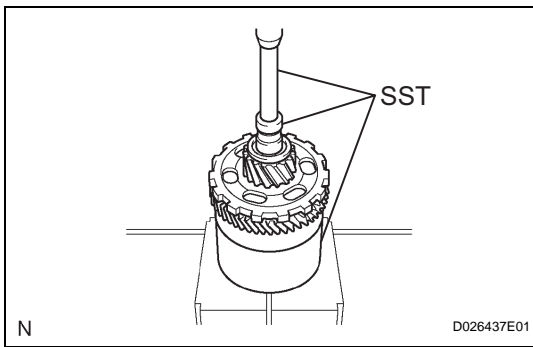

**4. REMOVE UNDERDRIVE PLANETARY GEAR ASSEMBLY**

- (a) Using SST and a press, remove the differential drive pinion, parking lock gear, counter driven gear with underdrive planetary ring gear and radial ball bearing front.

**SST 09950-60010 (09951-00320), 09387-00050, 09950-00020, 09950-00030, 09950-40011 (09957-04010)**

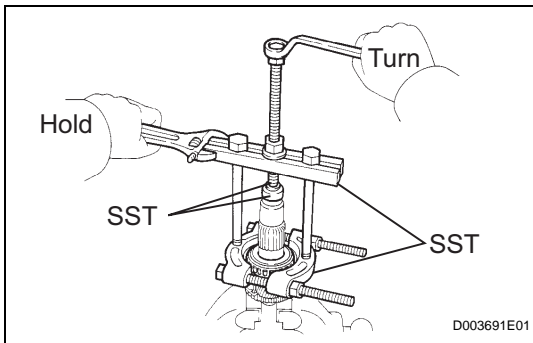

- (b) Place the underdrive planetary gear in a soft jaw vise.
- (c) Using SST, remove the radial ball bearing rear from the underdrive planetary gear.

**SST 09950-60010 (09951-00320), 09950-00030, 09950-40011 (09957-04010)**

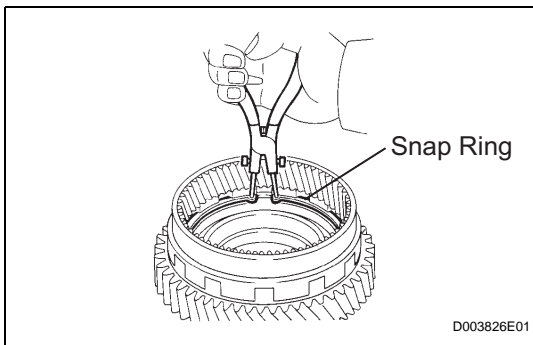

**5. REMOVE UNDERDRIVE PLANETARY RING GEAR**

- (a) Using a snap ring pliers, remove the snap ring.

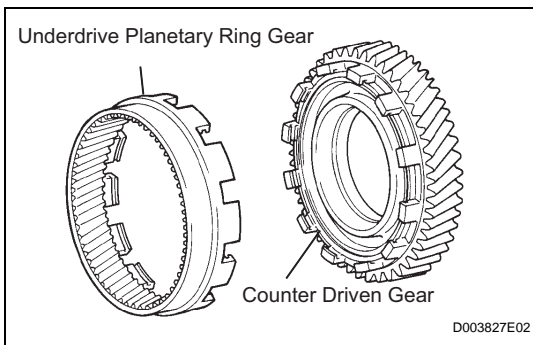

- (b) Remove the underdrive planetary ring gear from the counter driven gear.

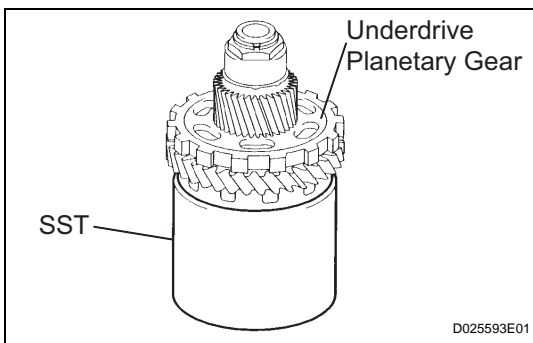

**INSPECTION**

**1. INSPECT UNDERDRIVE PLANETARY GEAR PRELOAD**

- (a) Using SST, fix the underdrive planetary gear assembly.

**SST 09387-00050**

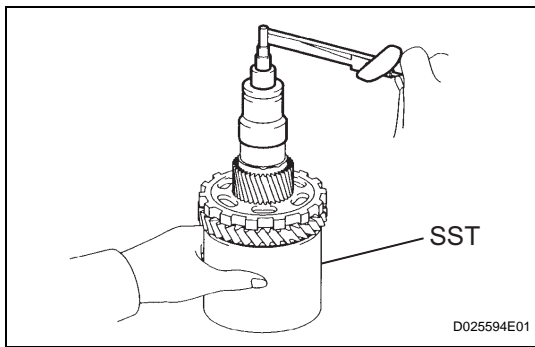

- (b) Using SST and a torque wrench, measure the turning torque of the underdrive planetary gear assembly while rotating the torque wrench at 60 rpm.

**SST 09387-00050**

**Turning torque at 60 rpm.:**

**0.50 to 1.42 N\*m (5.1 to 14.5 kgf\*cm, 4.4 to 12.6 in.\*lbf)**

**HINT:**

Use a torque wrench with a fulcrum length of 160 mm (6.3 in.).

## REASSEMBLY

### 1. INSTALL UNDERDRIVE PLANETARY RING GEAR

- (a) Install a new snap ring to the outer race of the radial ball bearing rear.

**HINT:**

When replacing the bearing, also replace the counter driven gear with a new one.

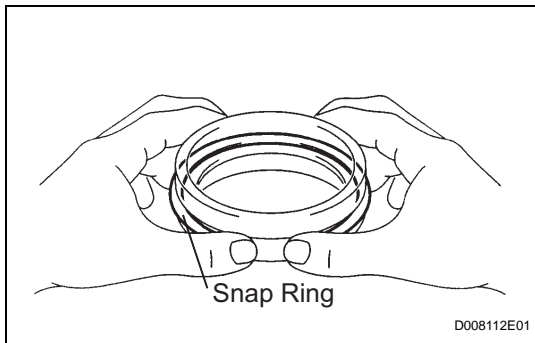

- (b) Using a piston ring compressor, squeeze the snap ring.

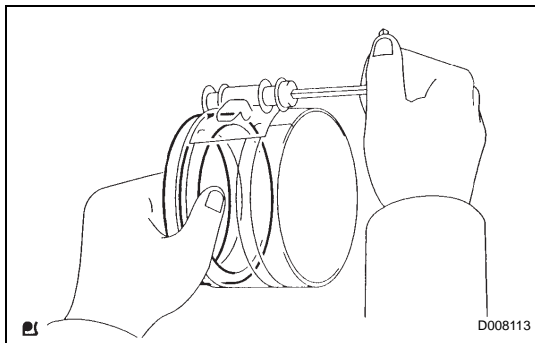

- (c) Using SST and a press, press in the outer race of the radial ball bearing rear.

**SST 09950-60020 (09951-00890), 09950-70010 (09951-07100)**

**NOTICE:**

**Be sure not to damage the snap ring during outer race installation.**

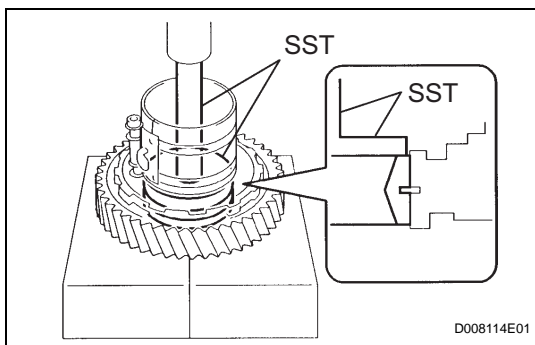

- (d) Install the underdrive planetary ring gear to the counter driven gear.

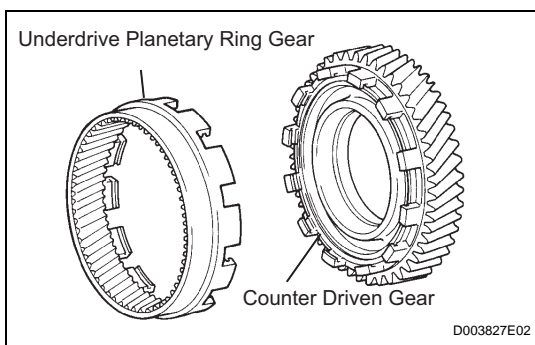

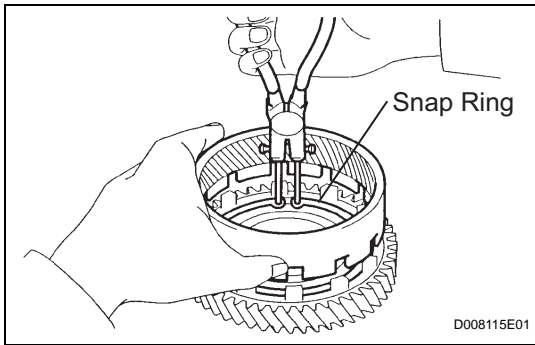

(e) Using a snap ring pliers, install the snap ring.

**2. INSTALL UNDERDRIVE PLANETARY GEAR ASSEMBLY**

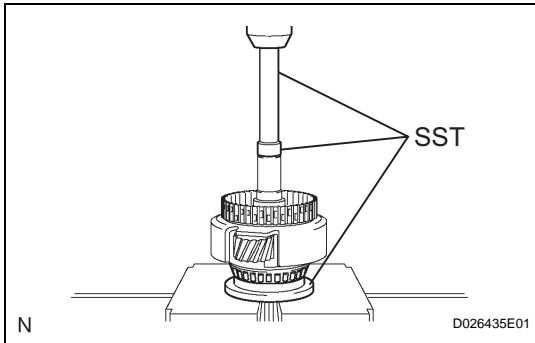

(a) Using SST and a press, press the radial ball bearing rear in the underdrive planetary gear.

**SST 09502-12010, 09950-60010 (09951-00260), 09950-70010 (09951-07100)**

**NOTICE:**

**Press the bearing until it becomes flat at the bottom.**

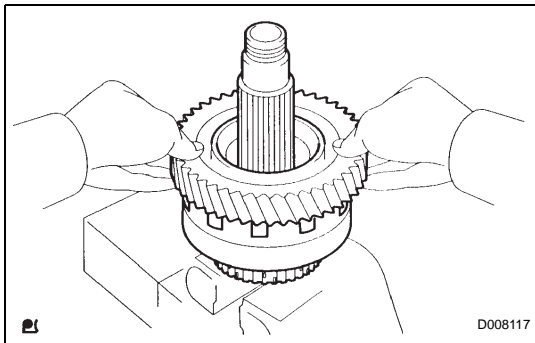

(b) Install the counter driven gear with planetary ring gear to the underdrive planetary gear.

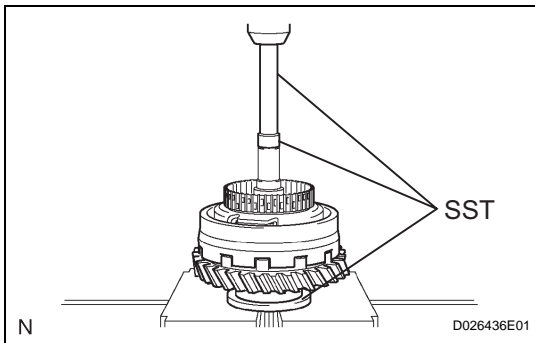

(c) Using SST and a press, press in the radial ball bearing front.

**SST 09502-12010, 09950-60010 (09951-00260), 09950-70010 (09951-07100)**

**NOTICE:**

**Press the counter driven gear while rotating it.**

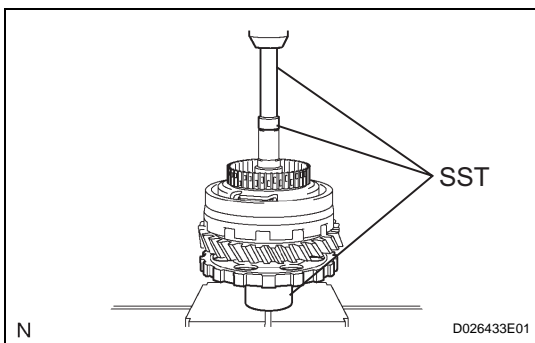

(d) Using SST and a press, press in the parking lock gear.

**SST 09502-12010, 09950-60010 (09951-00260), 09950-70010 (09951-07100)**

**NOTICE:**

**Press the counter driven gear while rotating it.**

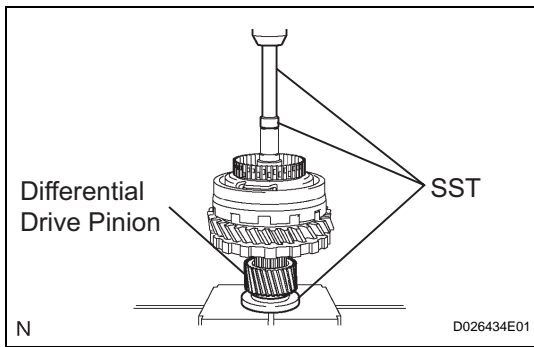

**3. INSTALL DIFFERENTIAL DRIVE PINION**

- (a) Using SST and a press, press the differential drive pinion.  
**SST 09726-40010, 09950-60010 (09951-00260), 09950-70010 (09951-07100)**

**NOTICE:**  
 Press the counter driven gear while rotating it.

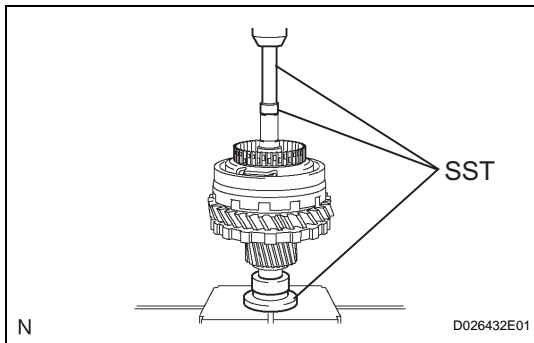

**4. INSTALL CYLINDRICAL ROLLER BEARING RACE INNER**

- (a) Using SST and a press, press the cylindrical roller bearing race inner.  
**SST 09506-35010, 09950-60010 (09951-00260), 09950-70010 (09951-07100)**

**NOTICE:**  
 Press the counter driven gear while rotating it.

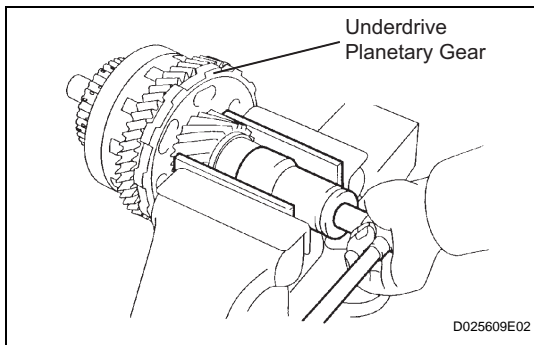

**5. INSTALL FRONT PLANETARY GEAR NUT**

- (a) Place the underdrive planetary gear in a soft jaw vise.

**NOTICE:**  
 Be careful not to damage the differential drive pinion.

- (b) Using a socket wrench, install a new lock nut.  
**Torque: 280 N\*m (2,885 kgf\*cm, 207 ft.\*lbf)**

**HINT:**  
 Use a torque wrench with a fulcrum length of 750 mm (29.53 in.).

- (c) Using a pin punch and hammer, stake the lock nut.

**CAUTION:**  
 Be sure that there are no cracks on the nut.

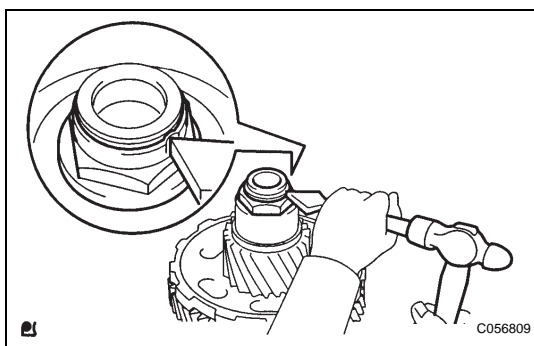

**6. INSPECT UNDERDRIVE PLANETARY GEAR PRELOAD**

**HINT:**  
 (See page [AX-275](#))