

REAR AXLE HUB AND BEARING (for 4WD)

COMPONENTS

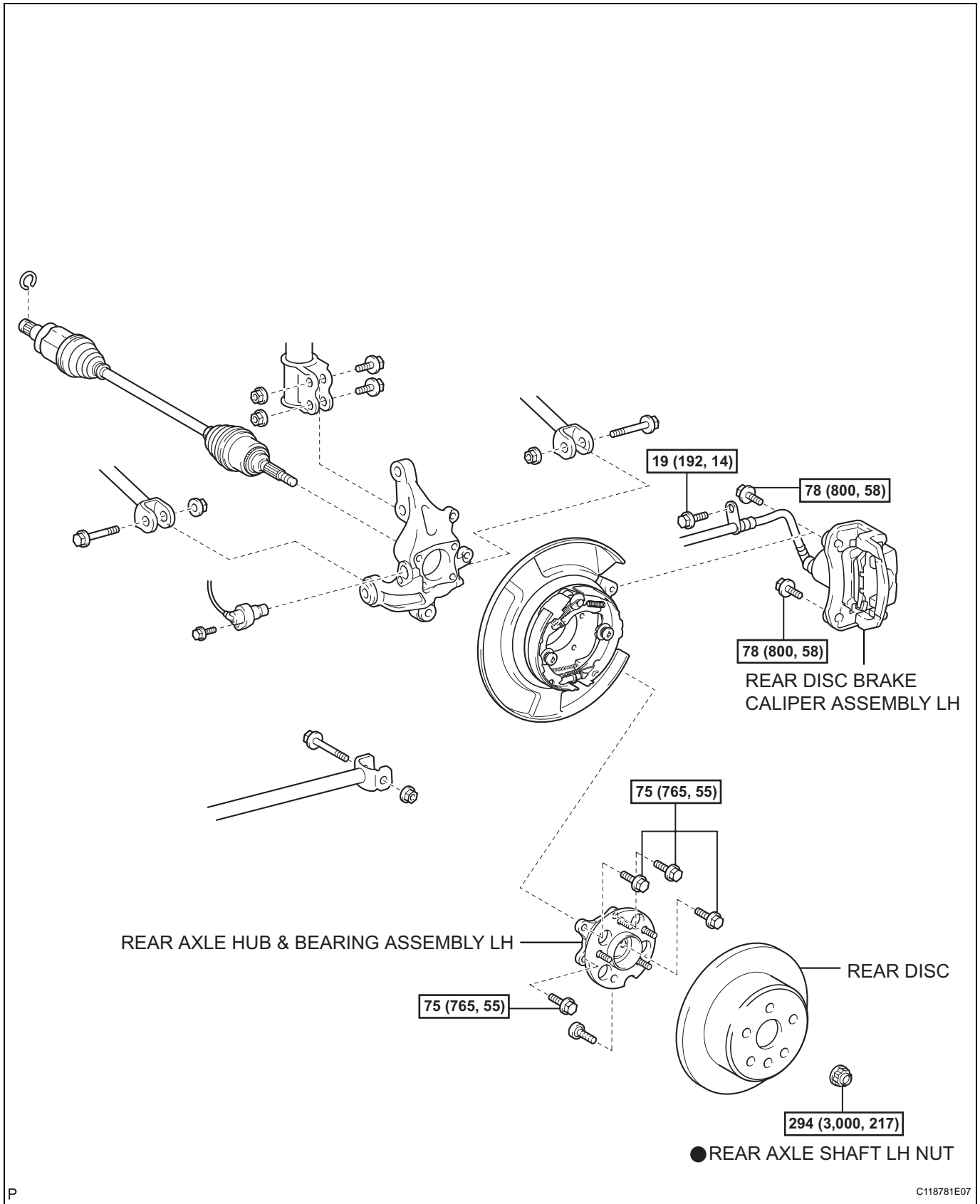

AH

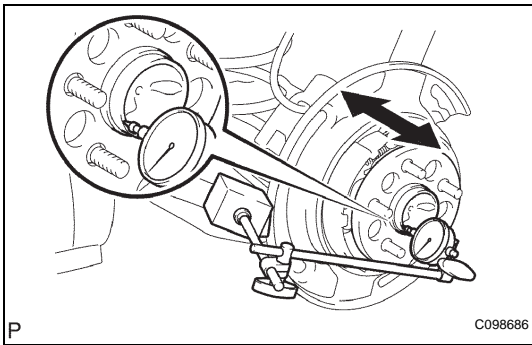

ON-VEHICLE INSPECTION

1. INSPECT REAR AXLE HUB BEARING BACKLASH

- (a) Using a dial gauge, check for backlash near the center of the axle hub.

Maximum:

0.05 mm (0.0020 in.)

If backlash exceeds the maximum, replace the axle hub assembly.

NOTICE:

Ensure that the dial gauge is set at right angles to the measurement surface.

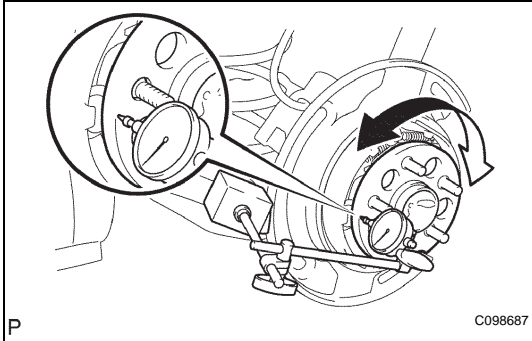

2. INSPECT REAR AXLE HUB BEARING DEVIATION

- (a) Using a dial gauge, check for deviation in the surface of the axle hub outside the hub bolt.

Maximum:

0.08 mm (0.0031 in.)

If backlash exceeds the maximum, replace the axle hub assembly.

NOTICE:

Ensure that the dial gauge is set at right angles to the measurement surface.