

DTC	C0226/21	SFR Solenoid Circuit
DTC	C0236/22	SFL Solenoid Circuit
DTC	C0246/23	SRR Solenoid Circuit
DTC	C0256/24	SRL Solenoid Circuit
DTC	C1225/25	SM Solenoid Circuit

DESCRIPTION

This solenoid goes on when signals are received from the ECU and controls the pressure acting on the wheel cylinders to control the braking force.

DTC No.	DTC Detection Condition	Trouble Area
C0226/21	Open or short circuit in front right solenoid circuit (SFRR or SFRH) continues for 0.05 sec. or more.	<ul style="list-style-type: none"> • ABS & TRAC actuator • Each solenoid circuit
C0236/22	Open or short circuit in front left solenoid circuit (SFLR or SFLH) continues for 0.05 sec. or more.	<ul style="list-style-type: none"> • ABS & TRAC actuator • Each solenoid circuit
C0246/23	Open or short circuit in rear right solenoid circuit (SRRR or SRRH) continues for 0.05 sec. or more.	<ul style="list-style-type: none"> • ABS & TRAC actuator • Each solenoid circuit
C0256/24	Open or short circuit in rear left solenoid circuit (SRLR or SRLH) continues for 0.05 sec. or more.	<ul style="list-style-type: none"> • ABS & TRAC actuator • Each solenoid circuit
C1225/25	<p>When any of the following (1 to 5) is detected:</p> <ol style="list-style-type: none"> All the following conditions continues for at least 0.05 seconds. <ul style="list-style-type: none"> – When switching solenoid (SM1 or SM2) outputs ON signal. – Over current. All the following conditions continues for at least 0.05 seconds. <ul style="list-style-type: none"> – When switching solenoid (SM1 or SM2) outputs OFF signal. – Open circuit. All the following conditions continue for at least 0.05 seconds. <ul style="list-style-type: none"> – When switching solenoid (SM1 or SM2) outputs OFF signal. – Output current monitor is more than 0.15 A. All the following conditions continues for at least 0.05 seconds. <ul style="list-style-type: none"> – When switching solenoid (SM1 or SM2) outputs ON signal. – Output current is more than 0.348 A. – Difference between current monitor and target value exceeds 2, continues for between 0.1 sec. and 0.15 sec. All the following conditions continue for at least 0.2 seconds. <ul style="list-style-type: none"> – When switching solenoid (SM1 or SM2) outputs ON signal. – Output current is more than 0.348 A. – Switching solenoid (SM1 or SM2) duty ratio: <ol style="list-style-type: none"> (1) More than 2.08 (2) Less than 0.48 	<ul style="list-style-type: none"> • ABS & TRAC actuator • Each solenoid circuit

WIRING DIAGRAM

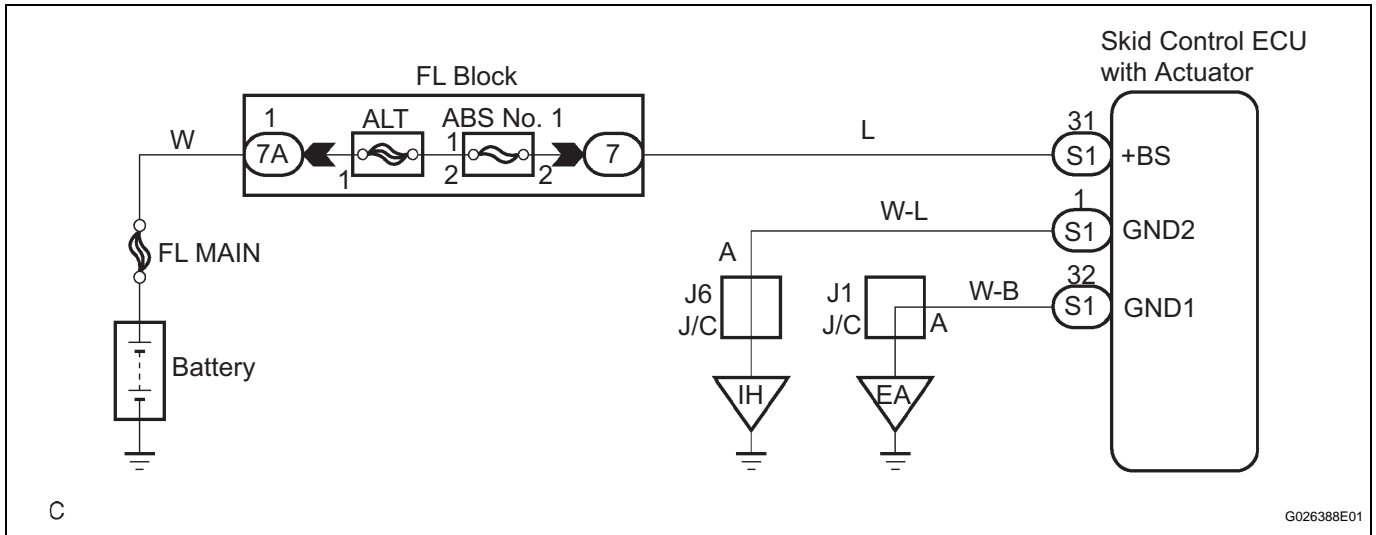

1 RECONFIRM DTC

HINT:

This code is detected when a problem is determined in the ABS & TRACTION actuator assembly.

The solenoid circuit is in the ABS & TRACTION actuator assembly.

Therefore, solenoid circuit inspection and solenoid unit inspection cannot be performed. Be sure to check if the DTC code is output before replacing the ABS & TRACTION actuator assembly.

- (a) Clear the DTCs (See page BC-21).
- (b) Turn the ignition switch to the ON position.
- (c) Are the same DTCs recorded?

Result

Result	Proceed to
DTC is output	A
DTC is not output	B

NOTICE:

When replacing the ABS & TRACTION actuator assembly, perform zero point calibration (See page BC-5).

B → **PROCEED TO NEXT CIRCUIT INSPECTION SHOWN IN PROBLEM SYMPTOMS TABLE**

A

REPLACE ABS AND TRACTION ACTUATOR