

# ABS Warning Light Remains ON

## DESCRIPTION

If either of following is detected, the ABS warning light remains on.

- Voltage of ECU terminal IG1 remains at more than 17 V.
- There is a malfunction in the ECU internal circuit.

## WIRING DIAGRAM

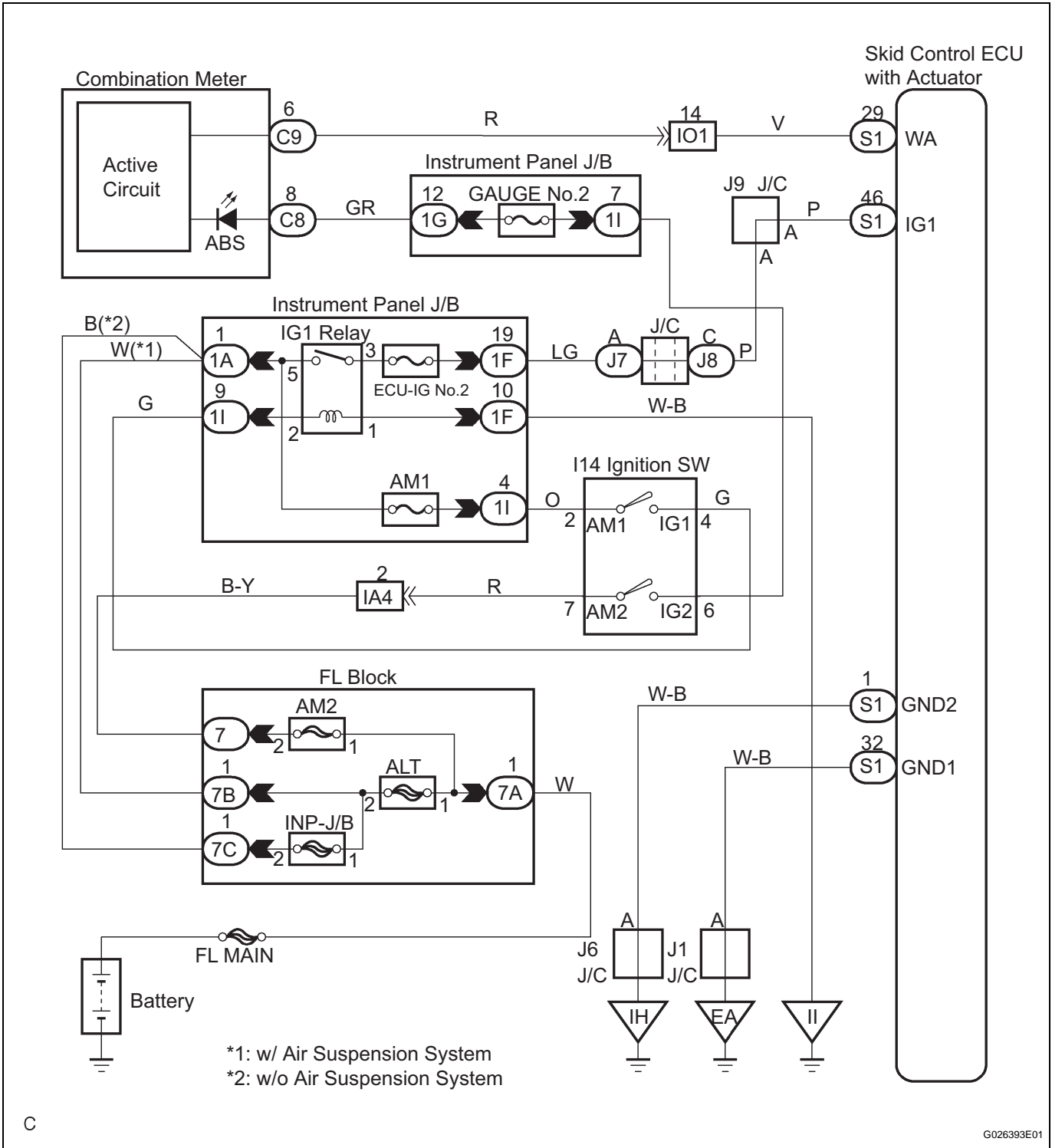

**1 CHECK DTC OUTPUT**

(a) Is DTC output for ABS.

**Result**

Result	Proceed to
DTC is not output	A
DTC is output	B

**B****REPAIR CIRCUITS INDICATED BY OUTPUT DTCS****A****2 INSPECT SKID CONTROL ECU CONNECTOR**

(a) Check the ECU connector's connecting condition.

**OK:****The connector should be securely connected.****NG****CONNECT CONNECTOR CORRECTLY****OK****3 INSPECT BATTERY**

(a) Check the battery voltage.

**Voltage:****11 to 14 V****NG****INSPECT CHARGING SYSTEM****OK****4 INSPECT SKID CONTROL ECU TERMINAL VOLTAGE (IG1 TERMINAL)**

(a) WHEN USING INTELLIGENT TESTER:

- (1) Connect the intelligent tester to the DLC3.
- (2) Start the engine.
- (3) Select the DATA LIST mode on the intelligent tester.

Item	Measurement Item / Range (Display)	Normal Condition
IG VOLTAGE	ECU power supply voltage / UNDER / NORMAL	NORMAL: 9.5 V or over UNDER: Below 9.5 V

(4) Read the voltage condition output from the ECU displayed on the intelligent tester.

**OK:****"Normal" is displayed.**

(b) WHEN NOT USING INTELLIGENT TESTER:

- (1) Disconnect the skid control ECU connector.
- (2) Turn the ignition switch ON position.

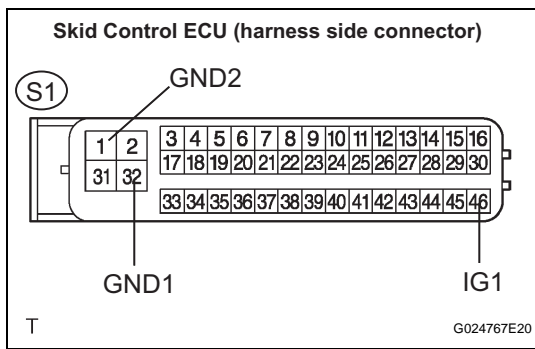

(3) Measure the voltage according to the value(s) in the table below.

**Voltage**

Tester Connection	Specified Condition
S1-46 (IG1) - S1-32 (GND1)	10 to 14 V
S1-46 (IG1) - S1-1 (GND2)	10 to 14 V

**NG** → **Go to step 6**

**OK**

**5 INSPECT ABS WARNING LIGHT**

- (a) WHEN USING INTELLIGENT TESTER:
  - (1) Connect the intelligent tester to the DLC3 and start the engine.
  - (2) Select the item "ABS WARN LIGHT" in the ACTIVE TEST and operate the ABS warning light on the intelligent tester.
  - (3) Check that "ON" and "OFF" of the ABS warning light can be shown on the combination meter by the intelligent tester.
- (b) WHEN NOT USING INTELLIGENT TESTER:
  - (1) Turn the ignition switch off and disconnect the connector S1 from the skid control ECU.
  - (2) Ground the terminal WA of the skid control ECU.
  - (3) Turn the ignition switch to the ON position.
  - (4) Check that the ABS warning light goes off.

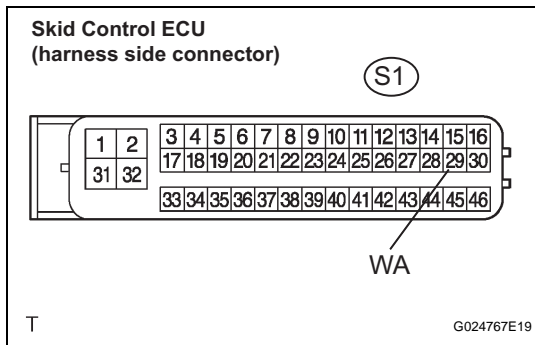

**OK** → **REPAIR OR REPLACE ABS WARNING LIGHT CIRCUIT**

**NG**

**REPLACE ABS AND TRACTION ACTUATOR**

**6 CHECK HARNESS AND CONNECTOR (SKID CONTROL ECU - BODY GROUND)**

- (a) Disconnect the skid control ECU connector.

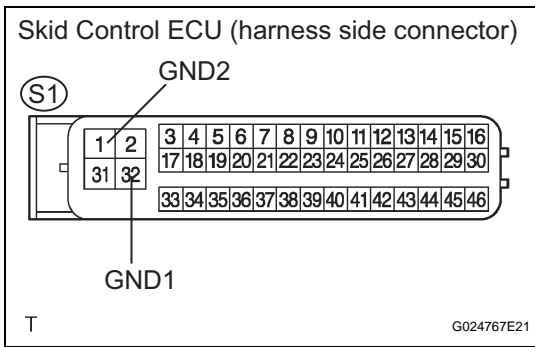

(b) Measure the resistance according to the value(s) in the table below.

**Resistance**

Tester Connection	Specified Condition
S1-1 (GND2) - Body ground	Below 1 Ω
S1-32 (GND1) - Body ground	Below 1 Ω

**NOTICE:**

When replacing ABS & TRACTION actuator assembly, perform zero point calibration (See page [BC-5](#)).

**NG** REPAIR OR REPLACE HARNESS OR CONNECTOR

**OK**

REPLACE ABS AND TRACTION ACTUATOR