

REMOVAL

1. DRAIN BRAKE FLUID

NOTICE:

Wash the brake fluid off immediately if it adheres to any painted surfaces.

2. REMOVE V-BANK COVER SUB-ASSEMBLY (See page [EM-113](#))

3. REMOVE AIR CLEANER ASSEMBLY

4. REMOVE AIR CLEANER HOSE NO.1

5. REMOVE BRAKE MASTER CYLINDER SUB-ASSEMBLY

HINT:

See page [BR-14](#).

SST 09023-00101

6. REMOVE FRONT WIPER ARM AND BLADE ASSEMBLY RH (See page [WW-37](#))

7. REMOVE FRONT WIPER ARM AND BLADE ASSEMBLY LH (See page [WW-37](#))

8. REMOVE FRONT FENDER TO COWL SIDE SEAL RH

9. REMOVE FRONT FENDER TO COWL SIDE SEAL LH

10. REMOVE COWL TOP VENTILATOR LOUVER SUB-ASSEMBLY

11. REMOVE WINDSHIELD WIPER MOTOR & LINK ASSEMBLY

12. REMOVE FRONT SHOCK ABSORBER CAP RH

13. REMOVE FRONT SHOCK ABSORBER CAP LH (See page [SP-16](#))

14. REMOVE COWL TOP PANEL SUB-ASSEMBLY OUTER

15. REMOVE BRAKE PEDAL RETURN SPRING

(a) Remove the brake pedal return spring.

16. REMOVE BRAKE MASTER CYLINDER PUSH ROD CLEVIS

(a) Remove the clip and the push rod pin.

(b) Loosen the push rod lock nut and remove the push rod clevis.

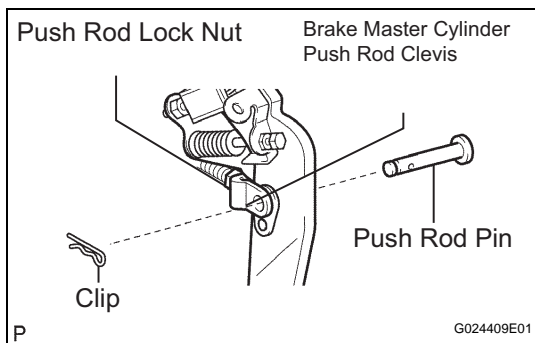

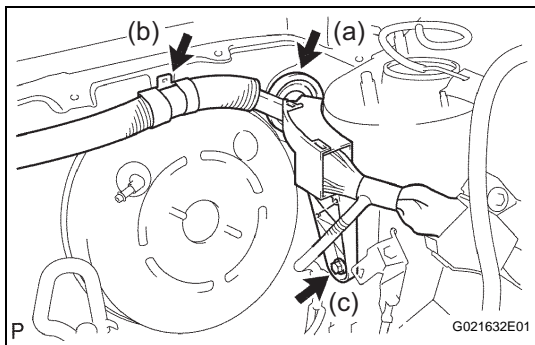
**17. SEPARATE WIRE HARNESS**

- (a) Pull out the grommet of the wire harness from the body.
- (b) Release the clip fitting of the wire harness.
- (c) Remove the bolt and separate the wire harness from the body.

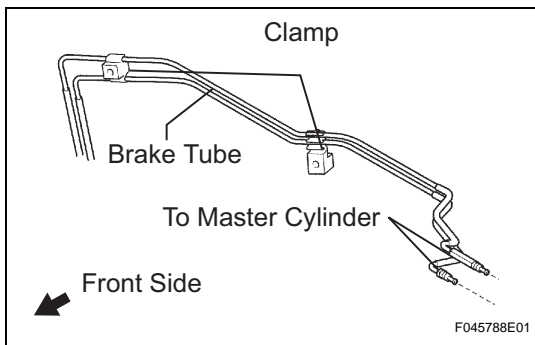
**18. SEPARATE BRAKE TUBE**

- (a) Release the 2 claw fittings of the clamp and separate the 2 brake tubes from the body.

NOTICE:

Be careful not to damage the brake tubes.

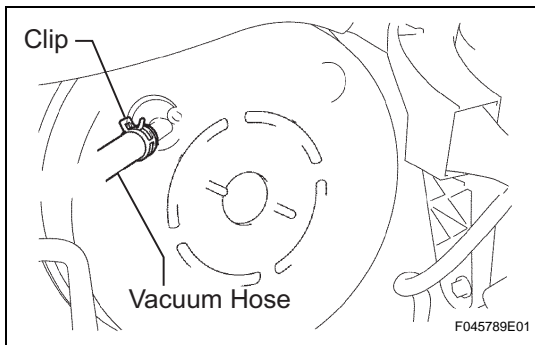
**19. REMOVE BRAKE BOOSTER ASSEMBLY**

- (a) Slide the clip and disconnect the vacuum hose from the check valve assembly.

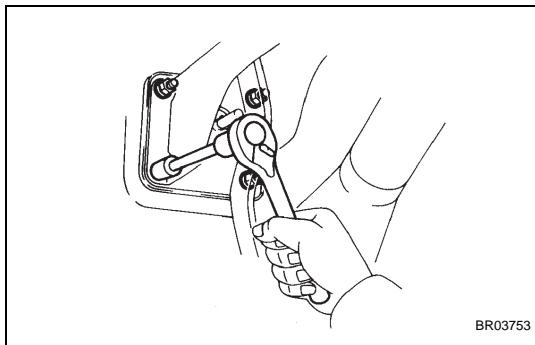

- (b) Remove the 4 nuts and pull out the brake booster assembly.

NOTICE:

Be careful not to damage the brake tubes and the wire harness.

20. REMOVE BRAKE BOOSTER GASKET

- (a) Remove the brake booster gasket from the brake booster assembly.

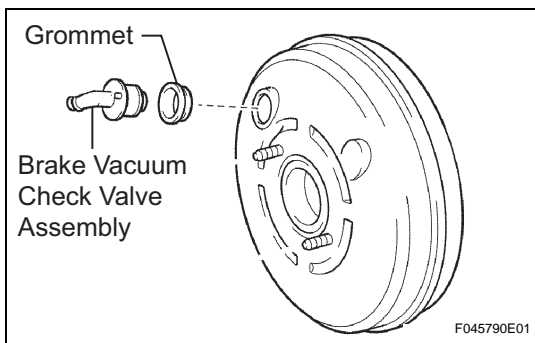
**21. REMOVE BRAKE VACUUM CHECK VALVE ASSEMBLY**

- (a) Remove the check valve assembly and the grommet from the brake booster assembly.