

## Rear Door UNLOCK Detection Switch LH Circuit

### DESCRIPTION

The rear left side door unlock detection switch is built into the rear left side door lock assembly. The switch turns on when the rear left side door is locked and turns off when the door is unlocked.

The body ECU is connected to the rear left side door lock assembly via terminal LSWL and rear left side door lock/unlock state signals are input to the ECU.

The body ECU applies voltage to the door unlock detection switch via terminal LSWL. When the door unlock detection switch is on (there is continuity between the switch terminals), a lock state signal is input to the ECU. When the switch is off (there is no continuity between the switch terminals), an unlock state signal is input.

### WIRING DIAGRAM

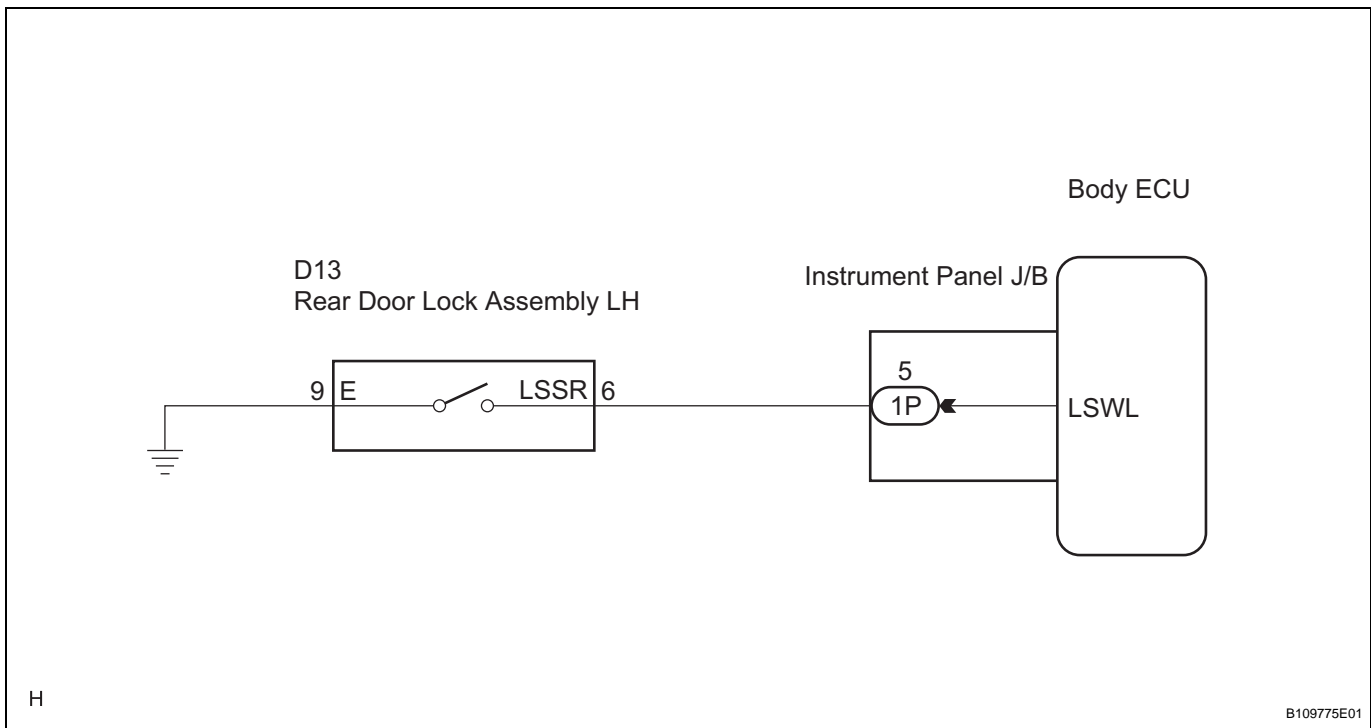

### 1 READ VALUE OF DATA LIST (UNLOCK DETECTION SWITCH)

- (a) Check the DATA LIST to ensure proper function of the door unlock detection switch.

#### BODY:

Item	Measurement Item / Display (Range)	Normal Condition	Diagnostic Note
Rr LOCK POS SW	Rear door lock position switch signal /ON or OFF	ON: Rear door lock is in UNLOCK position OFF: Rear door lock is in LOCK position	-

#### OK:

The display is as specified in the normal condition.

NG

Go to step 2

OK

PROCEED TO NEXT CIRCUIT INSPECTION SHOWN IN PROBLEM SYMPTOMS TABLE

**2 INSPECT REAR DOOR LOCK ASSEMBLY (UNLOCK DETECTION SWITCH)**

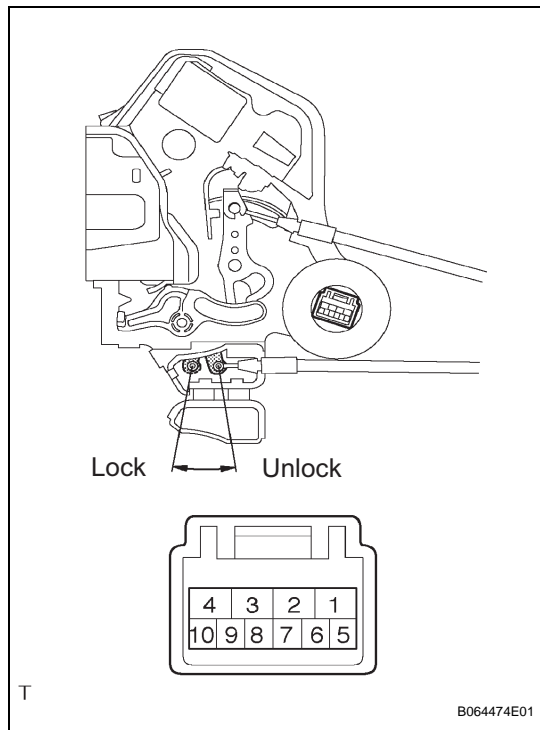

- (a) Remove the rear door lock assembly.
- (b) Measure the resistance according to the value(s) in the table below.

**Standard resistance**

Measurement Condition	Door Lock Condition	Specified Condition
Battery positive (+) → Terminal 4 Battery negative (-) → Terminal 1	Lock	6 - 9 (10 kΩ or higher)
Battery positive (+) → Terminal 1 Battery negative (-) → Terminal 4	Unlock	6 - 9 (Below 1 Ω)

NG → REPLACE REAR DOOR LOCK ASSEMBLY

OK

DL

### 3 CHECK WIRE HARNESS (REAR DOOR LOCK ASSEMBLY - INSTRUMENT PANEL J/B (BODY ECU))

#### Wire Harness Side:

D13  
Rear Door Lock Assembly LH

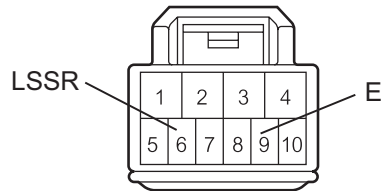

1P  
Instrument Panel J/B (Body ECU)

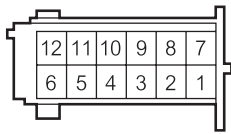

H

B111700E01

- Disconnect the rear door lock assembly connector.
- Disconnect the instrument panel J/B connector.
- Measure the resistance according to the value(s) in the table below.

#### Standard resistance

Tester Connection	Condition	Specified Condition
D13-6 (LSSR) - 1P-5	Always	Below 1 $\Omega$
D13-9 (E) - Body ground	Always	Below 1 $\Omega$

**NG**

**REPAIR OR REPLACE HARNESS OR CONNECTOR**

**OK**

**PROCEED TO NEXT CIRCUIT INSPECTION SHOWN IN PROBLEM SYMPTOMS TABLE**