

## DIAGNOSIS SYSTEM

### 1. DESCRIPTION

The ECU stores trouble codes when trouble occurs on the vehicle.

The diagnostic system allows for reading of the trouble codes from the DLC3.

Use the intelligent tester to check and solve the problem.

### 2. CHECK DLC3

(a) The vehicle's ECU uses ISO 9141-2 for communication.

The terminal arrangement of the DLC3 complies with SAE J1962 and matches the ISO 9141-2 format.

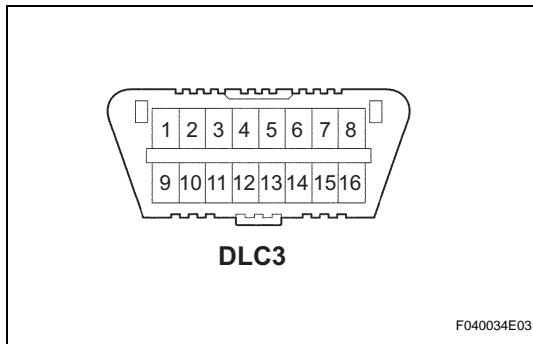

Symbols (Terminal No.)	Terminal Description	Condition	Specified Condition
SIL (7) - SG (5)	Bus "+" line	During transmission	Pulse generation
CG (4) - Body ground	Chassis ground	Always	Below 1 $\Omega$
SG (5) - Body ground	Signal ground	Always	Below 1 $\Omega$
BAT (16) - Body ground	Battery positive	Always	11 to 14 V
CANH (6) - CANL (14)	HIGH-level CAN bus line	Ignition switch OFF	54 to 67 $\Omega$
CANH (6) - Battery positive	HIGH-level CAN bus line	Ignition switch OFF	1 M $\Omega$ or higher
CANH (6) - CG (4)	HIGH-level CAN bus line	Ignition switch OFF	3 k $\Omega$ or higher
CANL (14) - Battery positive	LOW-level CAN bus line	Ignition switch OFF	1 M $\Omega$ or higher
CANL (14) - CG (4)	LOW-level CAN bus line	Ignition switch OFF	3 k $\Omega$ or higher

#### HINT:

If the display shows a communication error message after connecting the intelligent tester to the DLC3 and turning the ignition switch to the ON position, there is a problem with either the vehicle or the intelligent tester.

- If communication is normal when the tester is connected to another vehicle, inspect the DLC3 on the original vehicle.
- If communication is still impossible when the tester is connected to another vehicle, the problem is probably in the tester itself. Consult the Service Department listed in the tester's operator's manual.

## DTC CHECK / CLEAR

### 1. CHECK DTC

- Connect the intelligent tester to the DLC3.
- Turn the ignition switch ON.
- Read the DTC by following the prompts on the tester screen.

#### HINT:

Refer to the intelligent tester operator's manual for further details.

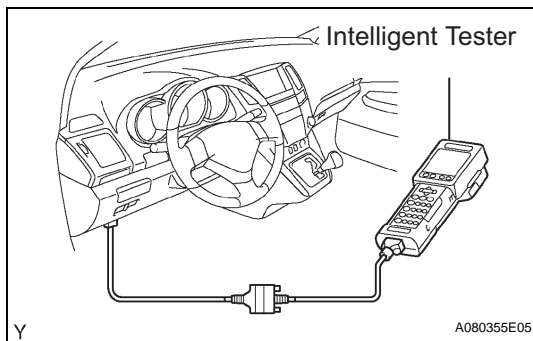

**2. CLEAR DTC**

- (a) Connect the intelligent tester to the DLC3.
- (b) Turn the ignition switch ON.
- (c) Erase the DTC by following the directions on the tester screen.

**HINT:**

Refer to the intelligent tester operator's manual for further details.