

ENGINE REAR OIL SEAL

COMPONENTS

EM

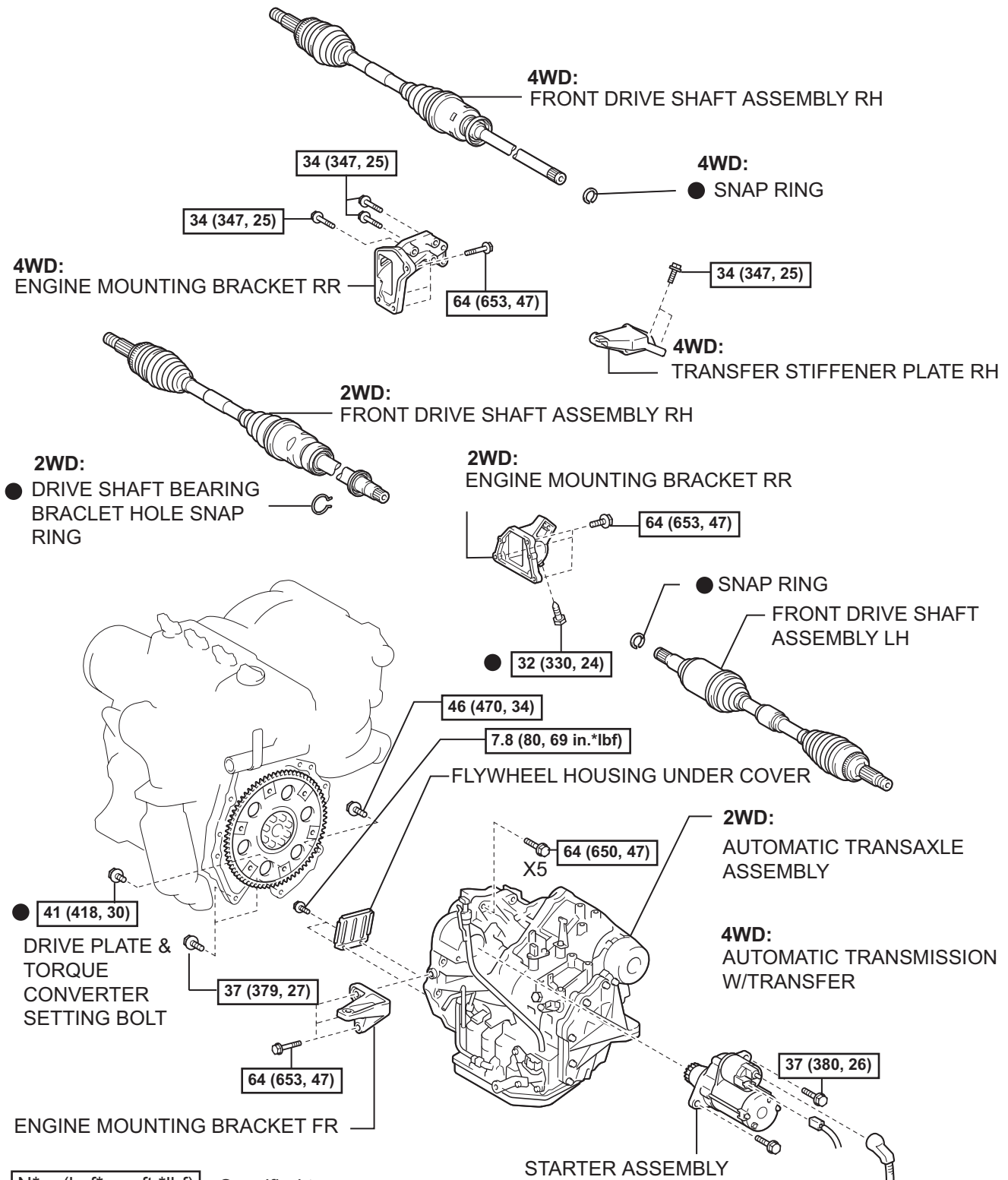

N*m (kgf*cm, ft.*lbf) : Specified torque

● Non-reusable part

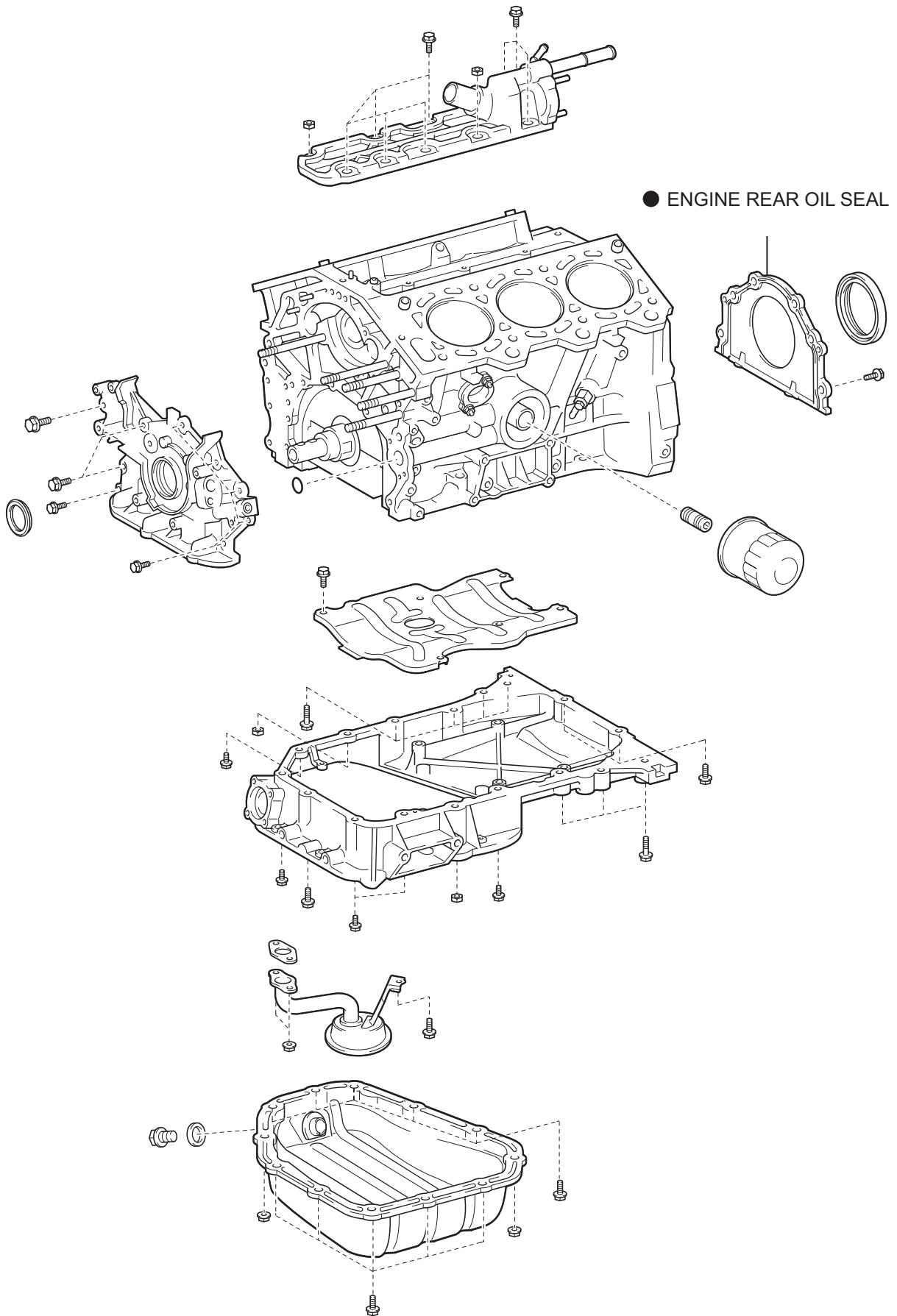

EM

P ● Non-reusable part