

ENGINE ASSEMBLY

COMPONENTS

EM

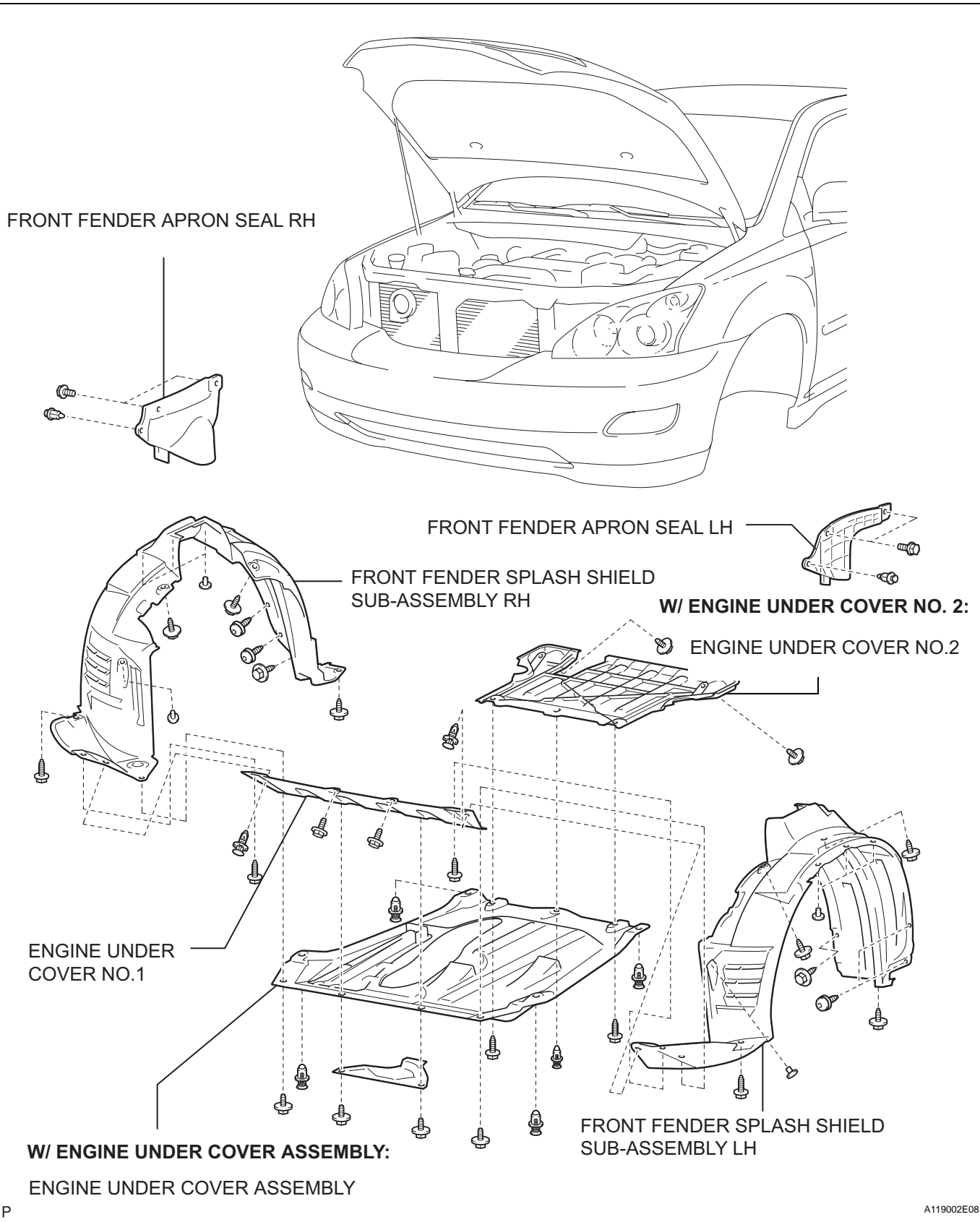

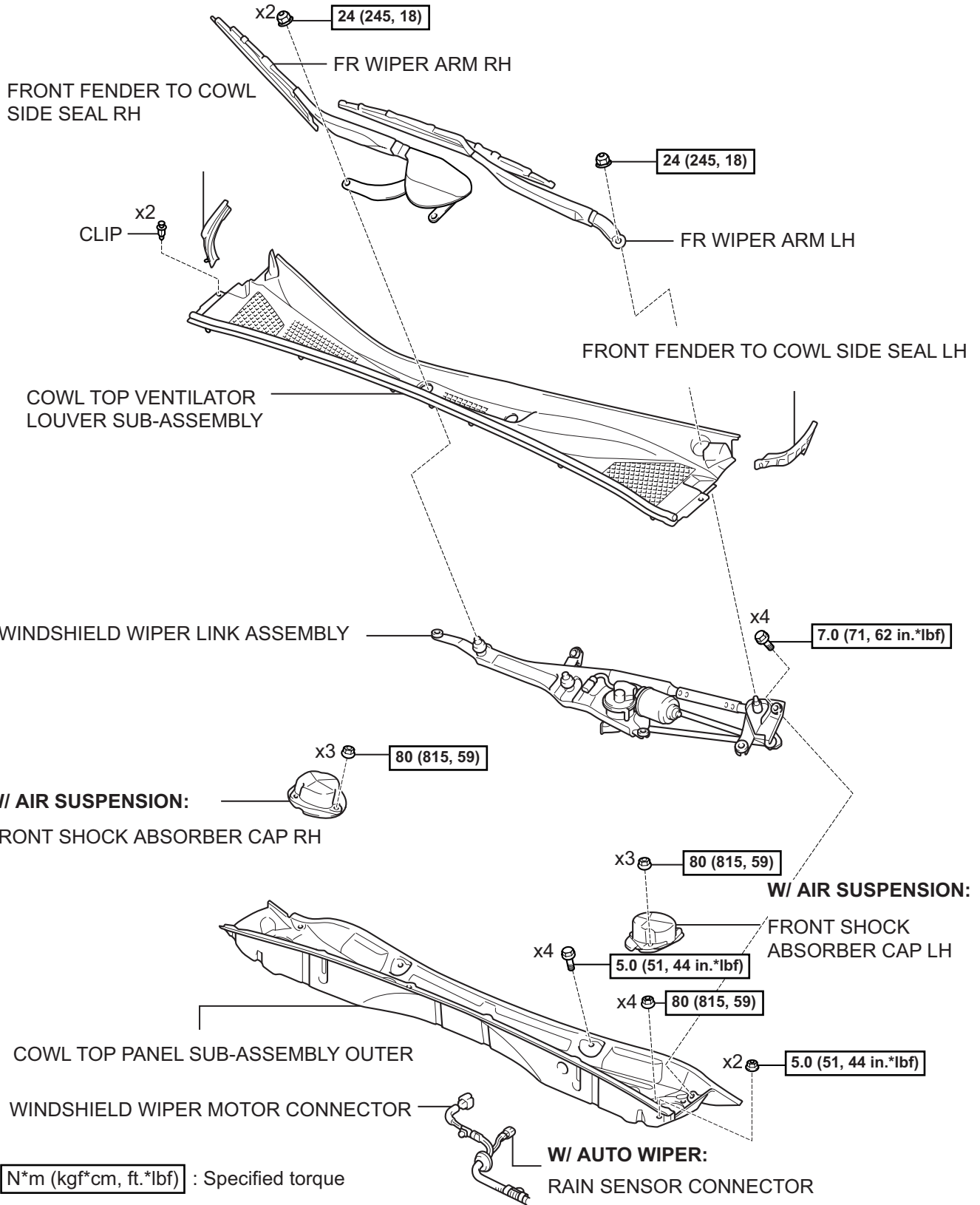

EM

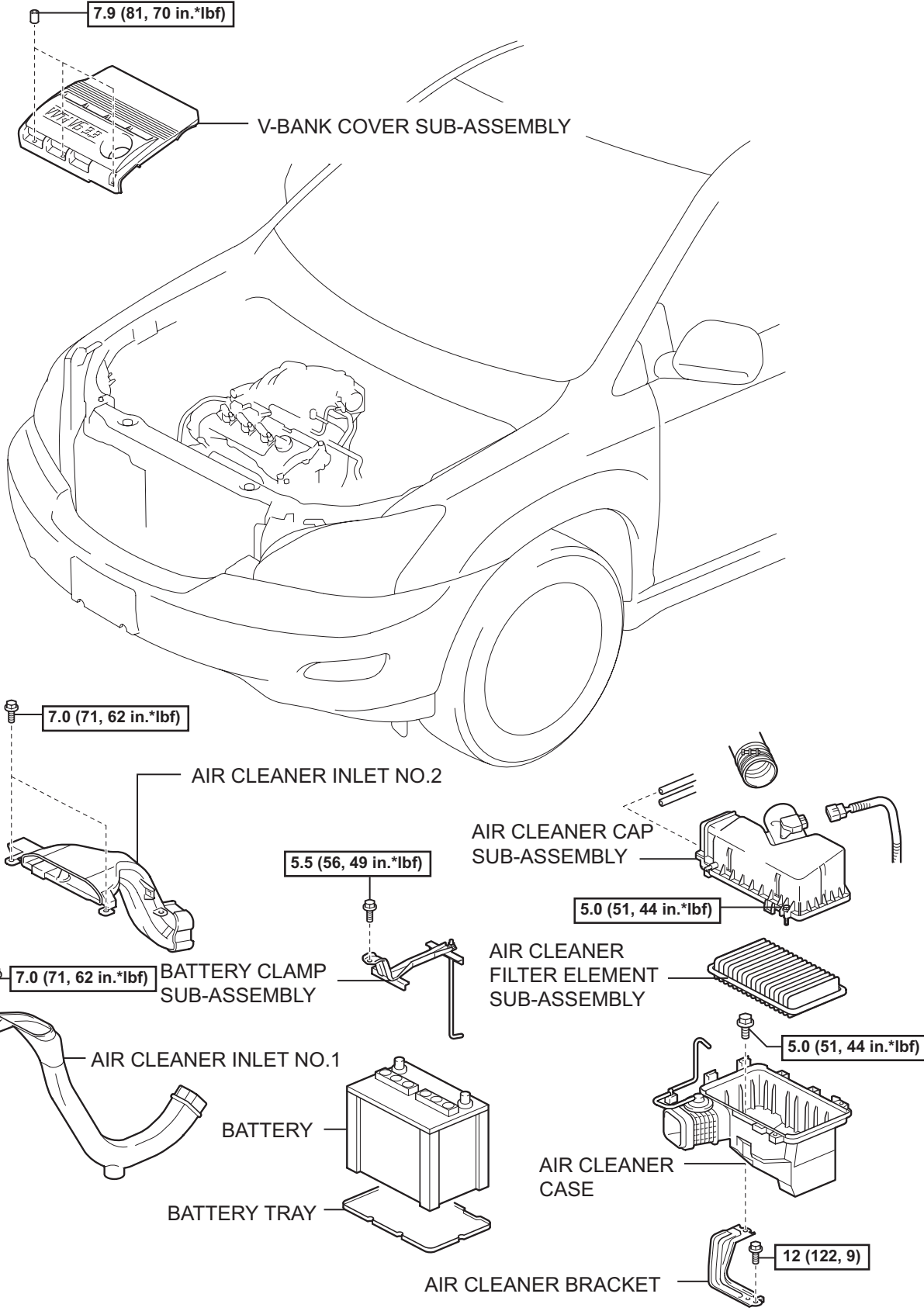

N*m (kgf*cm, ft.*lbf) : Specified torque

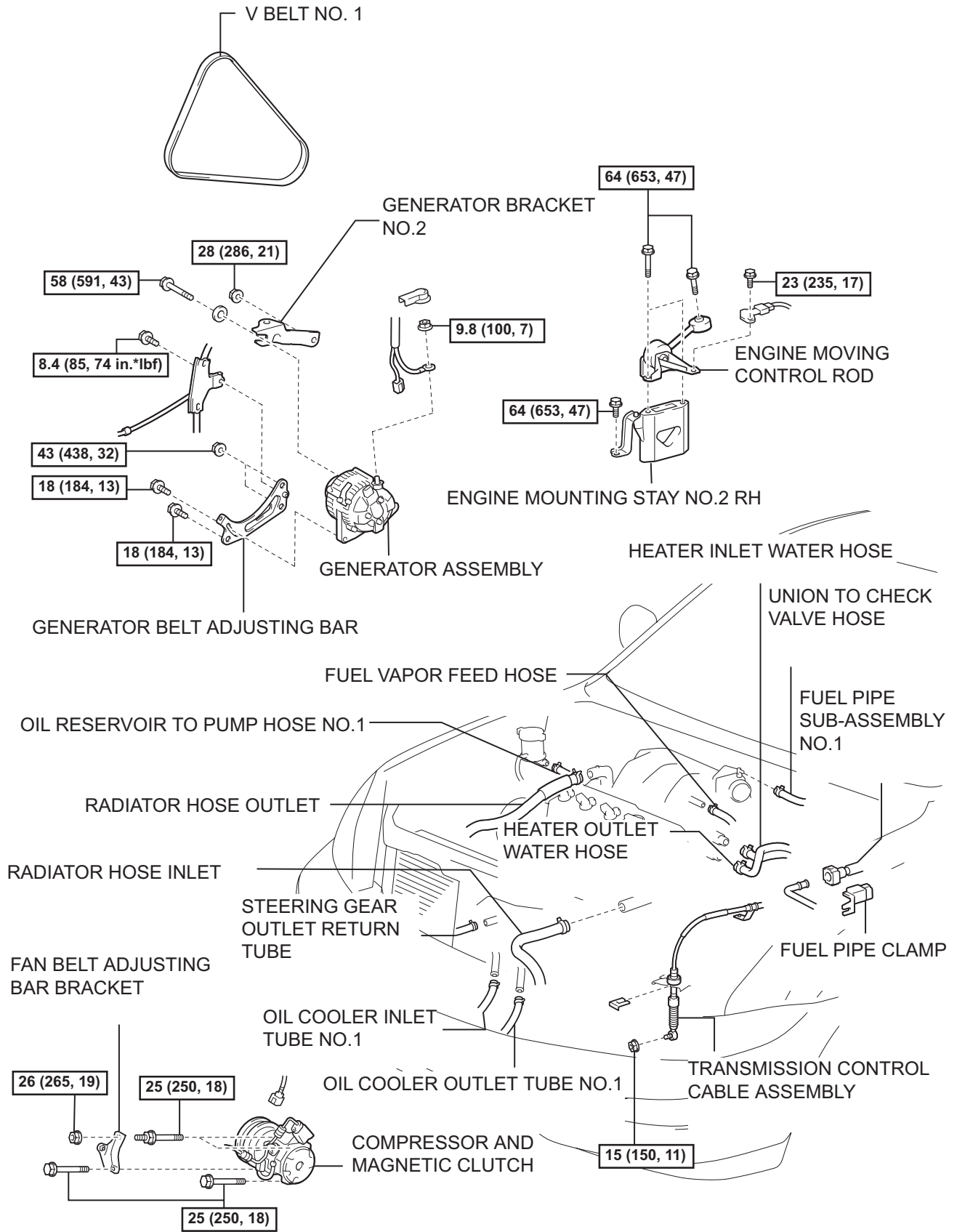

N*m (kgf*cm, ft.*lbf) : Specified torque

EM

W/ AIR SUSPENSION:

HEIGHT CONTROL SENSOR LINK SUB-ASSEMBLY FRONT

STEERING INTERMEDIATE SHAFT SUB-ASSEMBLY

FRONT STABILIZER LINK ASSEMBLY LH

FRONT SUSPENSION ARM SUB-ASSEMBLY LOWER NO.1 LH

EXHAUST PIPE SUB-ASSEMBLY FRONT NO.3

EXHAUST PIPE SUPPORT BRACKET NO.1

HEIGHT CONTROL SENSOR LINK SUB-ASSEMBLY FRONT

5.4 (55, 48 in.*lbf)

TIE ROD END SUB-ASSEMBLY LH

74 (755, 55)

49 (500, 36)

● COTTER PIN

● 294 (2,998, 217)

8.0 (82, 71 in.*lbf)

FRONT AXLE HUB LH NUT

SPEED SENSOR FRONT LH

127 (1,295, 94)

127 (1,295, 94)

74 (750, 54)

4WD: PROPELLER SHAFT

● GASKET

● GASKET

● 56 (571, 41)

● 56 (571, 41)

COMPRESSION SPRING

48 (490, 35)

EXHAUST PIPE ASSEMBLY FRONT

● 56 (571, 41)

N*m (kgf*cm, ft.*lbf) : Specified torque

● Non-reusable part

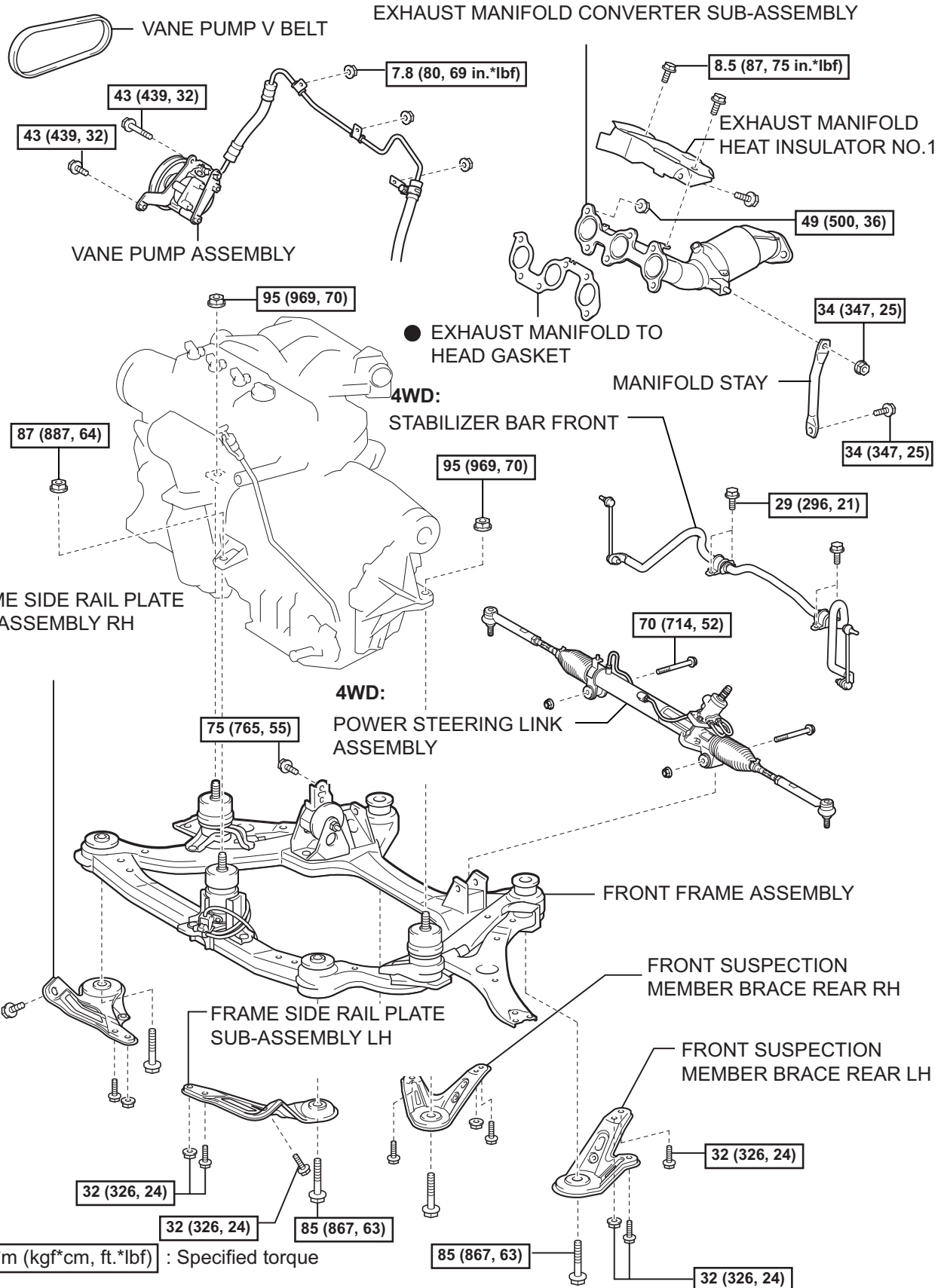

N*m (kgf*cm, ft.*lbf) : Specified torque

● Non-reusable part

EM

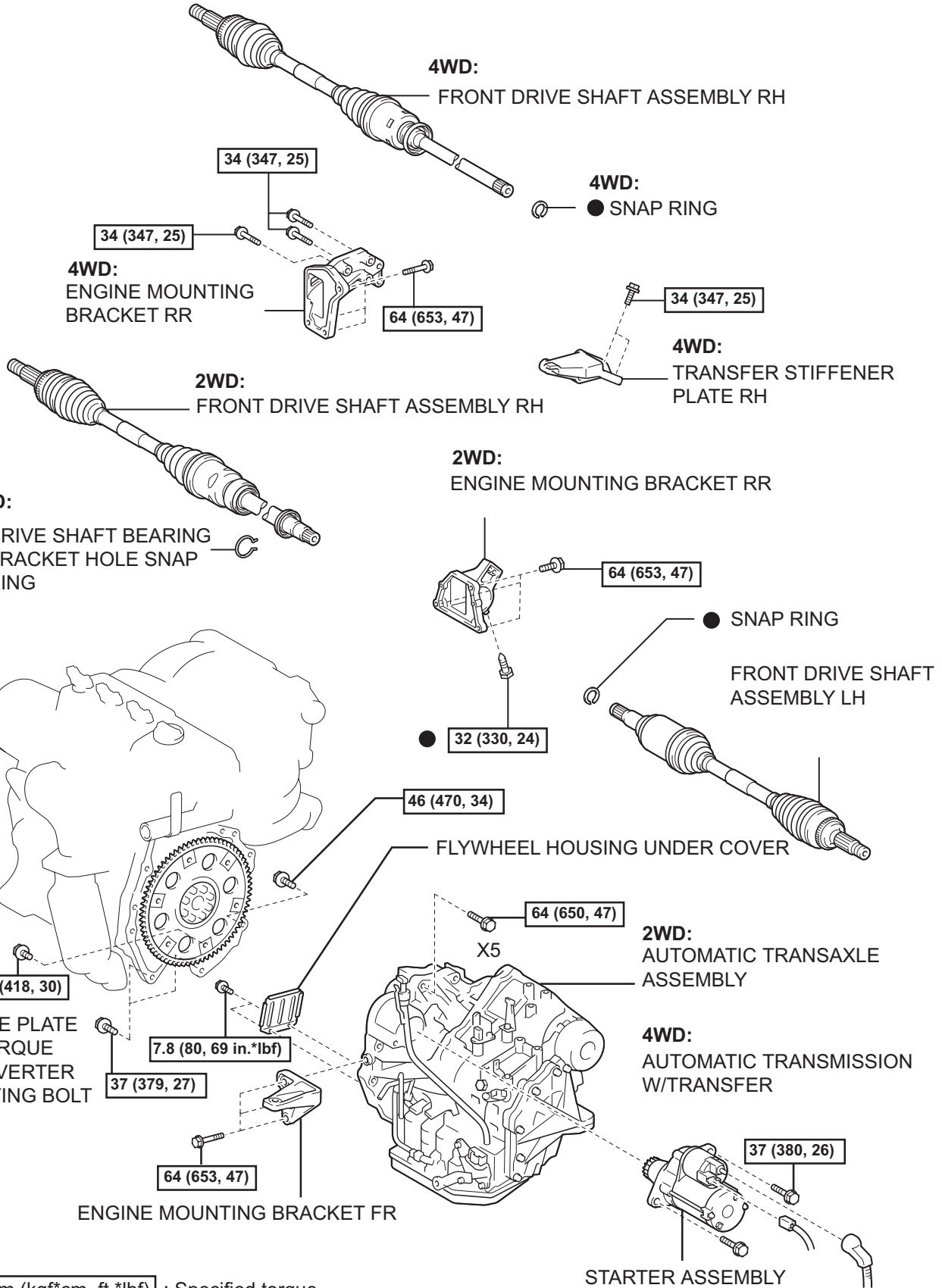

N*m (kgf*cm, ft.*lbf) : Specified torque

● Non-reusable part

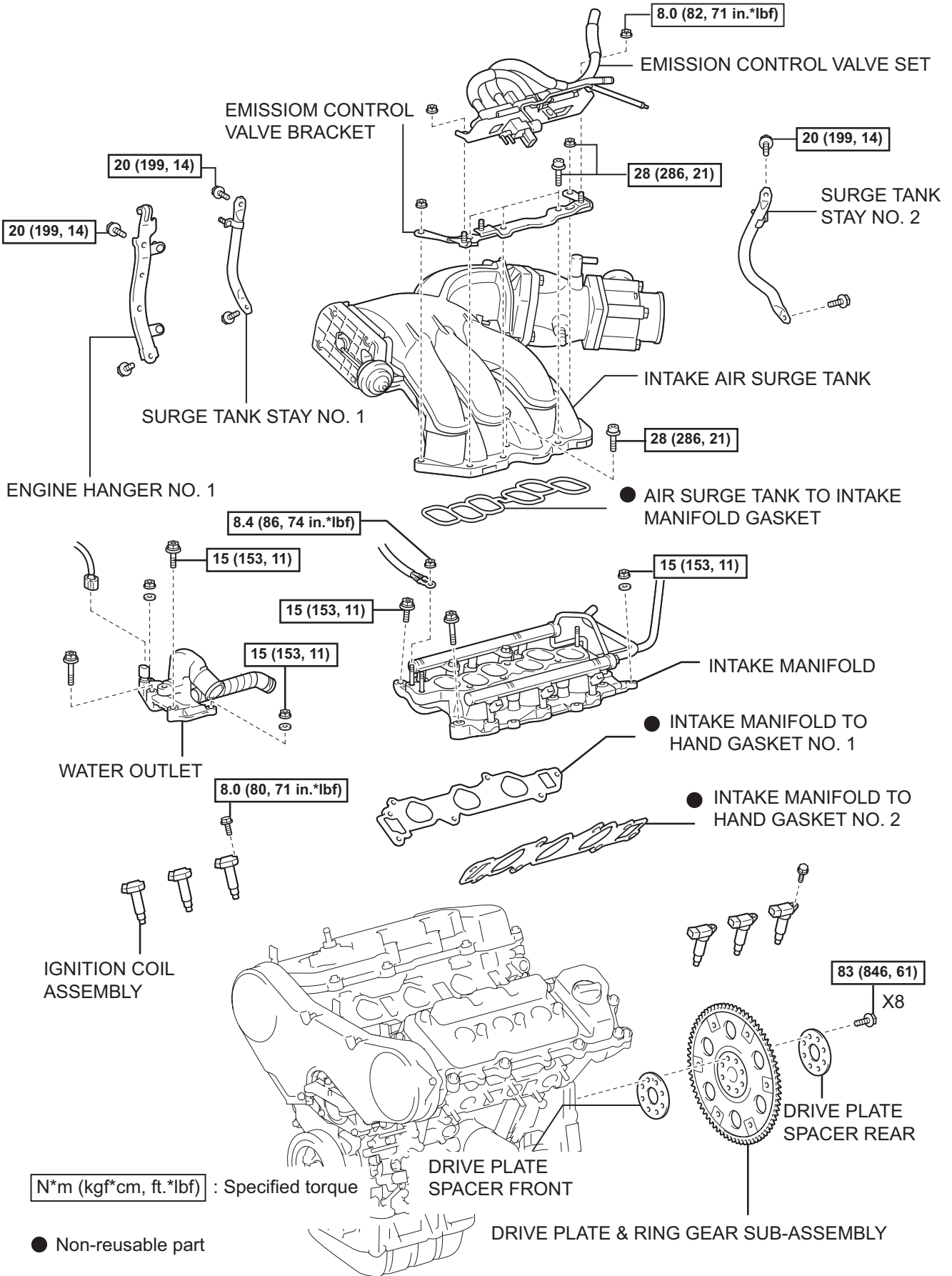

EM

TMMWV MADE:

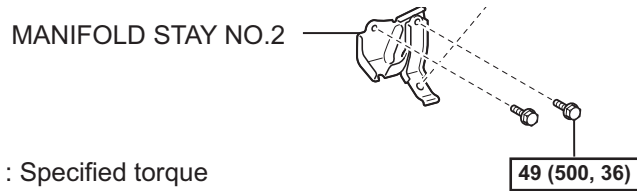
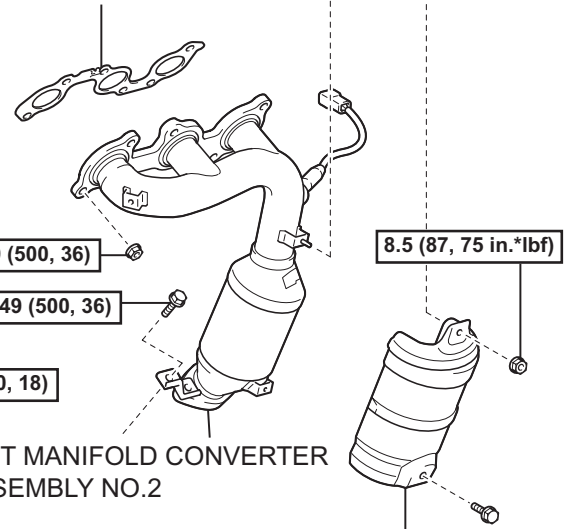
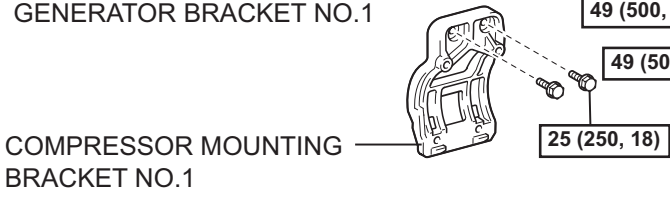
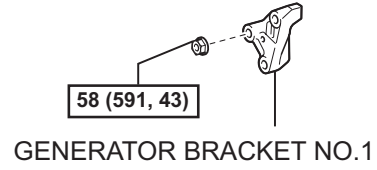
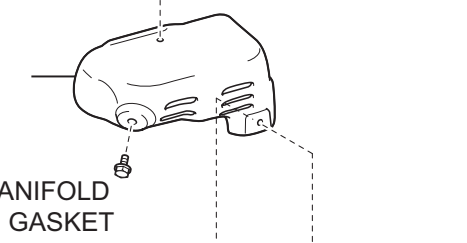
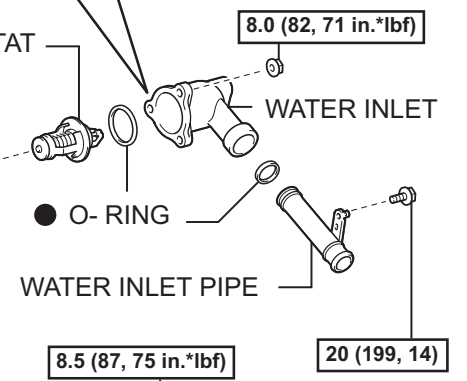
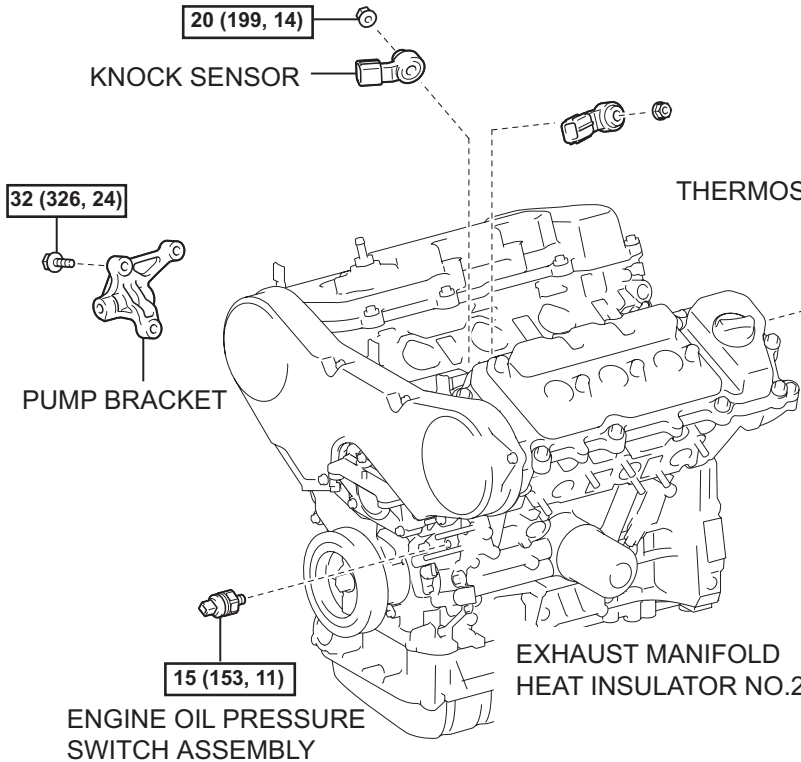

N*m (kgf*cm, ft.*lbf) : Specified torque

● Non-reusable part