

TIMING BELT COMPONENTS

EM

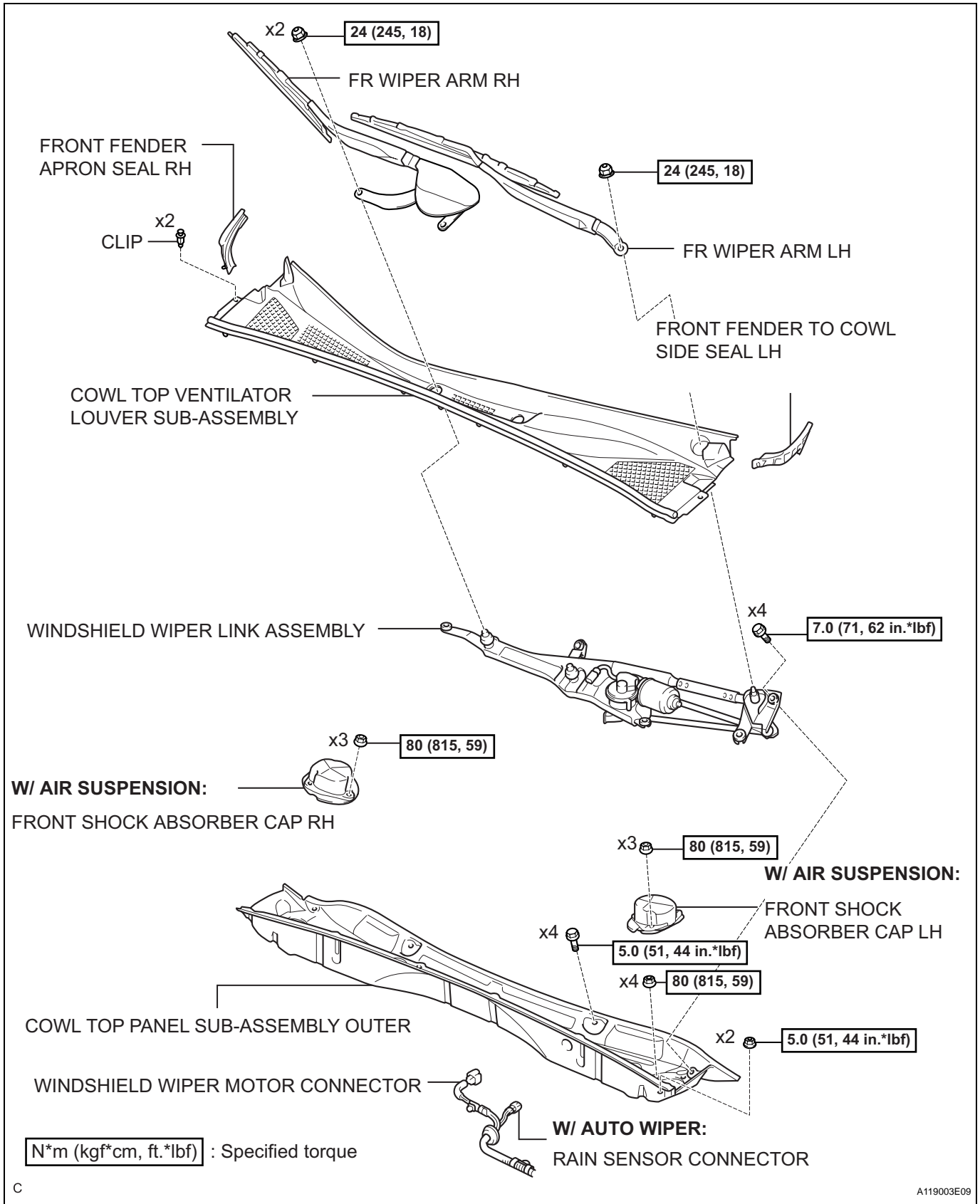

EM

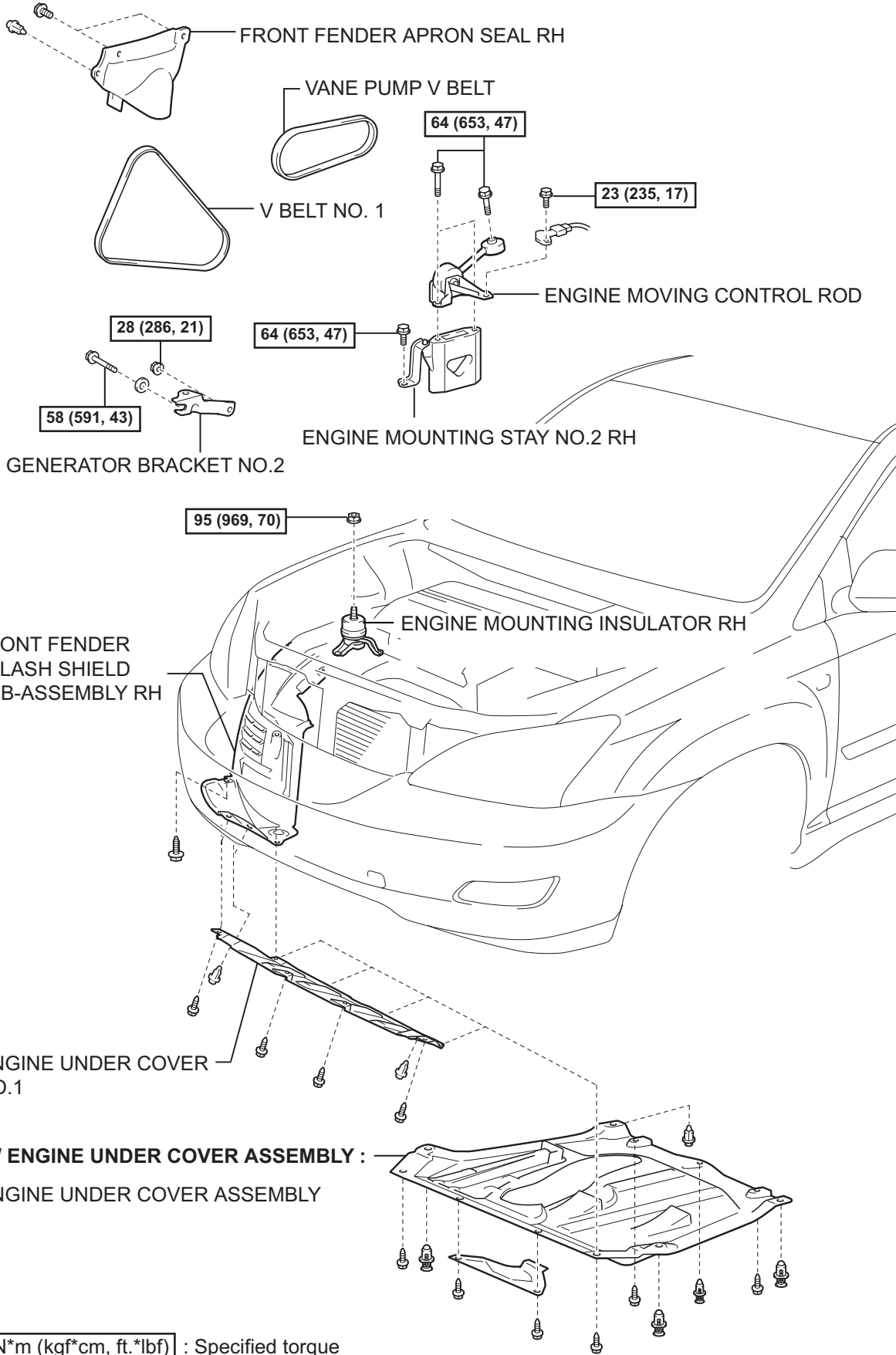

$N*m$ (kgf*cm, ft.*lbf) : Specified torque

