

N*m (kgf*cm, ft.*lbf) : Specified torque

EM

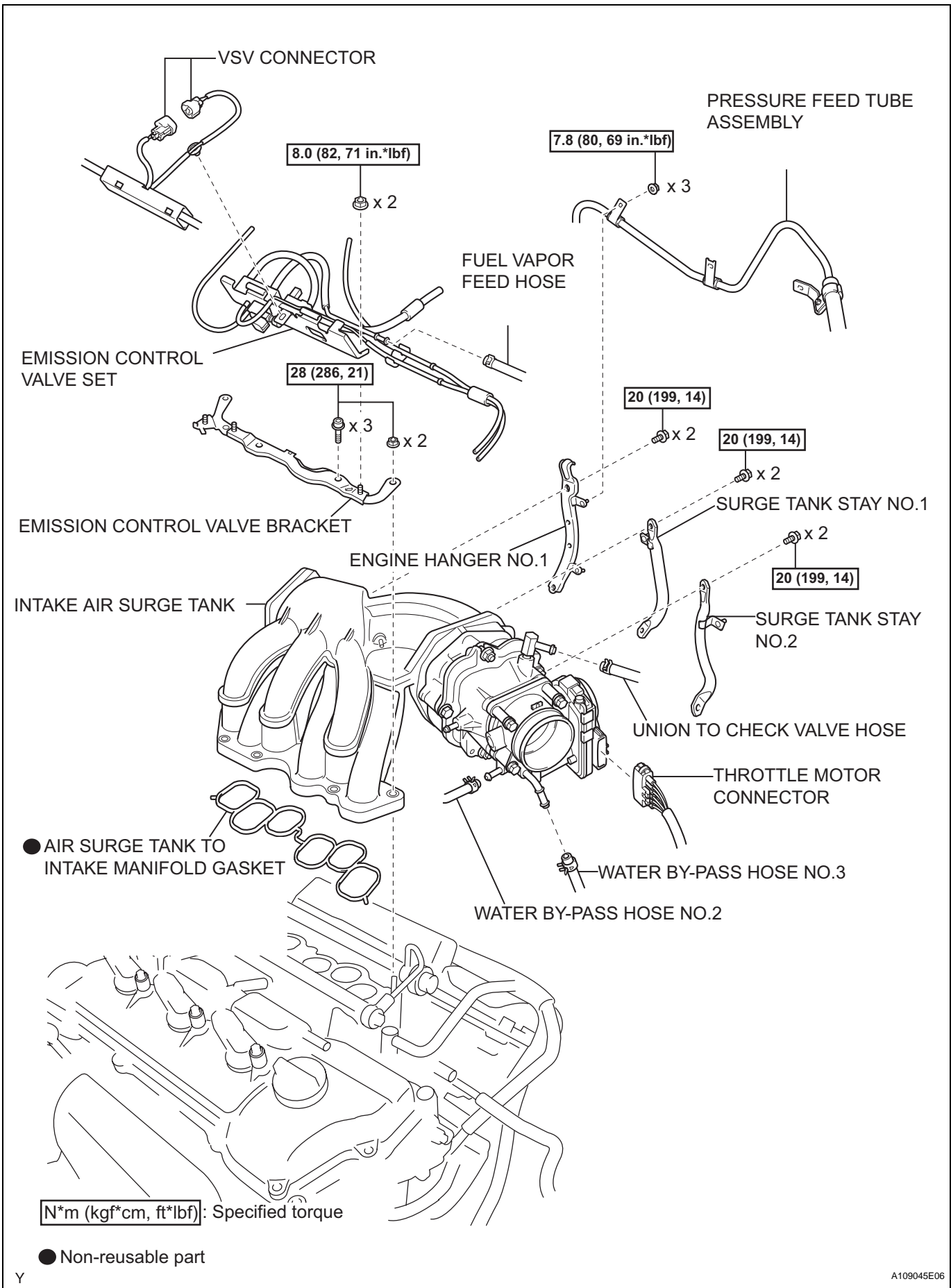

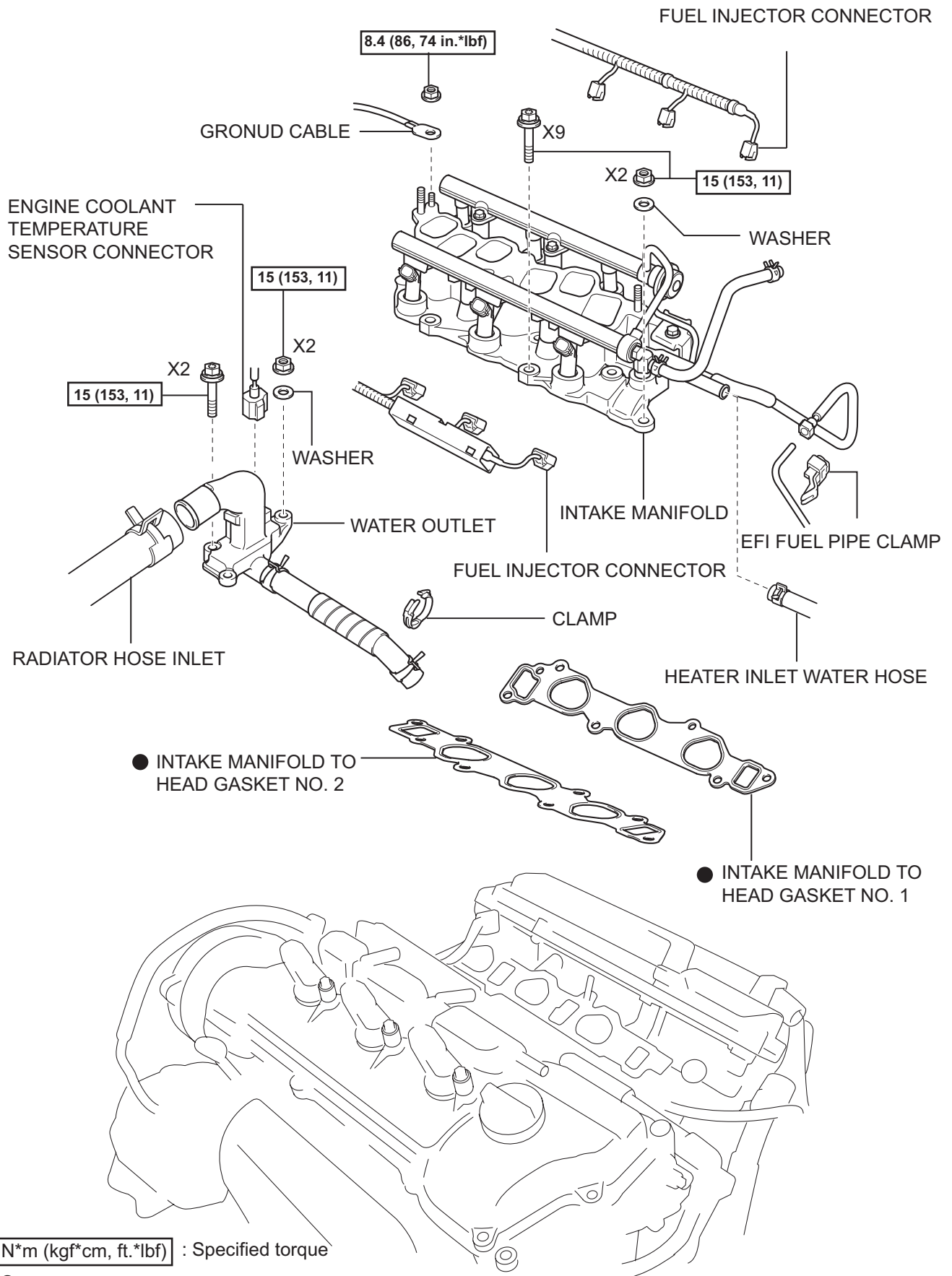

EM

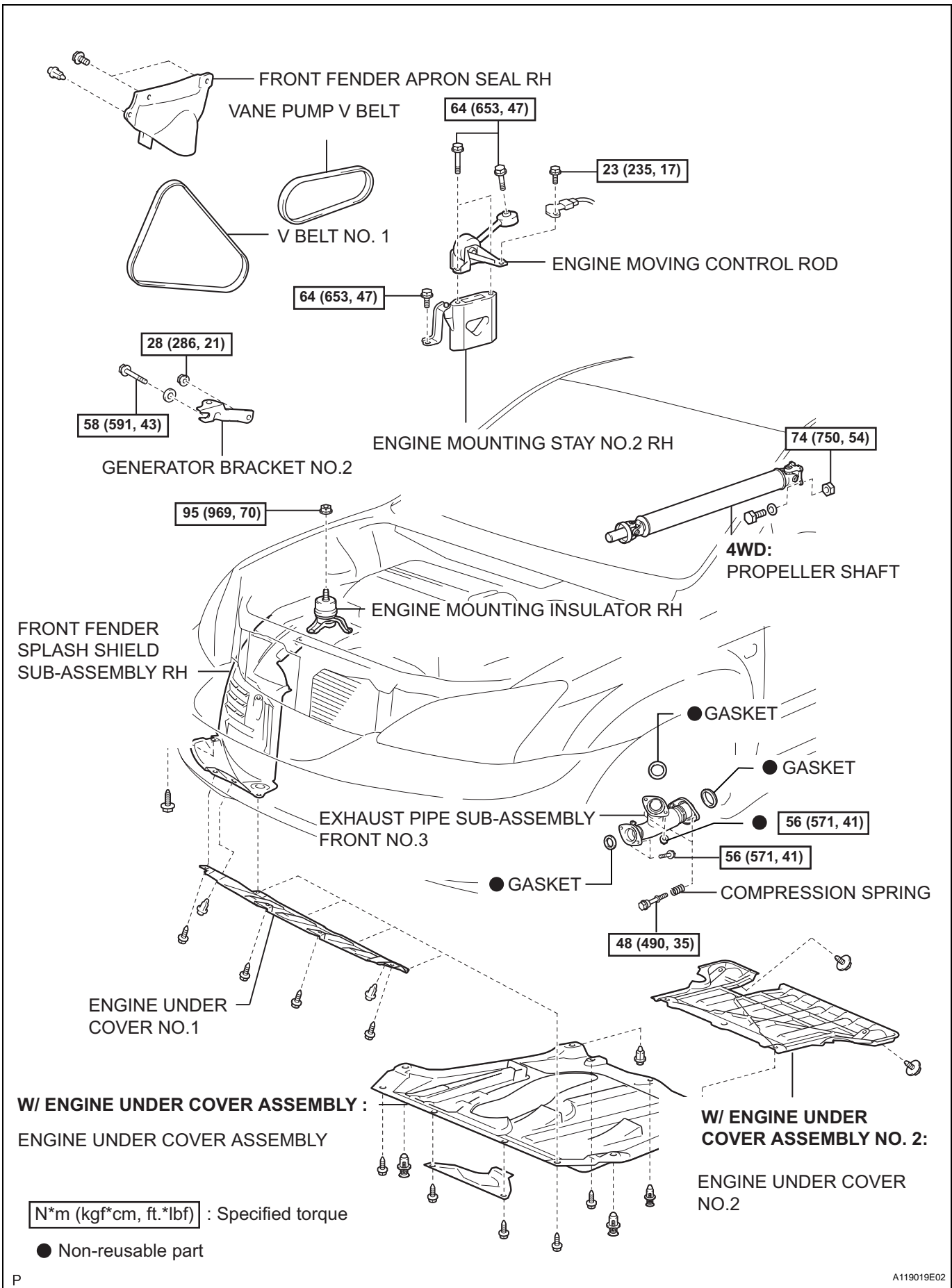

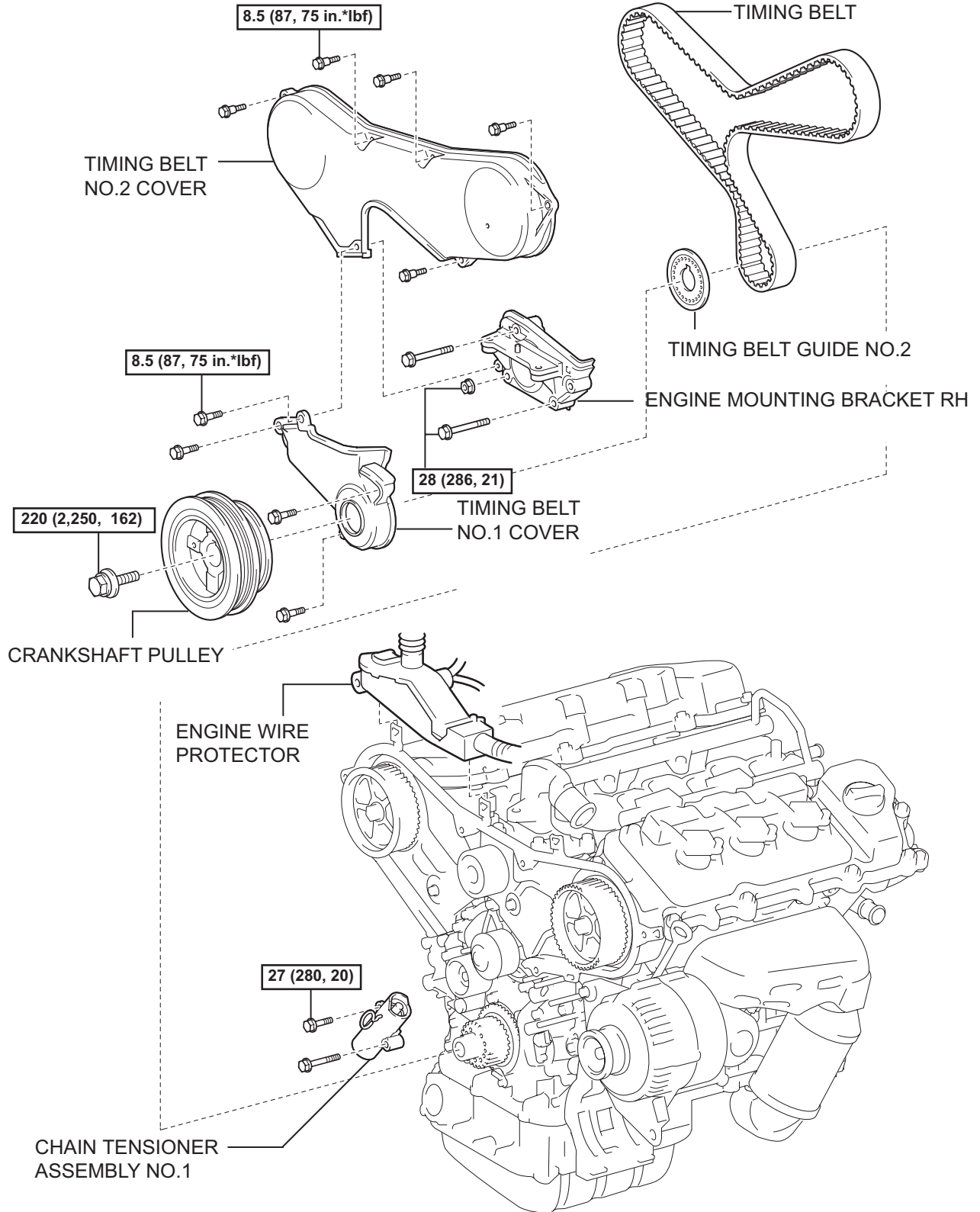

N*m (kgf*cm, ft.*lbf) : Specified torque

EM

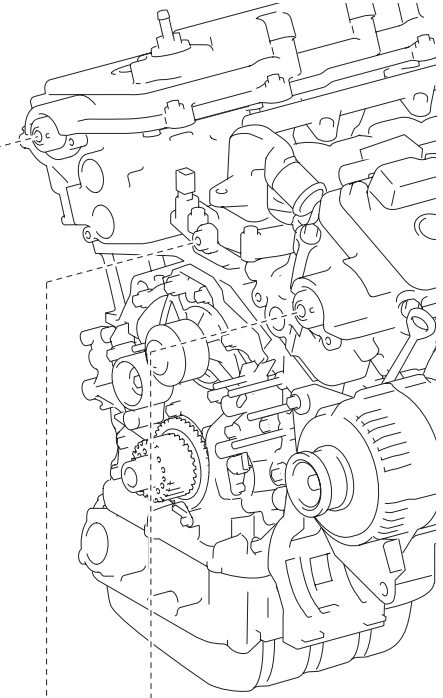

TIMING BELT NO.3 COVER

CAMSHAFT TIMING PULLEY

8.5 (87, 76 in.*lbf)

X6

125 (1,275, 92)

43 (438, 32)

TIMING BELT IDLER
SUB-ASSEMBLY NO.2

COLLAR
GASKET
BUSHING

ENGINE WIRE

N*m (kgf*cm, ft.*lbf) : Specified torque

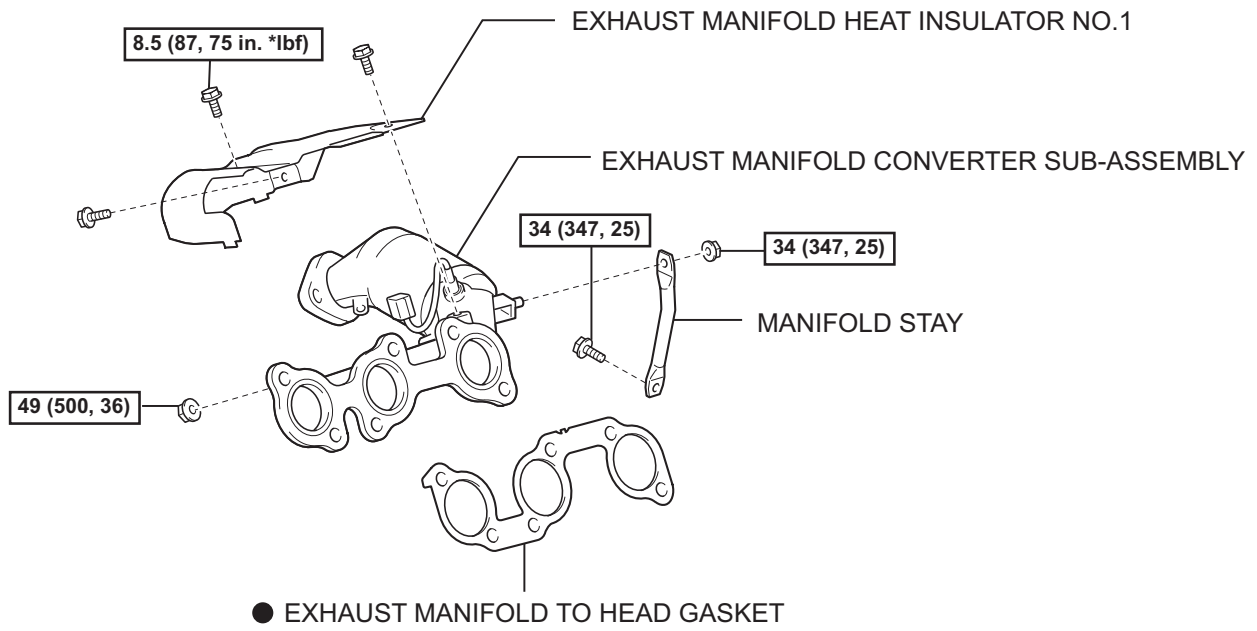

VANE PUMP ASSEMBLY

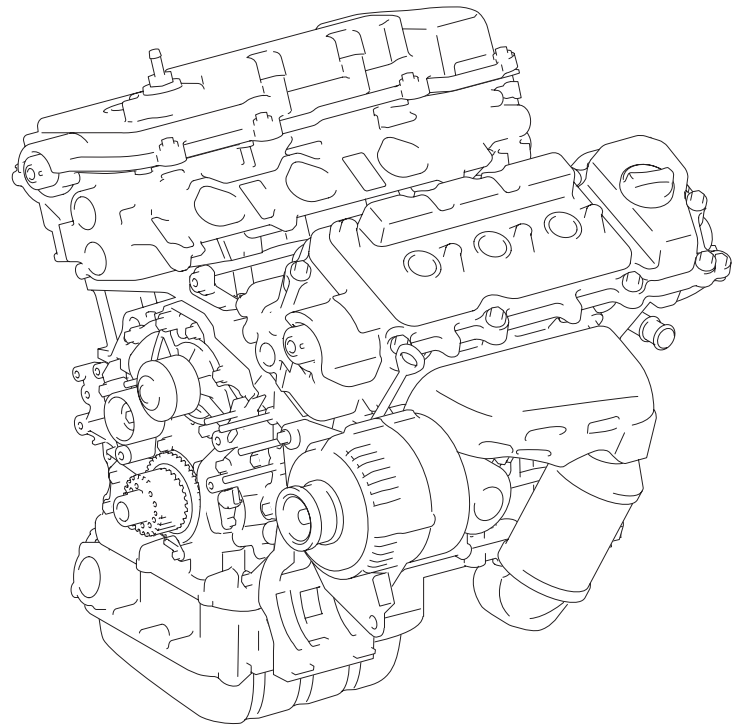
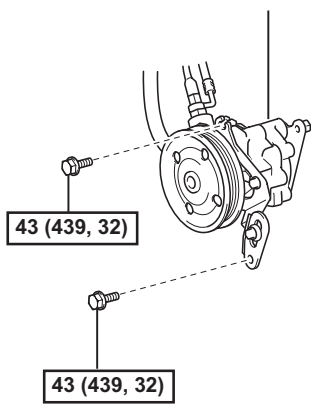

N*m (kgf*cm, ft.*lbf) : Specified torque

● Non-reusable part

EM

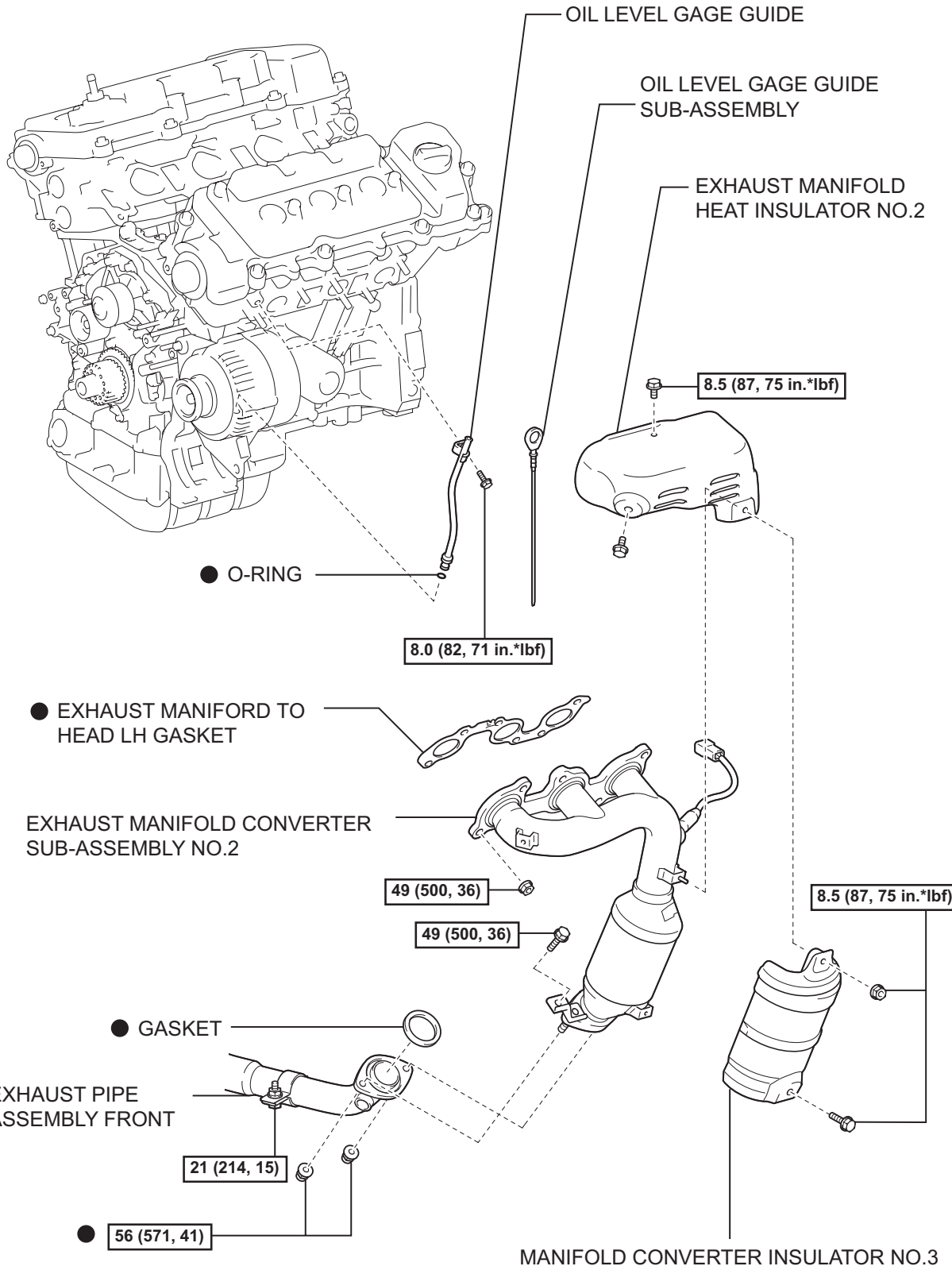

N*m (kgf*cm, ft.*lbf) : Specified torque

● Non-reusable part

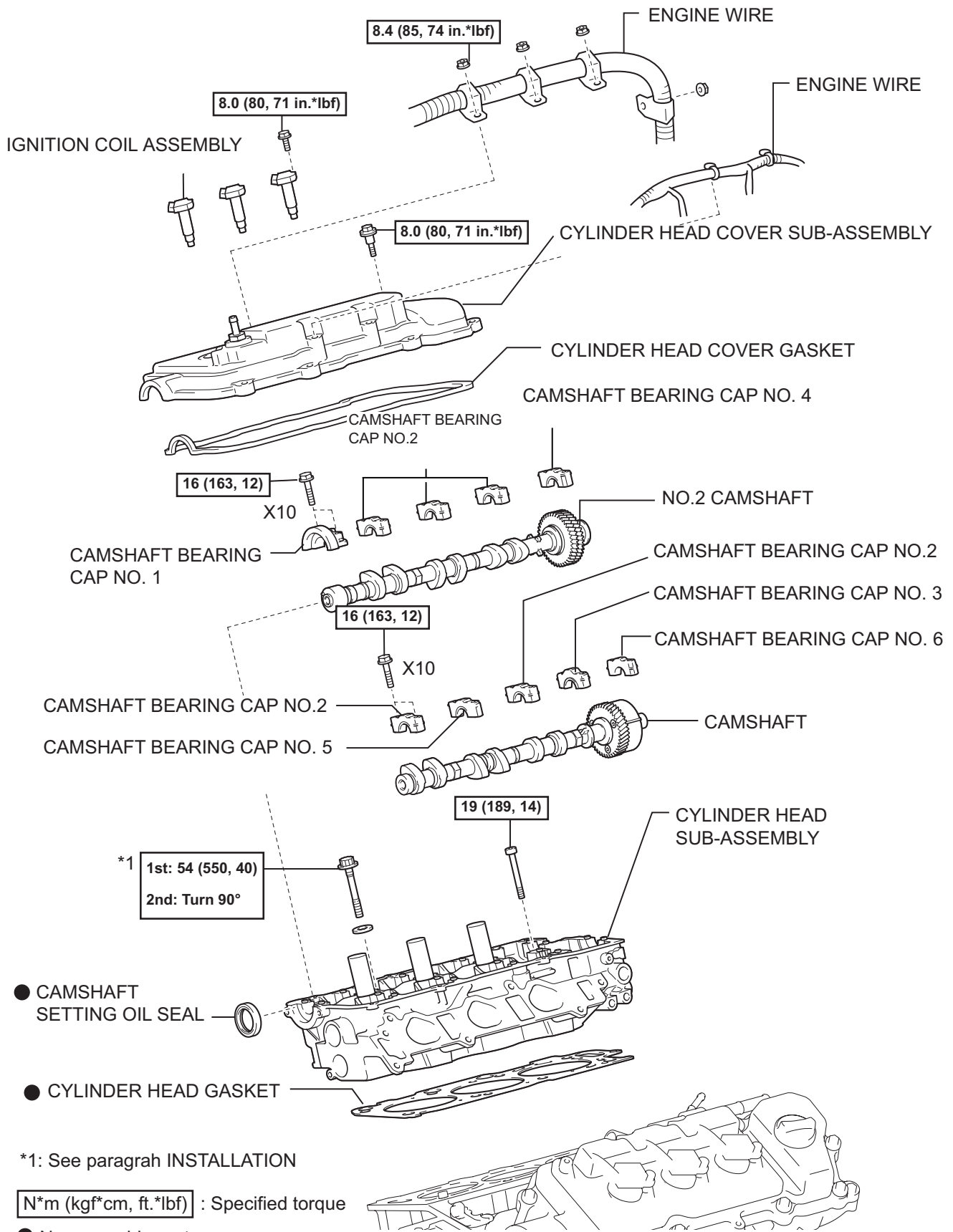

EM

