

# ENGINE FRONT OIL SEAL

## COMPONENTS

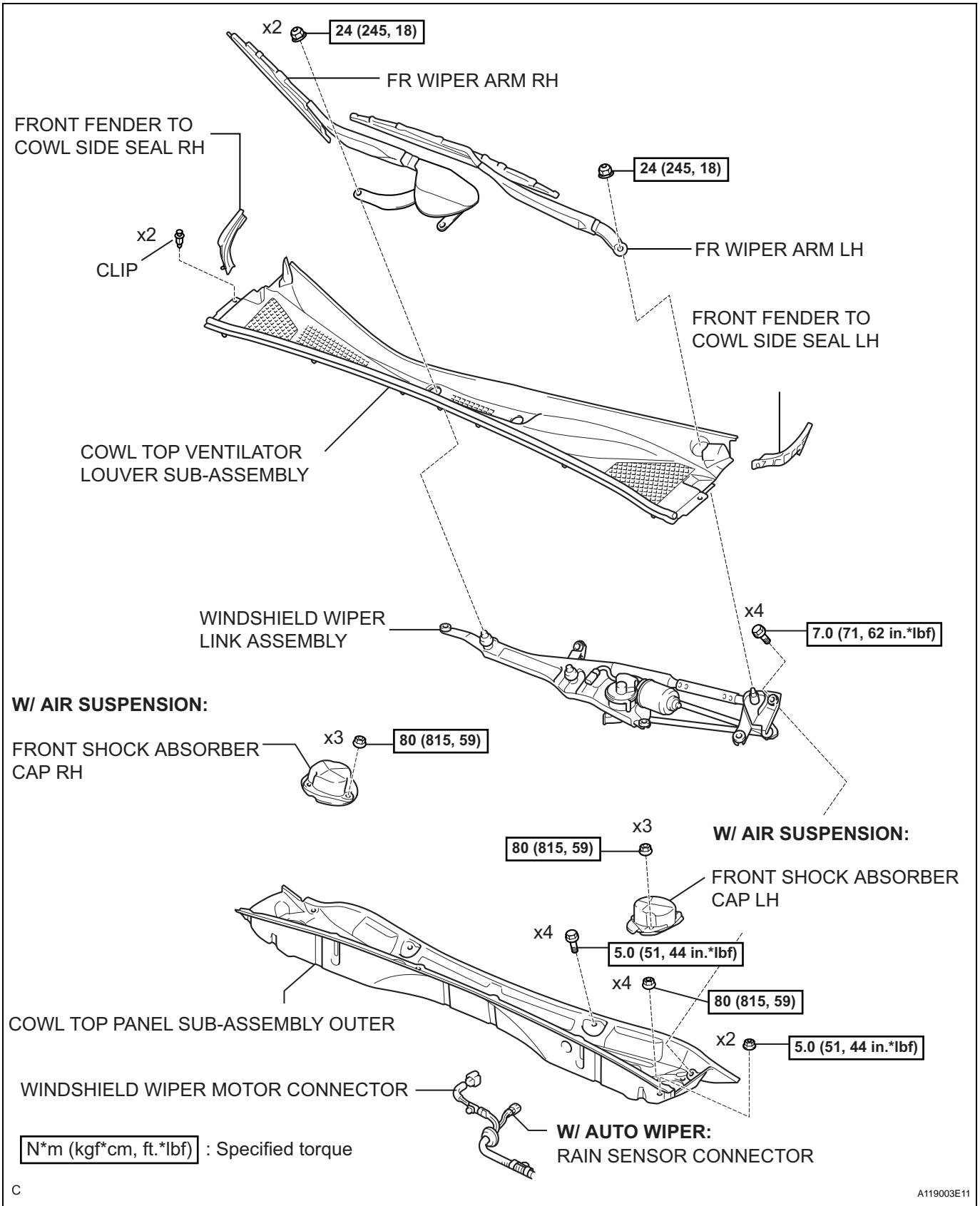

EM

EM

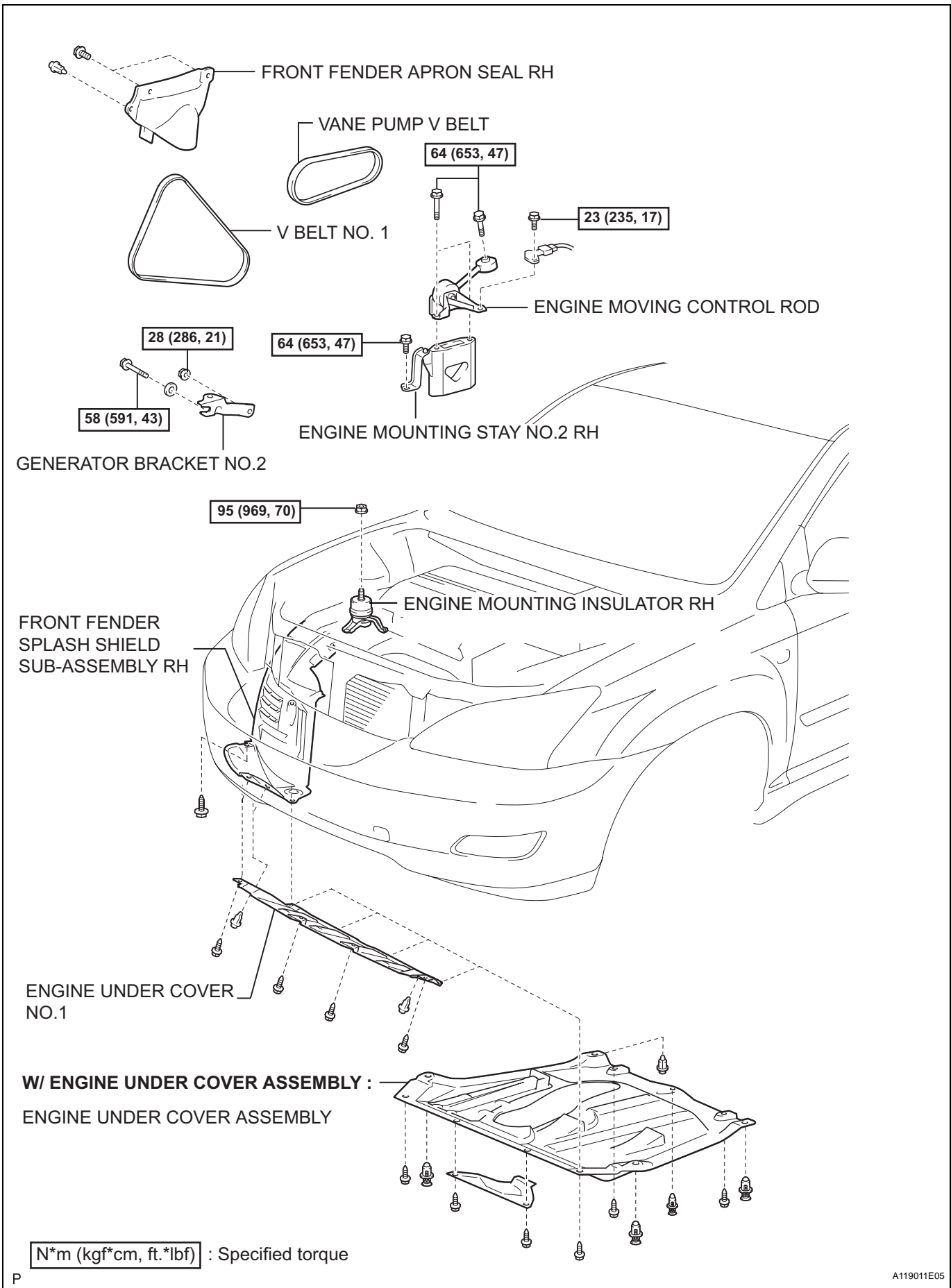

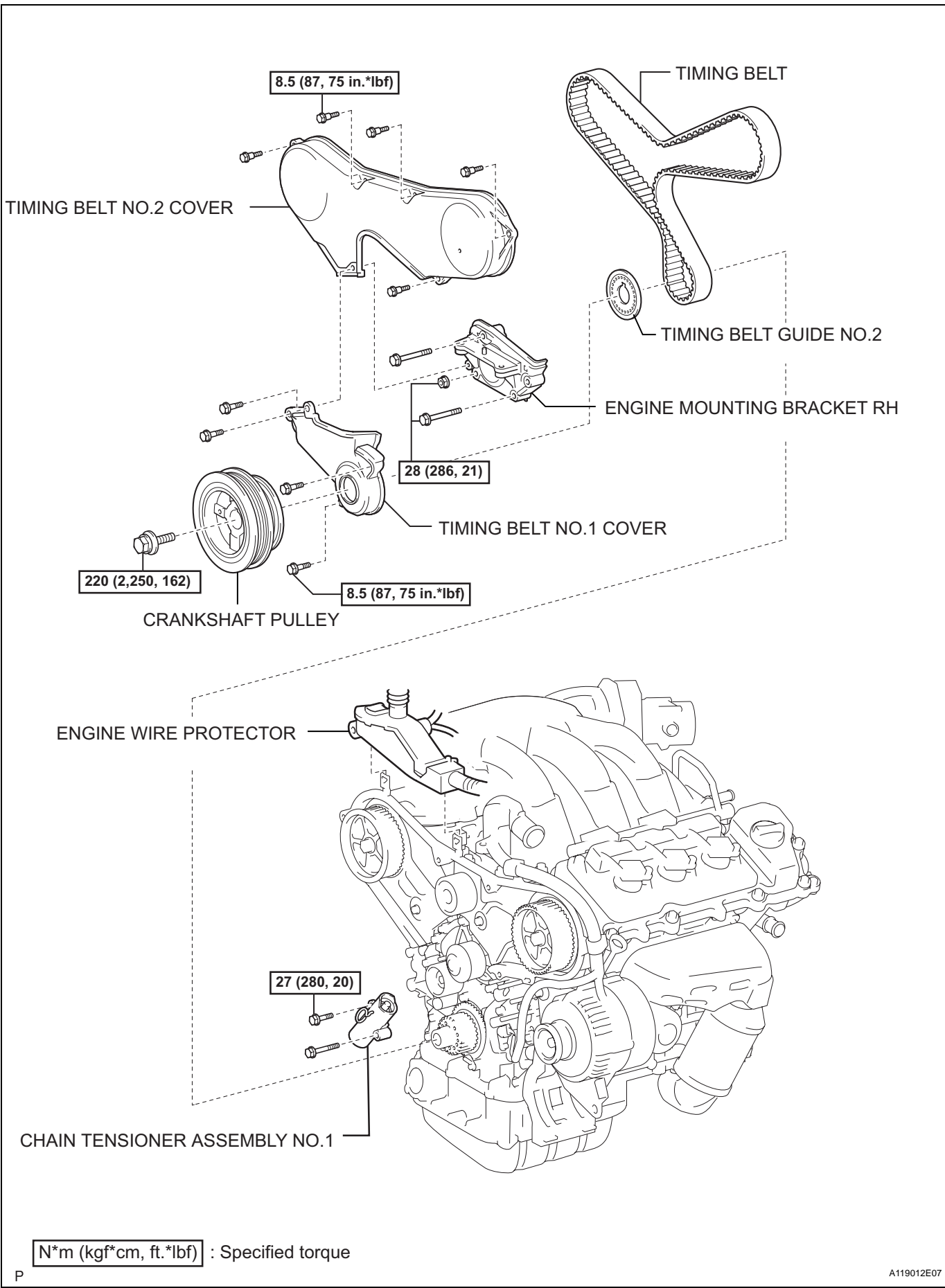

EM

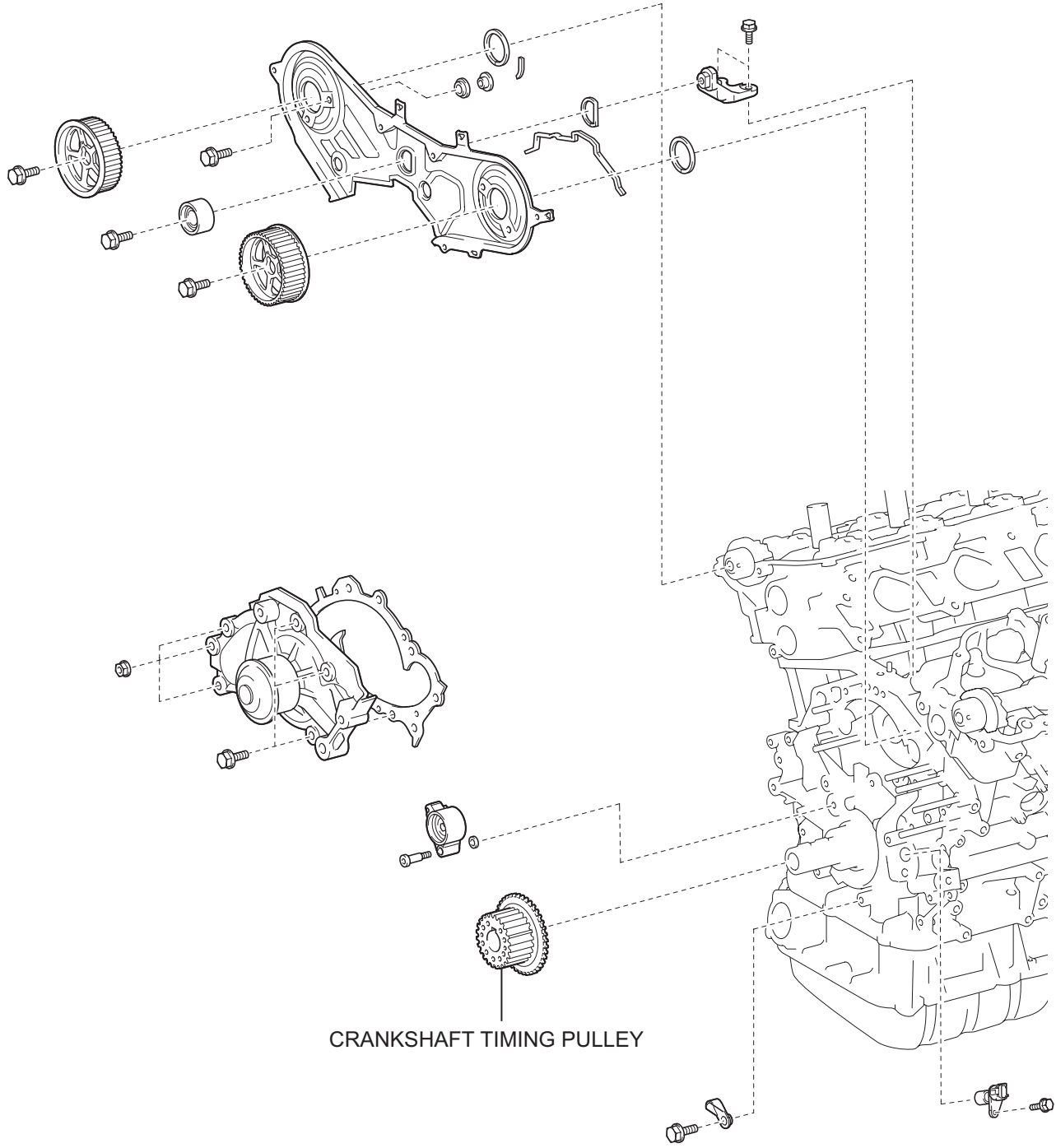

CRANKSHAFT TIMING PULLEY

● OIL PUMP SEAL

● Non-reusable part

