

INSTALLATION

1. INSTALL OUTSIDE MOULDING

- (a) Using a heat light, heat the moulding surface.

Heating temperature:

40 - 60°C (104 - 140°F)

NOTICE:

Do not heat the body excessively.

- (b) Remove the tape from the body.

- (c) Wipe off the stains with cleaner.

- (d) If reusing moulding:

Clean the moulding.

- (1) Using a heat light, heat the moulding.

Heating temperature:

20 - 30°C (68 - 86°F)

NOTICE:

Do not heat the moulding excessively.

- (2) Remove the tape from the moulding.

- (3) Wipe off the stains with cleaner.

- (4) Apply new double-sided tape to the moulding as shown in the illustration.

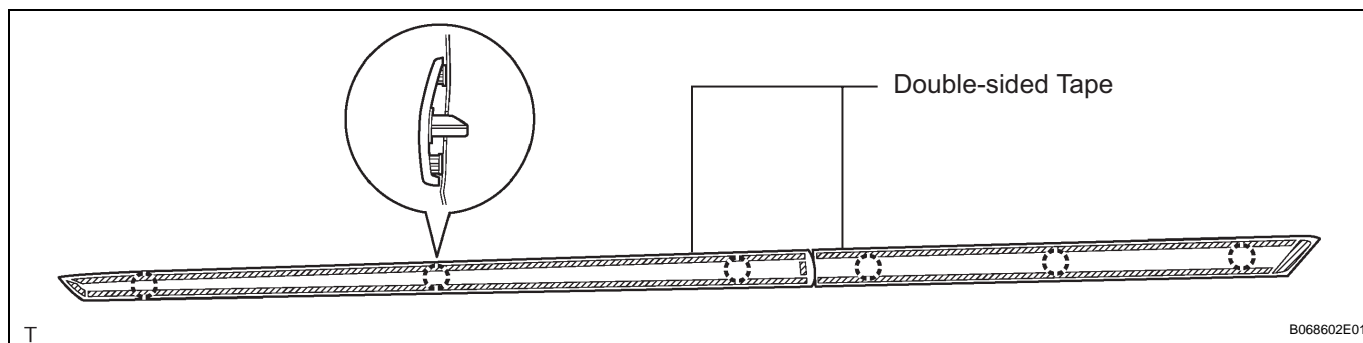

- (e) Match the reference pins on the moulding with the reference holes on the body.

- (f) Using a heat light, heat the body and moulding.

Heat temperature

Body	Moulding
40 - 60°C (104 - 140°F)	20 - 30°C (68 - 86°F)

NOTICE:

Do not heat the body and moulding excessively.

- (g) Remove the release paper from the moulding face.

NOTICE:

When the release paper is removed, take care that dirt or dust do not stick to the adhesive area.

(h) Attach the moulding securely to the body, as shown in the illustration.

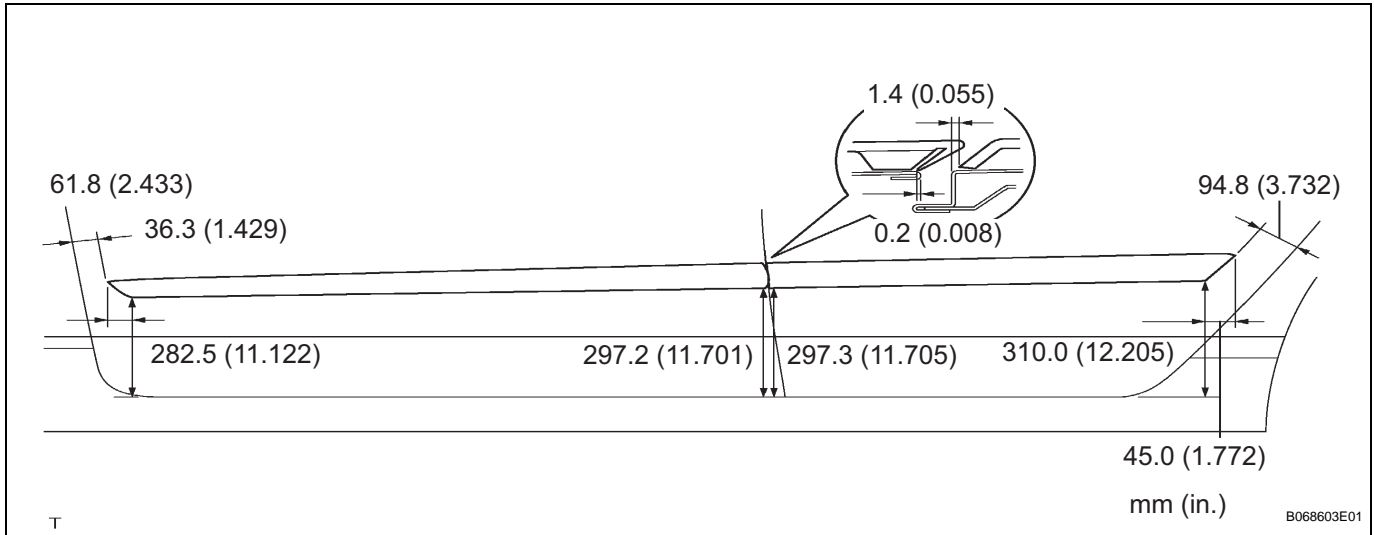

NOTICE:
 Do not apply excessive force onto the moulding,
 but apply steady pressure with your thumbs.