

# REAR DOOR WINDOW FRAME MOULDING

## COMPONENTS

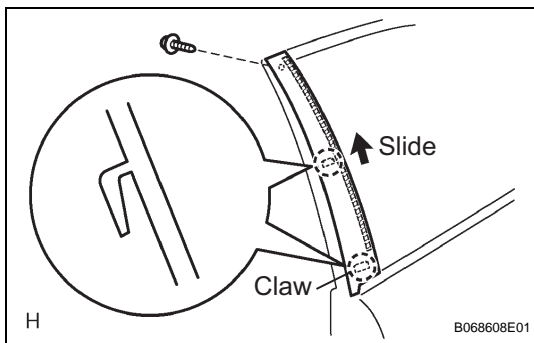
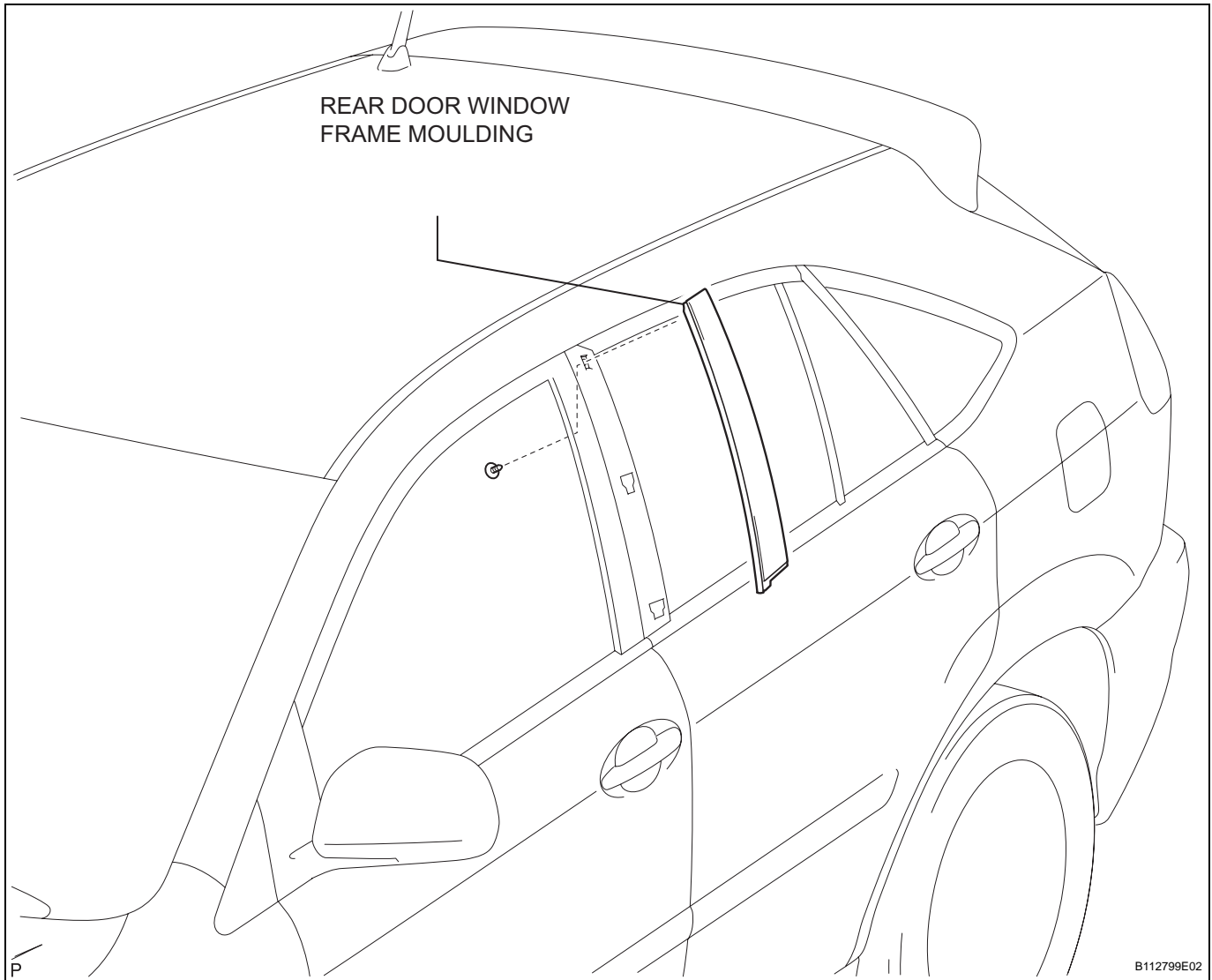

## REMOVAL

### 1. REMOVE REAR DOOR WINDOW FRAME MOULDING

- (a) Remove the screw.
- (b) Using a heat light, heat the moulding.

**Heating temperature:**

**40 - 60°C (104 - 140°F)**

**NOTICE:**

**Do not heat the moulding excessively.**

- (c) Slide the moulding upward to remove it.

**NOTICE:**

**If reusing the moulding, take care not to damage the moulding.**

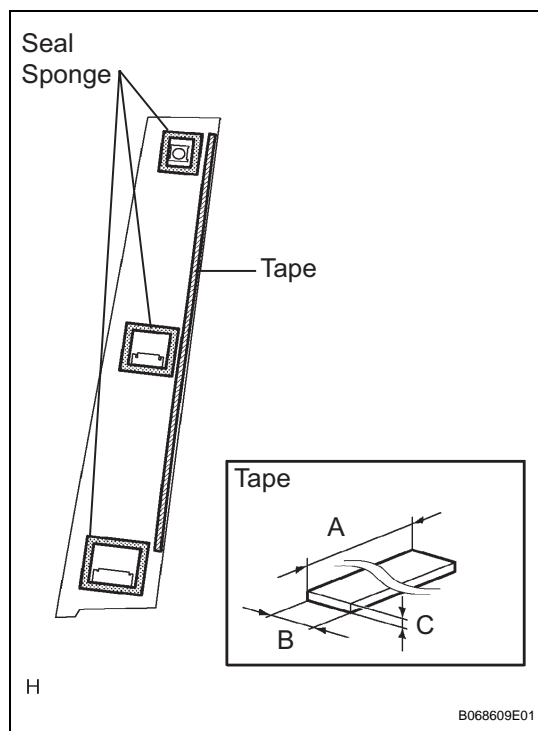

## INSTALLATION

### 1. INSTALL REAR DOOR WINDOW FRAME MOULDING

- Remove the tape from the moulding.
- Clean the contact surface of the body with white gasoline.
- Clean the outer circumference of the moulding with white gasoline.
- Apply new double-sided tape to the moulding, as shown in the illustration.

#### Dimension

A	B	C
400.0 mm (15.748 in.)	5.0 mm (0.197 in.)	1.2 mm (0.047 in.)

- Using a heat light, heat the body and moulding.

#### Heating temperature

Body	Moulding
40 - 60°C (104 - 140°F)	20 - 30°C (68 - 86°F)

#### NOTICE:

**Do not heat the body and moulding excessively.**

- Remove the release paper from the moulding face.

#### HINT:

Be careful that dirt or foreign objects do not stick to the adhesive part when removing the peeling paper.

- Engage the 2 claws and install the moulding with the screw.

#### NOTICE:

**Do not apply excessive force onto the moulding, but apply steady pressure with your thumbs.**