

FUEL INJECTOR

COMPONENTS

FU

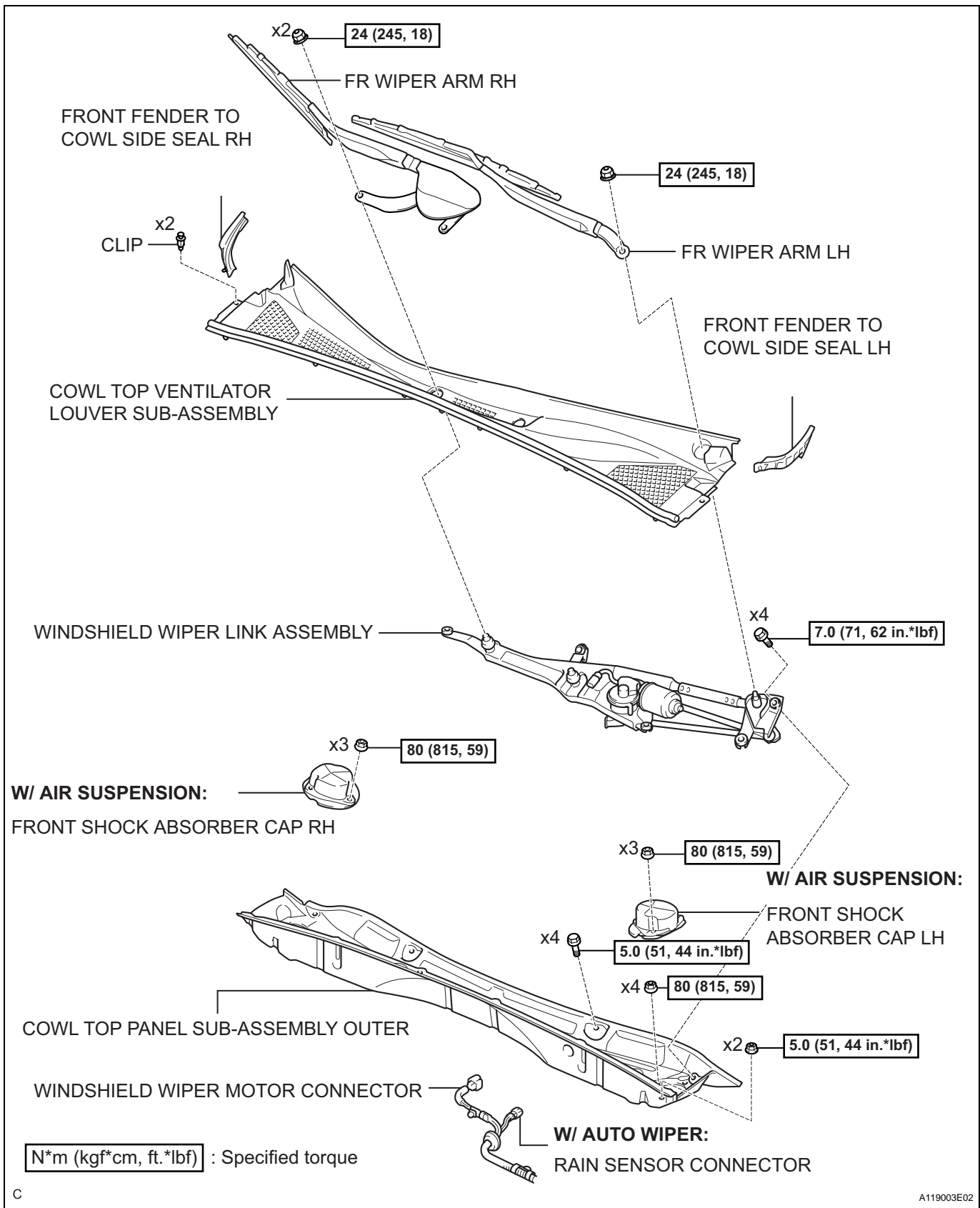

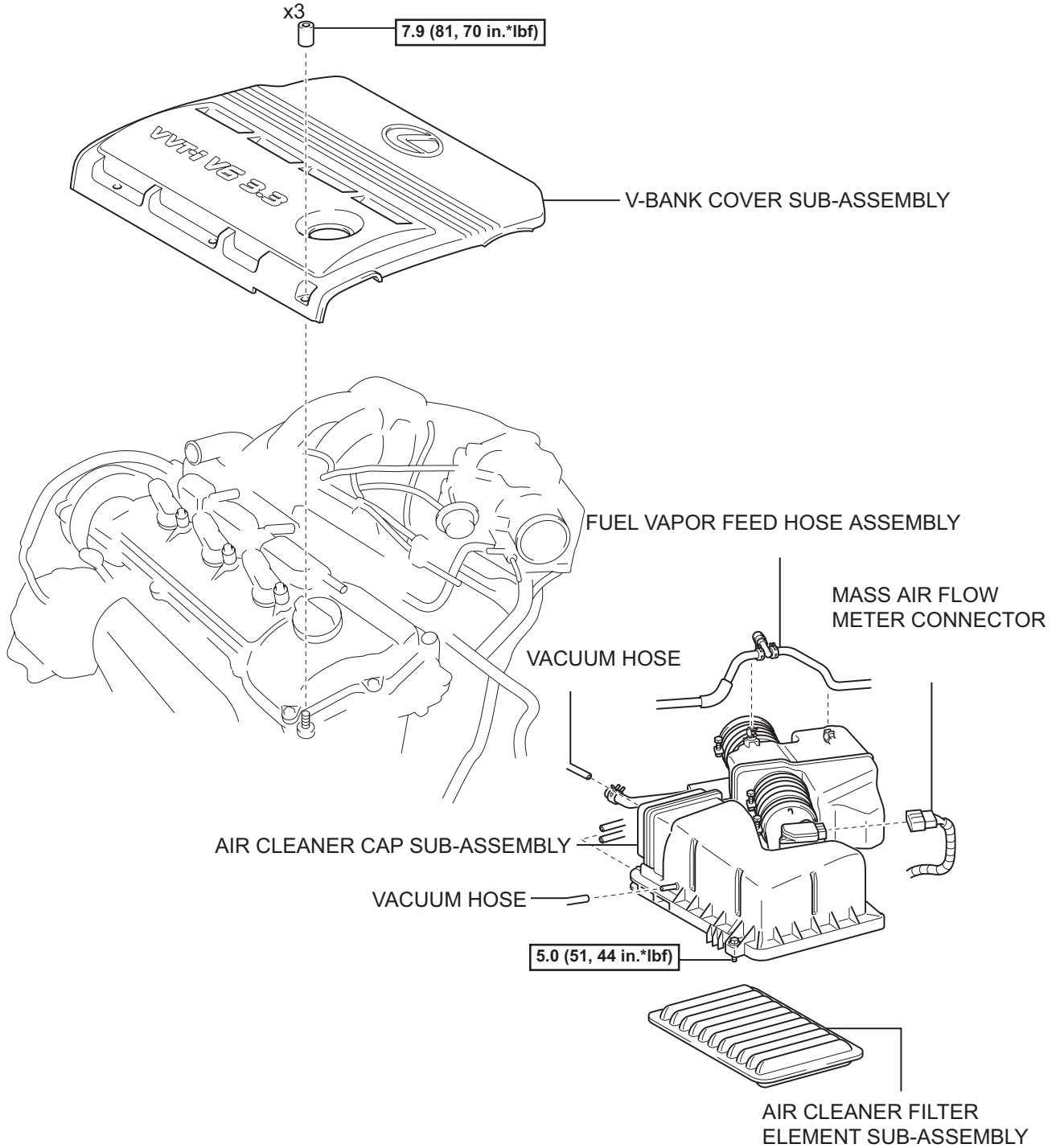

N*m (kgf*cm, ft.*lbf) : Specified torque

FU

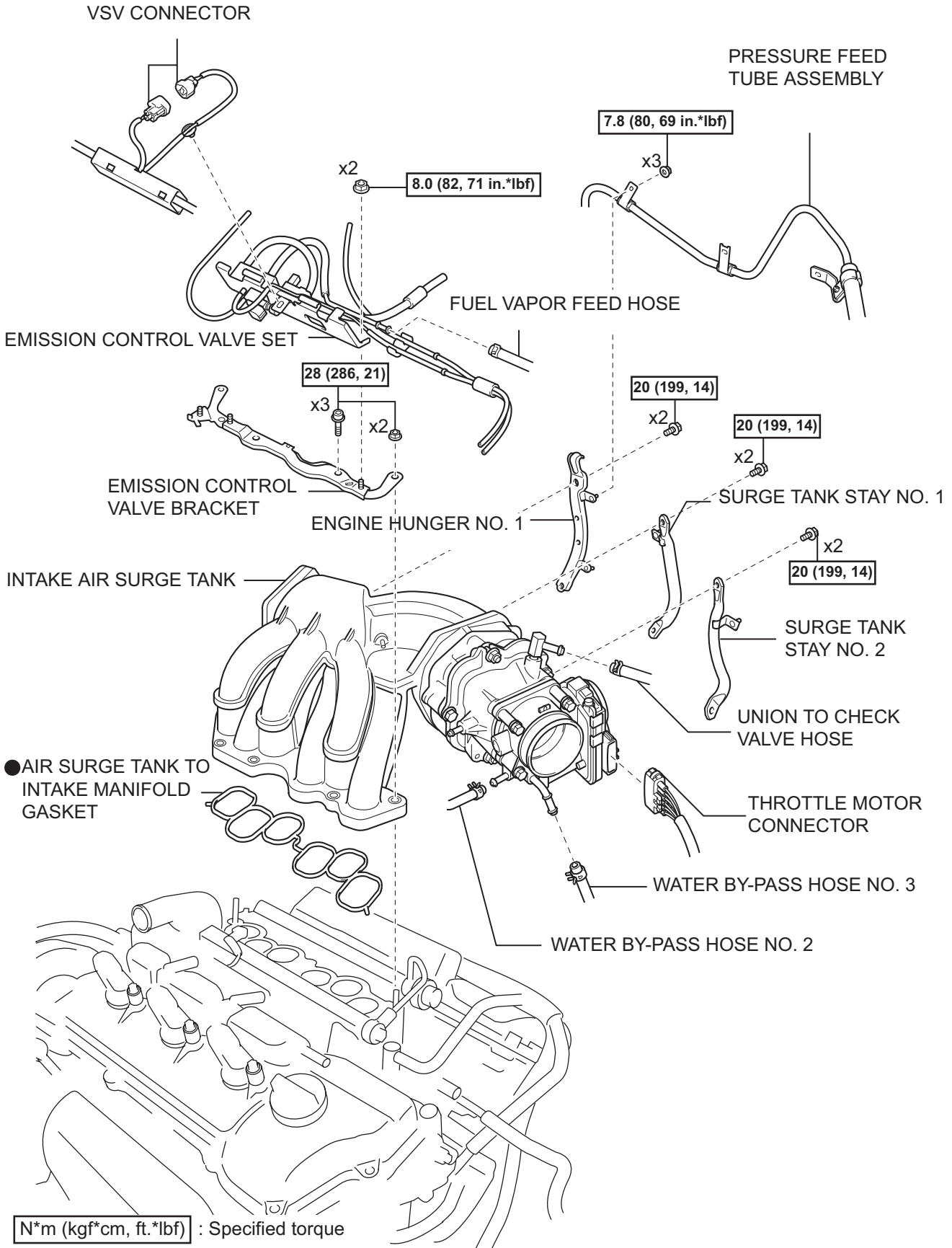

N*m (kgf*cm, ft.*lbf) : Specified torque

● Non-reusable part

Y

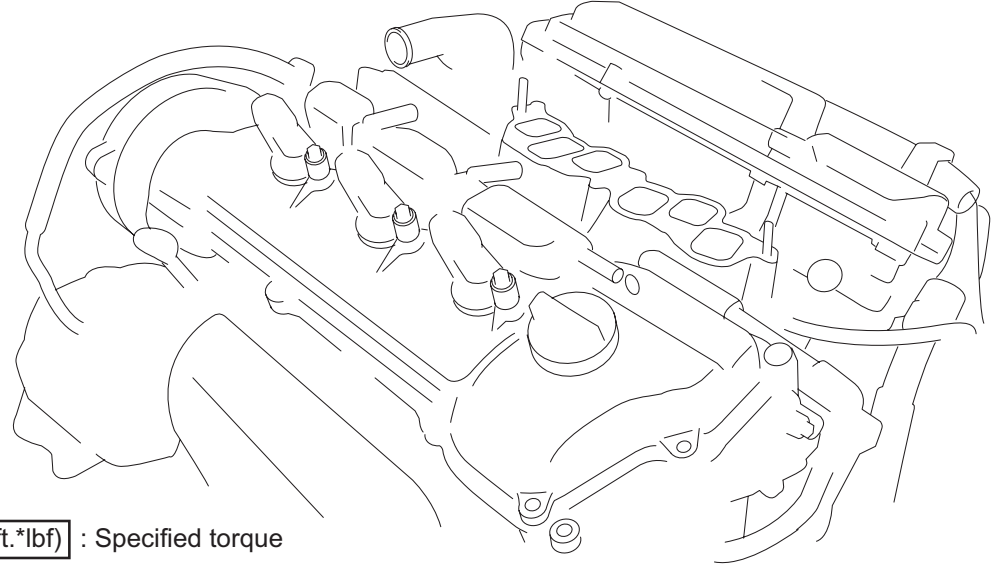
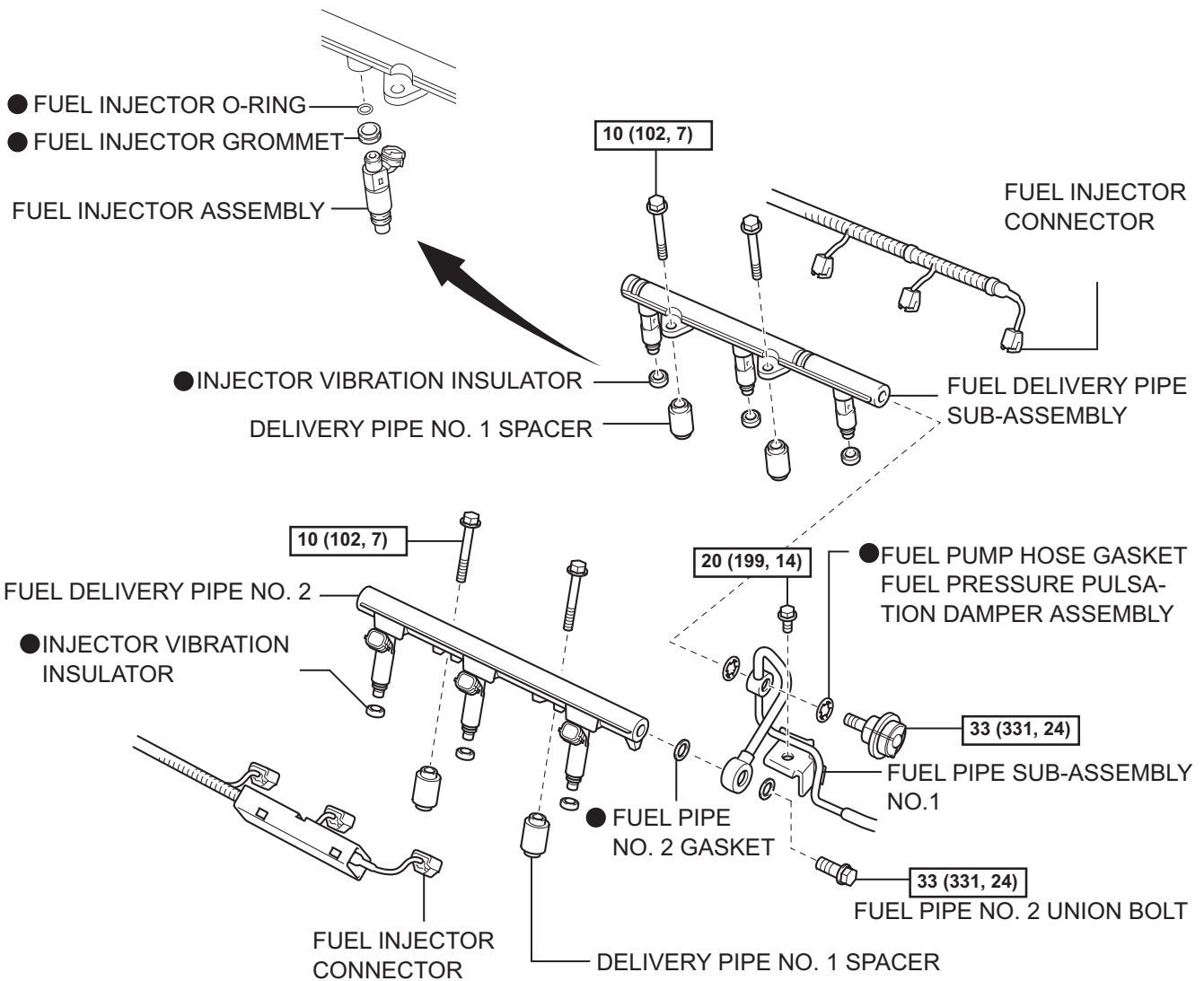

N*m (kgf*cm, ft.*lbf) : Specified torque

● Non-reusable part

Y